

IT  MANUALE OPERATIVO  
EN  OPERATIONS MANUAL

DE  BEDIENUNGSANLEITUNG

# COMAP InteliNano PLUS

Codice  
Code  
Code  
Codigo  
Kodezahl  
Código

MCM1K90F9003

- Unità controllo motore
- Engine control unit
- Protection moteur
- Motorschutz

- Unidad control motor
- Unidade de controlo do motor

Edizione  
Edition  
Édition  
Edición  
Ausgabe  
Edição

07.2019



MADE IN ITALY

**MOSA**



# MANUALE D'USO E MANUTENZIONE

ISTRUZIONI ORIGINALI - ITALIANO

# COMAP InteliNano PLUS

Codice  
Code  
Code  
Codigo  
Kodezahl  
Código

MCM1K90F9003

- Unità controllo motore
- Engine control unit
- Protection moteur
- Motorschutz

- Unidad control motor
- Unidade de controlo do motor

Edizione  
Edition  
Édition  
Edición  
Ausgabe  
Edição

07.2019





<b>1. INTERFACCIA OPERATORE .....</b>	<b>PAG. 6</b>
<b>2. AVVIAMENTO E ARRESTO DEL MOTORE .....</b>	<b>PAG. 7</b>
2.1 <i>MODALITÀ MANUALE (IN AMF).....</i>	PAG. 7
2.2 <i>MODALITÀ MANUALE (IN MRS).....</i>	PAG. 7
2.3 <i>MODALITÀ AUTO (IN AMF).....</i>	PAG. 7
2.4 <i>MODALITÀ AUTO (IN MRS).....</i>	PAG. 7
<b>3. STRUTTURA DELLE PAGINE.....</b>	<b>PAG. 8</b>
3.1 <i>STRUTTURA DELLE PAGINE PRINCIPALI (IN AMF) .....</i>	PAG. 8
3.2 <i>STRUTTURA DELLE PAGINE PRINCIPALI (IN MRS).....</i>	PAG. 8
<b>4. ALLARMI, EVENTI E GESTIONE DELLE REGISTRAZIONI .....</b>	<b>PAG. 9</b>
4.1 <i>EVENTI.....</i>	PAG.10
4.2 <i>AVVERTENZE.....</i>	PAG.11
4.2.1 <i>AVVERTIMENTO ATTIVO .....</i>	PAG.11
4.2.2 <i>AVVERTIMENTO NON ATTIVO .....</i>	PAG.11
4.2.3 <i>AVVERTIMENTI POSSIBILI .....</i>	PAG.11
4.3 <i>ALLARMI .....</i>	PAG.12
4.3.1 <i>PROCEDURA DI ARRESTO (SHUTDOWN).....</i>	PAG.12
4.3.2 <i>ALLARME (SHUTDOWN) ATTIVO NON CONFERMATO .....</i>	PAG.12
4.3.3 <i>ALLARME (SHUTDOWN) ATTIVO CONFERMATO .....</i>	PAG.12
4.3.4 <i>ALLARME (SHUTDOWN) NON ATTIVO NON CONFERMATO .....</i>	PAG.12
4.3.5 <i>ALLARME (SHUTDOWN) NON ATTIVO CONFERMATO .....</i>	PAG.12
4.3.6 <i>ALLARMI (SHUTDOWN) POSSIBILI.....</i>	PAG.13
4.4 <i>MESSAGGI ECU .....</i>	PAG.14
<b>5 IMPOSTAZIONE .....</b>	<b>PAG.14</b>
5.1 <i>ACCESSO ALLA MODALITÀ DI IMPOSTAZIONE.....</i>	PAG.14
5.2 <i>SETPPOINTS.....</i>	PAG.14
<b>6 DATI TECNICI .....</b>	<b>PAG.17</b>
<b>7 PROCEDURA RESET ALLARME ORE/MANUTENZIONE .....</b>	<b>PAG.18</b>

## 1. INTERFACCIA OPERATORE

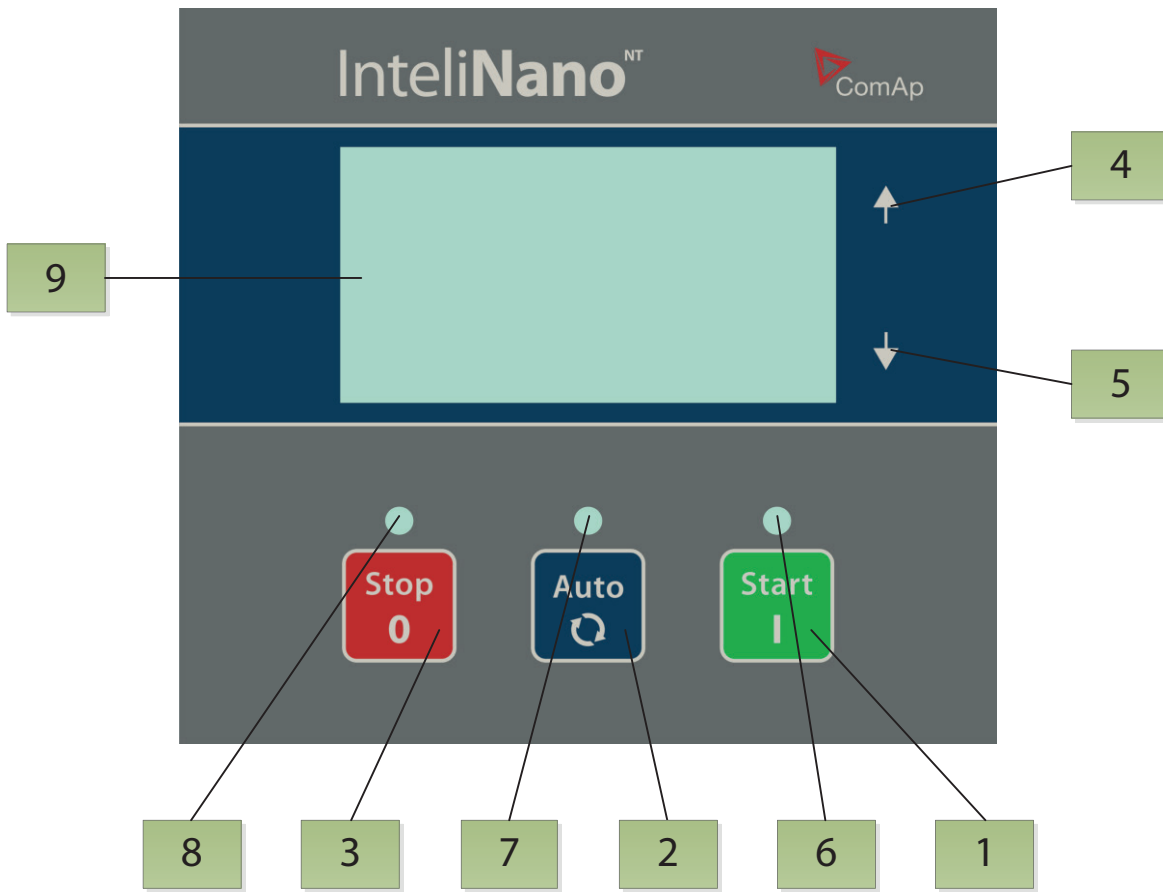

### PULSANTI DI CONTROLLO DEL GRUPPO ELETTROGENO

POSIZIONE	PULSANTE	DESCRIZIONE
1		<b>PULSANTE START</b> <b>START</b> . Funziona solo in modalità Manuale. Premere questo pulsante per iniziare la sequenza di avviamento del motore solo in modalità Manuale. Questo pulsante è anche usato per confermare le modifiche durante la programmazione.
2		<b>PULSANTE AUTO</b> <b>AUTO</b> . E' dedicato al passaggio tra le modalità operative Manuale e Auto.
3		<b>PULSANTE STOP</b> <b>STOP</b> . Premere questo pulsante per iniziare la sequenza di arresto quando il motore è in moto solo in modalità Manuale. Questo pulsante è anche usato per cancellare le modifiche durante la programmazione, per tornare indietro, per uscire e per confermare un allarme.
4		<b>Pulsante</b> per muoversi verso l'alto o aumentare i valori.
5		<b>Pulsante</b> per muoversi verso il basso o per diminuire i valori.

### INDICATORI DEL GRUPPO ELETTROGENO

POSIZIONE	DESCRIZIONE DELL'INDICATORE
6	<b>Funzionamento del motore.</b> Il LED verde lampeggia se il motore è nelle fasi di avviamento, raffreddamento o di arresto. Quando il LED è acceso il motore è in moto con il carico collegato o pronto a prendere il carico.
7	<b>Modalità operativa.</b> Quando il LED verde è acceso il controller è in modalità AUTO. Quando è spento il controller è in modalità Manuale.
8	<b>LED rosso di allarme.</b> Il LED lampeggerà quando sono attivi uno o più avvertimenti (warning) o allarmi (shutdown). Il LED è acceso quando l'allarme attivo è confermato, il motore non può essere avviato.
9	Display grafico in Bianco/Nero, 128x64 pixels.

## 2. AVVIAMENTO E ARRESTO DEL MOTORE

### 2.1 Modalità Manuale (in AMF)

Il LED verde sopra il pulsante **AUTO** è spento (il controller è in modalità Manuale). Quando non c'è nessun allarme attivo (shutdown) è possibile avviare il motore premendo il pulsante **START**. Il LED verde sopra il pulsante lampeggerà. Il LED lampeggia durante le fasi di avviamento, raffreddamento e arresto. Quando il motore è già avviato il LED smetterà di lampeggiare e rimane a luce fissa, il generatore è pronto a prendere il carico. Premendo ancora **START** si aprirà MCB. Un'altra pressione di questo pulsante chiuderà GCB.

Premere il pulsante **STOP** per arrestare il motore. La prima pressione aprirà GCB, la successiva chiuderà MCB. Premendo ancora il pulsante **STOP** inizierà la sequenza di raffreddamento e arresto del motore. Una ulteriore pressione arresterà immediatamente il motore. Per rendere più veloce il trasferimento del carico e l'arresto del motore premere e tenere premuto il pulsante **STOP** fino a quando il carico sarà trasferito e il motore fermato.

### 2.2 Modalità Manuale (in MRS)

Il LED verde sopra il pulsante **AUTO** è spento (il controller è in modalità Manuale). Quando non c'è nessun allarme attivo (shutdown) è possibile avviare il motore premendo il pulsante **START**. Il LED verde sopra il pulsante lampeggerà. Il LED lampeggia durante le fasi di avviamento, raffreddamento e arresto. Quando il motore è già avviato il LED smetterà di lampeggiare e rimane a luce fissa, il generatore è pronto a prendere il carico. Premendo ancora **START** si chiuderà GCB – solo quando GCB è configurato.

Premere il pulsante **STOP** per arrestare il motore. La prima pressione aprirà GCB, la successiva inizierà la sequenza di raffreddamento e arresto del motore. Un'ulteriore pressione arresterà immediatamente il motore. Per rendere più veloce l'arresto del motore premere e tenere premuto il pulsante **STOP** fino a quando il motore è fermo.

### 2.3 Modalità Auto (in AMF)

Il LED verde sopra il pulsante **AUTO** è acceso (il controller è in modalità Auto). Non è possibile avviare il motore o trasferire il carico premendo il pulsante **START**. Il controller avvierà automaticamente il motore quando tutte le condizioni per l'avviamento e il trasferimento del carico saranno raggiunte. Il motore in modalità Auto non può essere fermato premendo il pulsante **STOP**. Il motore può essere avviato e fermato attraverso l'ingresso binario Remote Start/stop o Remote Start And Load.

### 2.4 Modalità Auto (in MRS)

Il LED verde sopra il pulsante **AUTO** è acceso (il controller è in modalità Auto). Non è possibile avviare il motore o collegare il carico premendo il pulsante **START**.

Il controller avvierà automaticamente il motore quando tutte le condizioni per l'avviamento e collegamento del carico saranno raggiunte. Il motore in modalità Auto non può essere fermato premendo il pulsante **STOP**. Il motore può essere avviato e fermato attraverso l'ingresso binario Remote Start/stop o Remote Start And Load.

### 3. STRUTTURA DELLE PAGINE

Le informazioni visualizzate sono strutturate in pagine. Usare i pulsanti ▲ e ▼ per muoversi.

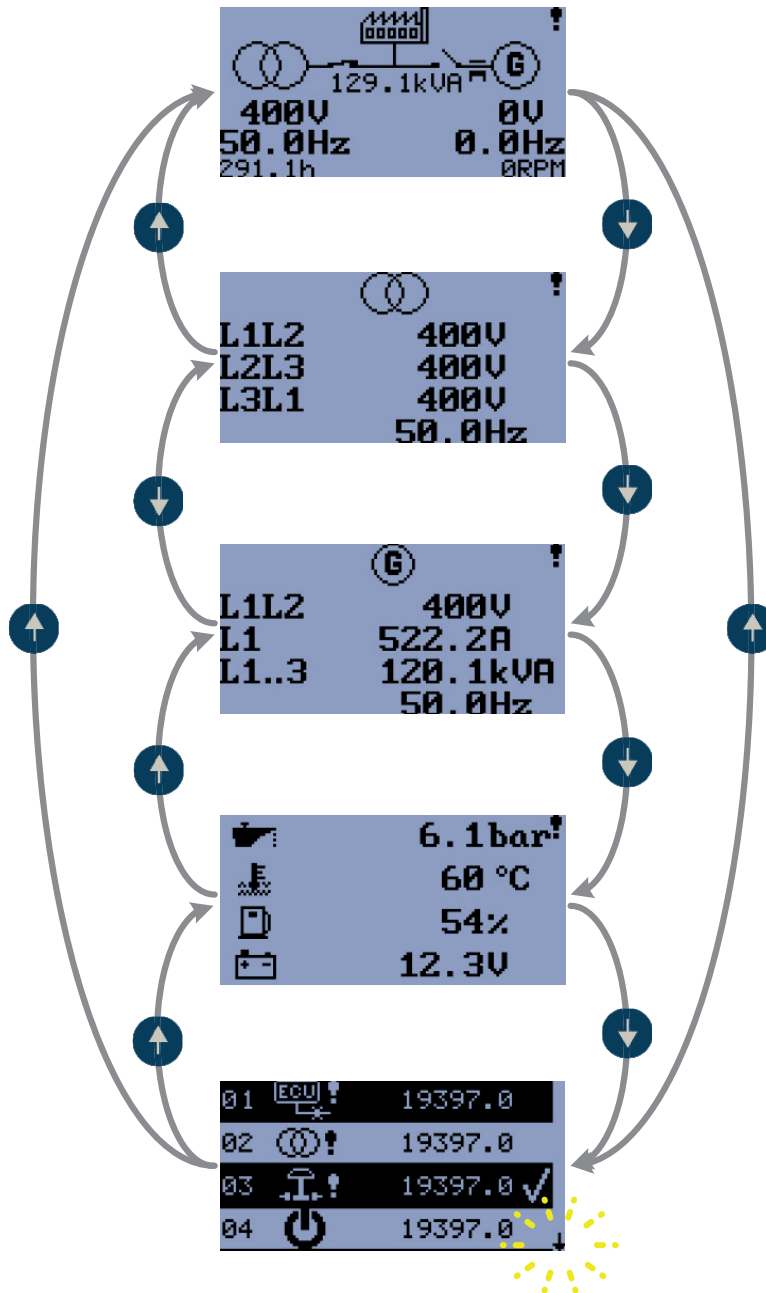

#### 3.1 Struttura delle pagine principali (in AMF)

La prima pagina contiene le informazioni base sulle misure di tensione e frequenza di rete e generatore. Sono anche visualizzate le posizioni (stati) di MCB e GCB, le ore di funzionamento la potenza erogata dal generatore e il N° di giri del motore. Quando si verifica qualsiasi tipo allarme il simbolo generale di avvertimento sarà visualizzato sull'angolo alto a destra del display.

La seconda pagina contiene informazioni dettagliate su tensioni e frequenza di rete.

La terza pagina contiene informazioni dettagliate del generatore: tensione, corrente, potenza e frequenza.

La quarta pagina mostra informazioni sul motore – pressione olio; temperatura acqua; livello carburante e tensione di batteria.

La quinta pagina mostra gli ultimi allarmi o eventi.

#### 3.2 Struttura delle pagine principali (in MRS)

La prima pagina contiene le informazioni base sulle misure di tensione e frequenza del solo generatore.

E' anche visualizzata la posizione (stat0) di GCB (solo se configurato), le ore di funzionamento, la potenza erogata dal generatore e il N° di giri del motore. Quando si verifica qualsiasi tipo di allarme il simbolo generale di avvertimento sarà visualizzato sull'angolo alto a destra del display.

La seconda pagina contiene informazioni dettagliate del generatore: tensione, corrente, potenza e frequenza.

La terza pagina mostra informazioni sul motore – pressione olio; temperatura acqua; livello carburante e tensione di batteria.

La quarta pagina mostra gli ultimi allarmi o eventi.



#### 4. ALLARMI, EVENTI E GESTIONE DELLE REGISTRAZIONI

I seguenti allarmi e registrazioni sono disponibili:

- Eventi
- Avvertimenti
- Allarmi (shutdowns)
- Messaggi ECU

Quattro registrazioni possono essere visualizzate contemporaneamente sullo schermo LCD. La capacità totale è di 10 registrazioni, la figura è un esempio di come è organizzato lo storico. La pagina in questo esempio sta mostrando gli ultimi quattro eventi. Per vedere le altre registrazioni memorizzate si deve attendere 3 secondi sino a che smette di lampeggiare la freccia in basso, poi premere il pulsante ▼.

Per la conferma degli allarmi (shutdown) premere il pulsante Stop.

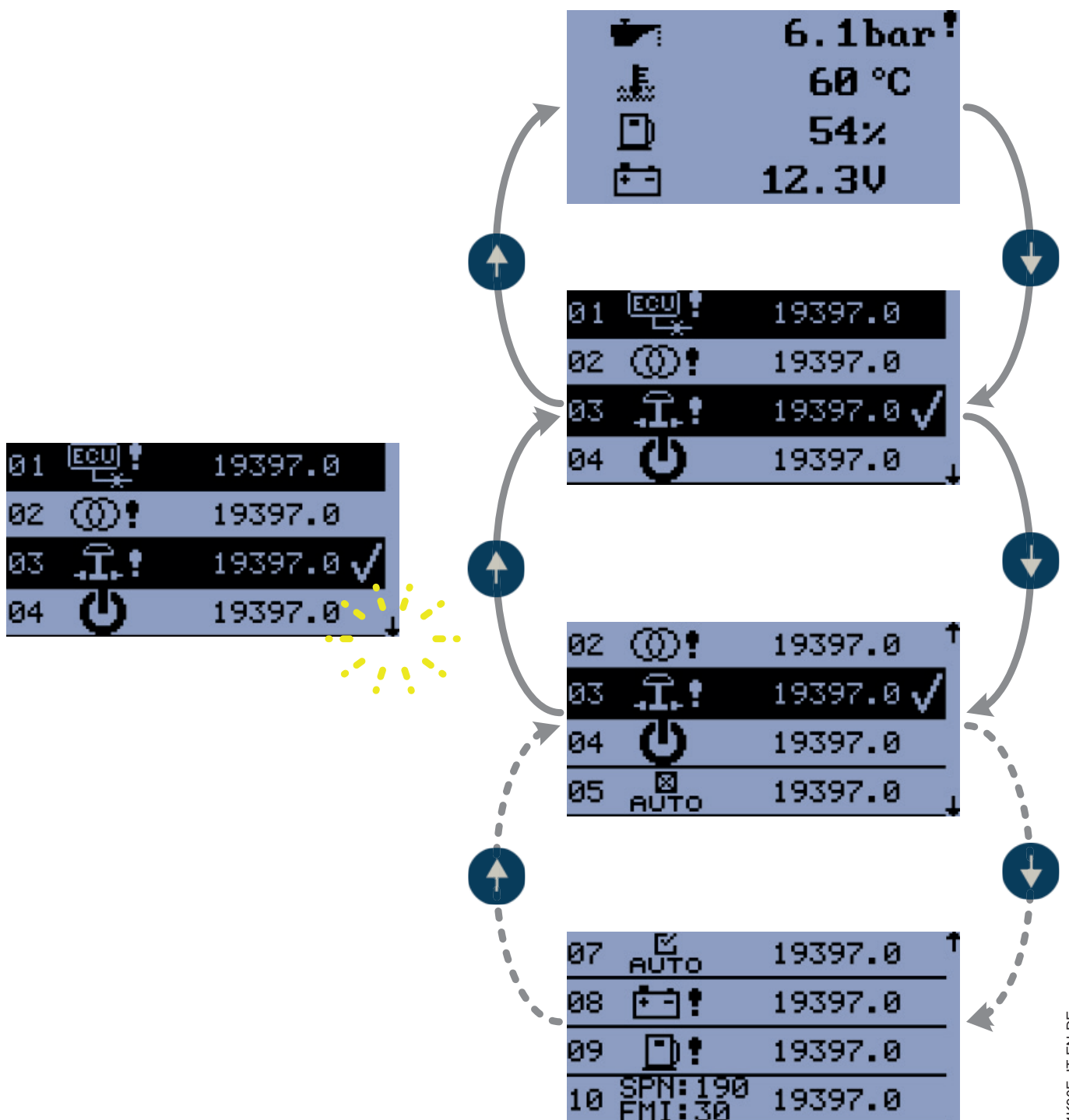

#### 4.1 Eventi

Ogni evento elencato nella tabella che segue viene salvato nello storico affiancato dalle ore di funzionamento, si veda la figura.



#### EVENTI POSSIBILI

	<b>Rientro rete</b> Tutti i parametri di rete sono all'interno dei campi impostati.
	<b>Mancanza rete</b> Il rilevamento di mancanza rete dipende dalle impostazioni di setpoint.
	<b>Avviamento manuale</b> Il motore è stato avviato manualmente premendo il pulsante <b>START</b> in modalità Manuale.
	<b>Avviamento Remoto</b> Il motore è stato avviato da remoto attraverso la funzione del terminale d'ingresso I02 Remote Start/Stop o I03 Remote Start And Load. Il controller è in modalità Auto.
	<b>Avviamento AMF</b> Il motore è stato automaticamente avviato a causa di mancanza rete. Il controller è in modalità Auto.
	<b>Arresto manuale</b> Il motore è stato arrestato manualmente premendo il pulsante <b>STOP</b> in modalità Manuale.
	<b>Arresto Remoto</b> Il motore è stato arrestato da remoto attraverso la funzione del terminale d'ingresso I02 Remote Start/Stop o I03 Remote Start And Load. Il controller è in modalità Auto.
	<b>Arresto AMF</b> Il motore è stato automaticamente arrestato a causa del trasferimento del carico alla rete. Il controller è in modalità Auto.
	<b>Auto ON</b> La modalità Auto è attivata.
	<b>Auto OFF</b> La modalità Auto è disattivata.
	<b>Alimentazione</b> Il controller è acceso.
	<b>Funzionamento in isola</b> Il carico è alimentato dal generatore.

## 4.2 Avvertenze

### 4.2.1 Avvertimento attivo

Quando si verifica un avvertimento, l'uscita allarme O04 si chiude e il LED rosso sopra pulsante Stop lampeggia. Il simbolo generale di avvertimento lampeggerà nell'angolo in alto a destra dello schermo LCD e il simbolo corretto verrà visualizzato nello storico con le ore di funzionamento. Un avvertimento attivo non può essere confermato. Vedi l'elenco dei possibili avvertimenti.



AVVERTIMENTO ATTIVO - BATTERIA SCARICA







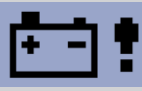

### 4.2.2 Avvertimento non attivo

Quando un avvertimento non è attivo, l'uscita allarme O04 si apre, il LED rosso sopra pulsante Stop smetterà di lampeggiare e il simbolo generale di avvertimento sulla pagina principale si spegnerà.



AVVERTIMENTO NON ATTIVO - BATTERIA SCARICA

### 4.2.3 Avvertimenti possibili

	<p><b>Attenzione Manutenzione</b> L'intervallo di manutenzione è determinato dal valore di Setpoint E07 Manutenzione. La protezione si attiva quando le ore di funzionamento del motore raggiungono questo valore.</p>
	<p><b>Batteria scarica (guasto sul carica batteria)</b> Questo avviso si verifica se la tensione di batteria è inferiore al limite prestabilito di sotto tensione di batteria per più di 30 secondi. Questo avviso si verifica anche in caso di guasto dell'alternatore di carica batteria.</p>
	<p><b>Basso livello carburante</b> Questo avviso si verifica quando l'ingresso analogico Livello Carburante è inferiore al 20% o l'ingresso binario Livello Carburante rimane chiuso per più di 10 secondi.</p>
	<p><b>Attenzione esterno 1</b> Questo avviso si verifica quando l'ingresso External Warning 1 è attivato.</p>
	<p><b>Attenzione esterno 2</b> Questo avviso si verifica quando l'ingresso External Warning 2 è attivato.</p>
	<p><b>Attenzione esterno 3</b> Questo avviso si verifica quando l'ingresso External Warning 3 è attivato.</p>
	<p><b>Errore di comunicazione ECU</b> Questo avviso si attiva quando la ECU (se configurata) non comunica e tutti i valori della ECU sono visualizzati sul display con #####.</p>
	<p><b>Fallimento di MCB.</b> Azione fallita del contattore di rete MCB.</p>
	<p><b>Sequenza fase di RETE anti-oraria (CCW)</b> Errata sequenza fase di RETE ( anti-oraria CCW).</p>

### 4.3 Allarmi

#### 4.3.1 Procedura di arresto (shutdown)

Il controller InteliNano Plus apre le uscite O05 GCB Close/Open, O01 Starter, O08 Prestart e Fuel Solenoid e chiude O03 Stop Solenoid per fermare immediatamente il motore. L'uscita O04 Alarm viene chiusa. Protezioni attive o non confermate disabilitano l'avviamento.

#### 4.3.2 Allarme (shutdown) attivo non confermato.

Quando si verifica un arresto, la procedura di spegnimento avrà inizio, il LED rosso sopra il pulsante Stop lampeggia, il simbolo generale di attenzione lampeggerà nell'angolo in alto a destra dello schermo LCD, e il simbolo corretto di spegnimento verrà visualizzato nello storico con le ore di funzionamento. La registrazione nello storico è negativa, si veda la figura. Vedi l'elenco dei possibili allarmi (shutdown). Per la conferma di un allarme (shutdown) premere il pulsante Stop.



ALLARME (SHUTDOWN) ATTIVO NON CONFERMATO - STOP D'EMERGENZA

#### 4.3.3 Allarme (shutdown) attivo confermato.

Quando un arresto attivo viene confermato il LED rosso sopra il pulsante di Stop smette di lampeggiare. La registrazione nello storico rimane negativa con il simbolo di conferma alla fine. L'uscita O04 Alarm è aperta.



ALLARME (SHUTDOWN) ATTIVO CONFERMATO - STOP D'EMERGENZA

#### 4.3.4 Allarme (shutdown) non attivo non confermato

L'uscita O04 Alarm è chiusa, il LED rosso sopra il pulsante Stop lampeggia. il simbolo generale di attenzione lampeggerà nell'angolo in alto a destra dello schermo LCD, e il simbolo corretto di attenzione verrà visualizzato nello storico con le ore di funzionamento. Vedi l'elenco dei possibili allarmi (shutdown). Per la conferma di un allarme (shutdown) premere il pulsante Stop.



ALLARME (SHUTDOWN) NON ATTIVO NON CONFERMATO - STOP D'EMERGENZA





#### 4.3.5 Allarme (shutdown) non attivo confermato





L'uscita O04 Alarm è aperta. E' possibile avviare il motore se tutti gli allarmi (shutdowns) sono non attivi e confermati.



ALLARME (SHUTDOWN) NON ATTIVO CONFERMATO - STOP D'EMERGENZA

## 4.3.6 Allarmi (shutdown) possibili

	<b>Stop d'Emergenza</b> L'ingresso binario Emergency Stop è stato attivato.
	<b>Sovra-velocità</b> La protezione diventa attiva se la velocità è maggiore del 115% della velocità nominale del motore, la quale è derivata dalla frequenza del generatore.
	<b>Sotto-velocità</b> Bassi giri del motore. Questo allarme viene emesso quando il gruppo elettrogeno è in funzione e poi si ferma da solo, cioè il numero di giri scende al di sotto del numero di giri nominale del motore. L'allarme sotto-velocità comincia ad essere valutato 5 secondi dopo l'avviamento del generatore e viene valutato per tutto il tempo in cui l'uscita Fuel Solenoid è chiusa.
	<b>Bassa pressione olio</b> Il motore si ferma quando la pressione dell'olio scende o è inferiore a 1 bar o l'ingresso binario I22 Low Oil Pressure è attivo.
	<b>Alta temperatura liquido di raffreddamento</b> Il motore si ferma quando la temperatura del liquido di raffreddamento supera la soglia di Coolant Temperature Shutdown.
	<b>Allarme esterno 1</b>
	<b>Allarme esterno 2</b>
	<b>Allarme esterno 3</b>
	<b>Fallimento di GCB.</b> Azione fallita del contattore di generatore GCB
	<b>Sovra-tensione generatore</b> Il Generatore si fermerà quando la tensione di uscita supera la soglia impostata in G01 Generator Overvoltage Shutdown.
	<b>Sotto-tensione generatore</b> Il Generatore si fermerà quando la tensione di uscita scende sotto la soglia impostata in G02 Generator Underoltage Shutdown.
	<b>Sovra-frequenza generatore</b> La frequenza del generatore è fuori dai limiti dati nelle impostazioni G03 Generator Overfrequency Shutdown and G04 Generator Underfrequency Shutdown .
	<b>Sotto-frequenza generatore</b> La frequenza del generatore è fuori dai limiti dati nelle impostazioni G03 Generator Overfrequency Shutdown and G04 Generator Underfrequency Shutdown .
	<b>Sequenza fase di GENERATORE anti-oraria (CCW)</b> Errata sequenza fase di GENERATORE (anti-oraria CCW).
	<b>Avviamento mancato</b> Mancato avviamento del generatore.
	<b>Arresto mancato</b> Mancato arresto del generatore

	<b>Batteria scarica</b> Se il controller perde l'alimentazione durante la sequenza di avviamento a causa delle cattive condizioni della batteria, non tenterà di riavviare il motore e attiverà questa protezione.
	<b>Rilevazione Automatica della tensione</b> Se si utilizza per l'impostazione di B04 "Connection Type" la rilevazione automatica e, la tensione misurata del generatore non corrisponde ai valori predefiniti per il particolare tipo di connessione viene visualizzato l'allarme.
	<b>Corto circuito generatore</b> Se la corrente del generatore supera il limite di corrente pre-impostato.
	<b>Allarme (shutdown) basso livello carburante</b> Questo arresto si verifica quando l'ingresso analogico Livello Carburante è inferiore al livello di arresto pre-impostato o l'ingresso binario Fuel Level SD rimane chiuso per più di 10 secondi.

#### 4.4 Messaggi ECU

```
10 SPN:190 19397.0
   FMI:30
```

MESSAGGI ECU

#### Messaggio ECU

I messaggi di diagnostica vengono letti e visualizzati nello storico dietro il simbolo ECU di avvertimento. Sono mostrati i messaggi per gli standard J1939 SPN (Suspect Parameter Number) e FMI (Failure Mode Identifier).

Per le specifiche particolari dei codici SPN / FMI vedere in:

- SAE Truck and Bus Control and Communications Network Standards Manual, pubblicazione SAE HS-1939,
- Oppure far riferimento al corrispondente elenco dei codici di errore ECU del costruttore del motore.

Elenco completo dei messaggi di testo di diagnostica per ogni ECU può essere trovato in ComAp Motori elettronici manuale di supporto.

## 5 IMPOSTAZIONE

### 5.1 Accesso alla modalità di impostazione

Assicurarsi che il motore sia fermo e il controller sia in modalità Manuale (LED verde sopra il pulsante **AUTO** spento). Se non si è configurata la pagina personalizzata di inizializzazione (init) allora premere e tenere premuto il pulsante **STOP**, quindi premere brevemente il pulsante **▲** e poi il pulsante **AUTO**.

Se avete già creato la vostra pagina personalizzata di inizializzazione (init) allora premere e tenere premuto il pulsante **STOP** e quindi premere brevemente il pulsante **▲**, verrà visualizzata la pagina personalizzata di inizializzazione, tenere premuto il pulsante **STOP**. Quindi premere **▼** per passare alla pagina di default, e poi premere **AUTO**.

Per spostarsi su e giù nel menu di impostazione utilizzare **▲** e **▼**. Premere il pulsante **START** per selezionare o il pulsante di **STOP** per l'uscita.

### 5.2 Setpoints

Utilizzare i pulsanti **▲** e **▼** per spostare o modificare il valore. Il pulsante **START** per selezionare il setpoint o confermare le modifiche e il pulsante **STOP** per tornare indietro.

 Setting di base		
Codice setpoint	Nome setpoint	
B01	Tensione nominale L-N	80 – 480 V
B02	Tensione nominale L-L	80 – 600 V
B03	Frequenza Nominale	50 Hz (1), 60 Hz (2)
B04	Tipo di collegamento	Monofase (1), Bifase (2), Trifase 3 fili (3), Trifase 4 fili (4)
B05	Formato misure	Metrico (1), Formato US (2)
B06	Funzione AMF	Disabilitato (1), Abilitato (2)
B07	Ritardo modalità zero Power	0-360 min
B08	Modalità Torre Faro	Disabilitato (1), Abilitato (2)
B09	Corrente nominale	1 - 1000 A
B10	Rapporto CT (trasf. amperometrico)	1 - 5000 A
B11	Giri motore nominali	100-4000

## Uscite ed ingressi



## Protezione e parametri motore

Codice setpoint	Nome setpoint	
E01	Tempo di Prestart	0-600 s
E02	Tempo max di avviamento	0-60 s
E03	Tempo di raffreddamento	0-3600 s
E04	Arresto pressione olio	0-10 Bar
E05	Arresto temperatura	0 - 150 °C
E06	Sotto-tensione batteria	8 - 40 V
E07	Allarme manutenzione	0 - 10000 h
E08	Sgancio avviamento da pressione olio	Disabilitato (1), Abilitato (2)
E09	Tempo aria	0 - 3600 s
E10	Tempo minimo di stabilizzazione	1 - 300 s
E12	Tentativi di avviamento	1 - 10
E15	Arresto livello carburante	0 - 20%



## Protezione generatore

Codice setpoint	Nome setpoint	
G01	Arresto sovra-tensione	G02 - 200 %
G02	Arresto sotto-tensione	0 - G01 %
G03	Arresto sovra-frequenza	G04 - 130 %
G04	Arresto sotto-frequenza	0 - G03 %
G05	Arresto corto circuito	100 - 500 %
G06	Ritardo arresto corto circuito	0 - 10,00 s



## AMF (Auto Mains Failure) setting

Codice setpoint	Nome setpoint	
A01	Ritardo avviamento emergenza	0 - 600 s
A02	Ritardo ritorno rete	1 - 3600 s
A03	Sovra-tensione di rete	A04 - 150 %
A04	Sotto-tensione di rete	50 - A03
A05	Sovra-frequenza di rete	A06 - 150 %
A06	Sotto-frequenza di rete	50 - A05 %

Codice uscite	Uscite	Tipo	Terminali assegnati
O00	Non Usato	binario	T04 , T05, T06, T07, T08, T09
O01	Avviamento	binario	T04
O02	Elettrovalvola	binario	T05, T06, T07, T08, T09
O03	Solenoide Stop	binario	T05, T06, T07, T08, T09
O04	Allarme	binario	T04, T05, T06, T07, T08, T09
O05	Apri/Chiudi GCB	binario	T04, T05, T06, T07, T08, T09
O06	Apri/Chiudi MCB	binario	T04, T05, T06, T07, T08, T09
O07	Pronto per presa di carico	binario	T04, T05, T06, T07, T08, T09
O08	Prestart	binario	T04, T05, T06, T07, T08, T09
O09	Alimentazione ECU	binario	T04, T05, T06, T07, T08, T09
O10	Aria	binario	T04 , T05, T06, T07, T08, T09
O11	Candele preriscaldamento	binario	T04 , T05, T06, T07, T08, T09

**Uscite ed ingressi**

Code ingressi	Ingressi	Tipo	Terminali assegnati
I00	Non usato	binario	T07, T11, T12, T13, T14, T15
I01	Stop d'emergenza	binario	T07, T11, T12, T13, T14, T15
I02	Start/Stop a distanza	binario	T11
I03	Start/Stop a distanza con presa di carico	binario	T11
I04	Accesso bloccato	binario	T07, T11, T12, T13, T14, T15
I05	Funzione AMF bloccata	binario	T07, T11, T12, T13, T14, T15
I06	Indicazione stato MCB	binario	T07, T11, T12, T13, T14, T15
I07	Indicazione stato GCB	binario	T07, T11, T12, T13, T14, T15
I10	Allarme esterno 1	binario	T07, T11, T12, T13, T14, T15
I11	Allarme esterno 2	binario	T07, T11, T12, T13, T14, T15
I12	Allarme esterno 3	binario	T07, T11, T12, T13, T14, T15
I13	Arresto esterno 1	binario	T07, T11, T12, T13, T14, T15
I14	Arresto esterno 2	binario	T07, T11, T12, T13, T14, T15
I15	Arresto esterno 3	binario	T07, T11, T12, T13, T14, T15
I20	Basso livello carburante	binario	T07, T11, T12, T13, T14, T15
I21	Livello carburante analogico	analogico	T13, T14, T15
I22	Bassa pressione olio	binario	T07, T11, T12, T13, T14, T15
I23	Pressione olio analogico	analogico	T13, T14, T15
I24	Alta temperatura	binario	T07, T11, T12, T13, T14, T15
I25	Temperatura analogico	analogico	T13, T14, T15
I29	Arresto livello carburante	binario	T07, T11, T12, T13, T14, T15

	Contatto normalmente aperto – uscita		Contatto normalmente aperto – Ingresso
	Contatto normalmente chiuso – uscita		Contatto normalmente chiuso – Ingresso

**Curve sensori analogici**

	I21	I23	I25
	VDO Level %	VDO 5 Bar	VDO 40-120 °C
	Datcon Level %	VDO 10 Bar	VDO 50-150 °C
		Datcon 5 Bar	Datcon High °C
		Datcon 7 Bar	Datcon Low °C
		Datcon 10 Bar	
	NON selezionato	NON selezionato	NON selezionato

Per applicare tutte le modifiche tornare al menu principale e riavviare il controller premendo il pulsante Stop.

Per la configurazione della ECU utilizzare il software per PC NanoEdit. Per maggiori dettagli consultare **InteliNano AMF Reference Guide**.



## 6 DATI TECNICI

Campo/Alimentazione	6-36VDC
Immunità alla mancanza di alimentazione	100ms
Assorbimento	35 - 95 mA
Assorbimento in modalità zero power	52 - 344 $\mu$ A
Temperatura di funzionamento	-20... 70°C
Umidità di funzionamento	95% senza condensa (IEC/EN 60068-2-30)
Grado di protezione (frontale)	IP65 - solo con guarnizione 4x405 IP50 - senza guarnizione
Temperatura di magazzino	-30... 80°C
Ingressi binari (fino a 6)	
Resistenza d'ingresso	1.5 k $\Omega$
Tensione contatto chiuso	<2V
Tensione contatto aperto	>3.5V
Uscite binarie (fino a 6)	
Uscite bassa corrente (4)	500 mA
Uscite ad alta corrente (2)	6A - (continua) / 10A (Breve) (L $\leq$ 500mH)
Totale corrente d'uscita	10A - (continua) / 16A - (Breve) (L $\leq$ 500mH)
Misure di Generatore / Rete	
Misure in ingresso	Tensione generatore monofase, corrente monofase, tensione di rete trifase
Tipo di misura	Vero RMS
Campo di tensione	480V L-L (277V L-N)
Max. tensione misurata	340V L-N
Precisione sulla tensione	1 %
Campo di frequenza	40-70 Hz
Precisione sulla frequenza	1 %
Campo di corrente	0 - 5 A
Precisione sulla corrente	2% Vero RMS
Circuito di pre-eccitazione per alternatore carica CB	
Corrente di eccitazione	100 mA
Soglia di guasto	80%
Porta USB	1
Tipo	CAN bus
Isolamento galvanico	No
Baud rate	250 kbps
Lunghezza Bus	max. 200m
Resistenza terminale	120 Ohm, interna, con ponticello

## 7 PROCEDURA RESET ALLARME ORE/MANUTENZIONE

POSIZIONE	PULSANTE	DESCRIZIONE
1		Spegnere Tasto <b>AUTO</b>
2		Tenere premuto <b>STOP</b> e in sequenza premere   <b>AUTO</b>
3		Appare la schermata
4		Spostarsi sul  con  e premere <b>START</b>
5		Spostarsi fino a <i>E07</i> e premere <b>START</b>
6		Impostare le ore del successivo intervento di manutenzione. (Impostare le ore seguendo le istruzioni del libretto d'uso e manutenzione del motore o le indicazioni del manutentore)
7		Premere <b>STOP</b> 3 volte per uscire



## USE AND MAINTENANCE MANUAL

TRANSLATION OF THE ORIGINAL INSTRUCTIONS — ENGLISH

# COMAP InteliNano PLUS

Codice  
Code  
Code  
Codigo  
Kodezahl  
Código

MCM1K90F9003

- Unità controllo motore
- Engine control unit
- Protection moteur
- Motorschutz

- Unidad control motor
- Unidade de controlo do motor

Edizione  
Edition  
Édition  
Edición  
Ausgabe  
Edição

07.2019





.....

**1. OPERATOR INTERFACE ..... PAG.22**

**2. START AND STOP ENGINE ..... PAG.23**

    2.1 *AMF IN MANUAL MODE..... PAG.23*

    2.2 *MRS IN MANUAL MODE..... PAG.23*

    2.3 *AMF IN AUTO MODE..... PAG.23*

    2.4 *MRS IN AUTO MODE..... PAG.23*

**3. DISPLAY SCREENS STRUCTURE ..... PAG.24**

    3.1 *AMF MAIN SCREENS STRUCTURE..... PAG.24*

    3.2 *MRS MAIN SCREENS STRUCTURE..... PAG.24*

**4. ALARMS, EVENTS AND HISTORY MANAGEMENT ..... PAG.25**

    4.1 *EVENTS..... PAG.26*

    4.2 *WARNINGS..... PAG.27*

        4.2.1 *ACTIVE WARNING ..... PAG.27*

        4.2.2 *INACTIVE WARNING ..... PAG.27*

        4.2.3 *POSSIBLE WARNINGS..... PAG.27*

    4.3 *SHUTDOWN..... PAG.28*

        4.3.1 *SHUTDOWN PROCEDURE..... PAG.28*

        4.3.2 *ACTIVE UNCONFIRMED SHUTDOWN ..... PAG.28*

        4.3.3 *ACTIVE CONFIRMED SHUTDOWN..... PAG.28*

        4.3.4 *INACTIVE UNCONFIRMED SHUTDOWN ..... PAG.28*

        4.3.5 *INACTIVE CONFIRMED SHUTDOWN..... PAG.28*

        4.3.6 *POSSIBLE SHUTDOWN ALARMS ..... PAG.29*

    4.4 *ECU MESSAGES ..... PAG.30*

**5 SETUP ..... PAG.30**

    5.1 *ACCESSING THE SETUP MODE..... PAG.30*

    5.2 *SETPOINTS..... PAG.30*

**6 TECHNICAL DATE ..... PAG.33**

**7 PROCEDURE FOR HOUR/MAINTENANCE ALERT RESET ..... PAG.34**

## 1. OPERATOR INTERFACE

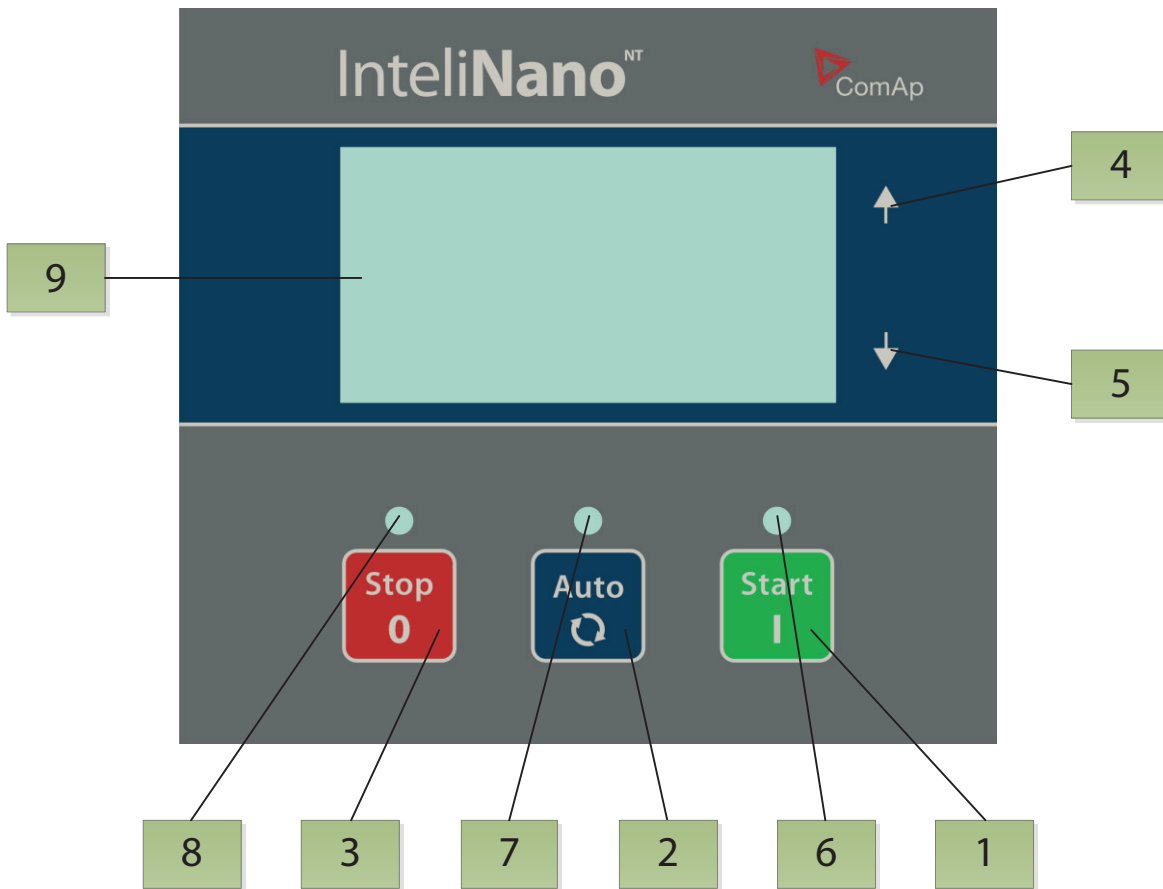

### GEN-SET CONTROL BUTTONS

POSITION	BUTTON	DESCRIPTION
1		<b>START (START) BUTTON.</b> Works in Manual mode only. Press this button to initiate the start sequence of the engine - in Manual operating mode only. This button is also used to confirm changes in setup mode.
2		<b>AUTO (AUTO) BUTTON</b> is dedicated for switching between auto and manual operating mode.
3		<b>STOP (STOP) BUTTON.</b> Press this button to initiate the stop sequence of the gen-set when engine is running - in Manual operating mode only. This button is also used to cancel changes in setup mode, to go back or to exit and for alarm confirmation.
4		<b>UP (▲) BUTTON</b> for move up or value increasing.
5		<b>DOWN (▼) BUTTON</b> for move down or value decreasing.

### GEN-SET OPERATION INDICATORS

POSITION	INDICATOR DESCRIPTION
6	<b>Engine operation.</b> Green LED is blinking, if engine is starting, cooling or stopping. When LED is on the engine is running and is loaded or ready to load.
7	<b>Operating mode.</b> When the green LED is on, the controller is in Auto operating mode. When is off the controller is in Manual mode.
8	<b>Alarm red LED.</b> The LED will blink when there is one or more active warning or active shutdown alarm. The LED is on when the active shutdown alarm is confirmed and the engine can't be started.
9	Graphic B/W display, 128x64 pixels

## 2. START AND STOP ENGINE

### 2.1 AMF in MANUAL mode

Green LED above **AUTO** button is off (controller is in MANUAL mode). When there is no any active shut down alarm you can start the engine by pressing **START** button. Green LED above button will blink. LED is blinking during starting, cooling or stopping procedure. When the engine is already started, the green LED will stop blink and start lights continuously, the generator is ready to load. When you press **START** button again the MCB will open. Another press of this button will close GCB.

Press **STOP** button to stop the engine. First press will open the GCB, next press will close MCB and next press start cooling stopping procedure. When you press this button again the controller will stop engine immediately. For fast load transfer and the engine stop press and hold **STOP** button till load will be transferred and engine stops.

### 2.2 MRS in MANUAL mode

Green LED above **AUTO** button is off (controller is in MANUAL mode). When there is no any active shut down alarm you can start the engine by pressing **START** button. Green LED above button will blink. LED is blinking during starting, cooling or stopping procedure. When the engine is already started, the green LED will stop blink and start lights continuously. The generator is ready to load. When you press **START** button again the GCB will close – only when the GCB is configured.

Press **STOP** button to stop the engine. First press will open the GCB and next press start cooling and stopping procedure. When you press this button again the controller will stop the engine immediately. For fast engine stop press and hold **STOP** button till engine stops.

### 2.3 AMF in AUTO mode

Green LED above **AUTO** button is on (controller is in AUTO mode). You can't start the engine or transfer the load by pressing **START** button. The controller will start automatically when all conditions for start and load transfer will be reached. The engine in AUTO mode can't be stopped by pressing **STOP** button.

Engine can be started or stopped via binary input Remote Start/stop or Remote Start And Load.

### 2.4 MRS in AUTO mode

Green LED above **AUTO** button is on (controller is in AUTO mode). You can't start the engine or connect the load by pressing **START** button. The controller will start automatically when all conditions for start and load connection will be reached. The engine in AUTO mode can't be stopped by pressing **STOP** button. Engine can be started or stopped via binary input Remote Start/stop or Remote Start And Load.

### 3. DISPLAY SCREENS STRUCTURE

The displayed information is structured into "screens". Use ▲ and ▼ button to switch over the screens.

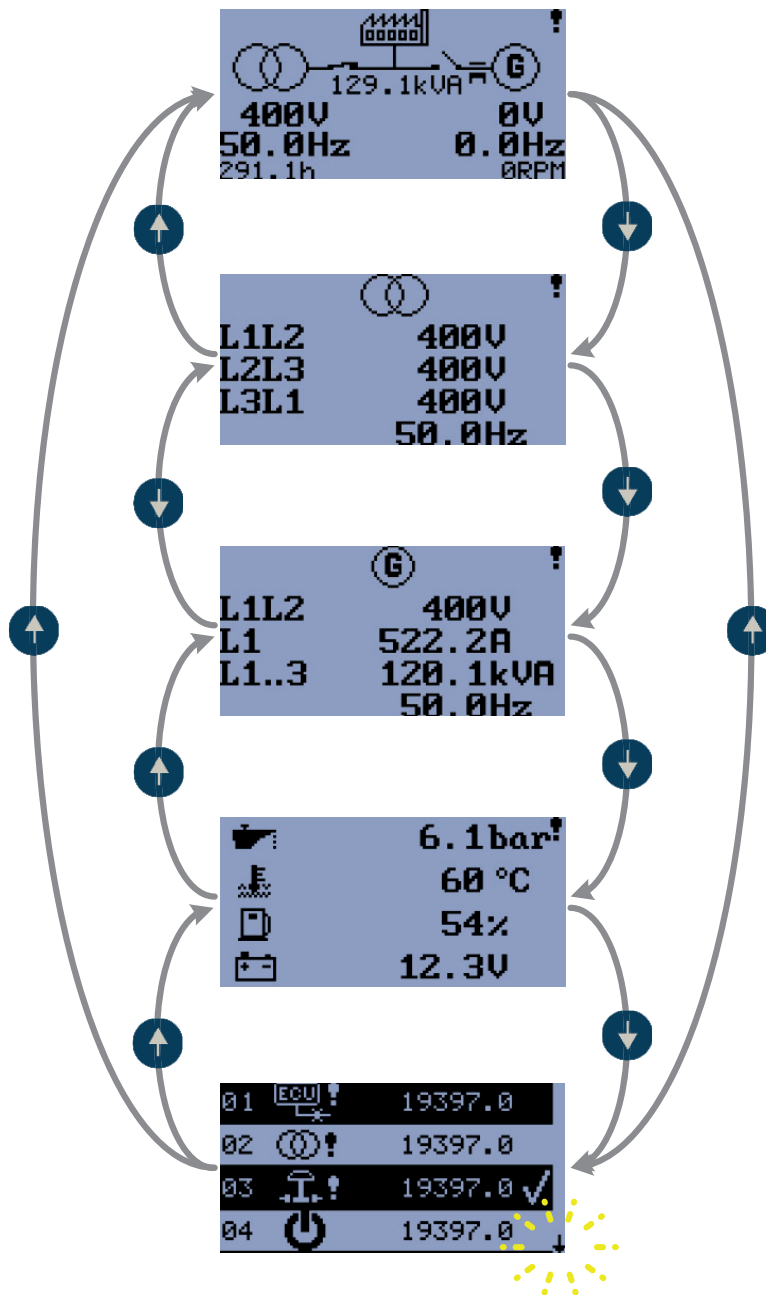

#### 3.1 AMF main screens structure

First screen contain basic information about voltage and frequency measurement on mains and generator side. Also there is displayed position (status) of MCB and GCB, running hours counter, generator power and engine rpm. When any alarm occurs the general warning symbol will be displayed on the LCD's upper right corner.

Second screen contain detail mains voltage and frequency information.

Third screen contain detail generator information: voltage, current, power and frequency.

Fourth screen shows the engine information – oil pressure; coolant temperature; fuel level and battery voltage.

Fifth screen shows last alarms or events.

#### 3.2 MRS main screens structure

First screen contain basic information about voltage and frequency measurement only on generator side.

Also there is displayed position (status) of GCB (only when is configured) , running hours counter, generator power and engine rpm. When any alarm occurs the general warning symbol will be displayed on the LCD's upper right corner.

Second screen contain detail generator information: voltage, current, power and frequency.

Third screen shows the engine information – oil pressure; coolant temperature; fuel level and battery voltage.

Fourth screen shows last alarms or events.



#### 4. ALARMS, EVENTS AND HISTORY MANAGEMENT

Following alarms and records are available:

- Event
- Warnings
- Shutdowns
- ECU Messages

Four records can be displayed simultaneously on the LCD screen. Total capacity is 10 records the figure is an example of how the history is organized. The screen in this example is showing the four latest events.

To view further history records you have to wait 3 second till down arrow stops blink, then press ▼ button.

For alarm (shutdown) confirmation press Stop button.

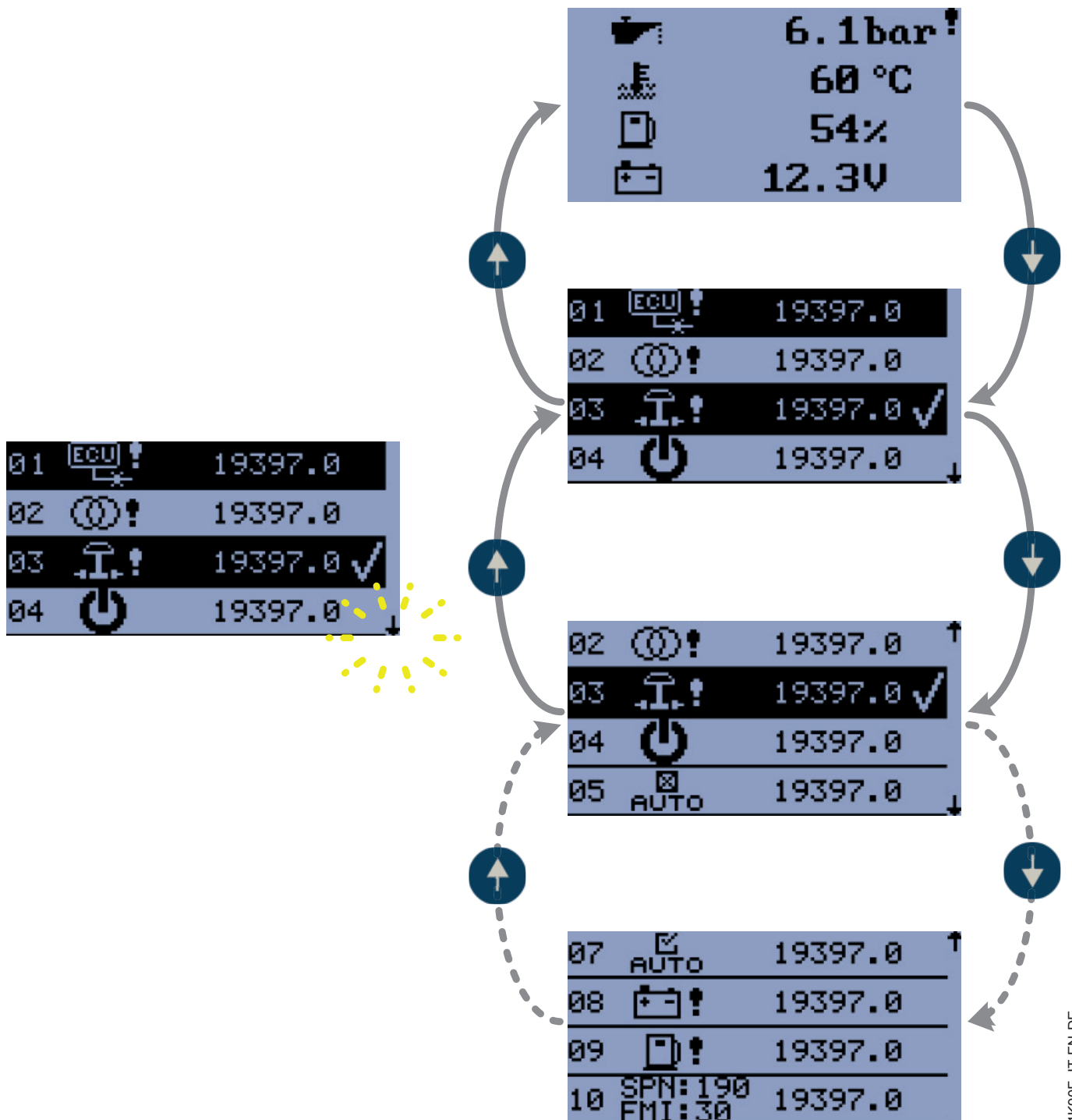













#### 4.1 Events

Every event listed in table below is saved in history with running hours stamp, see figure.



#### POSSIBLE EVENTS

	<b>Mains Return</b> Mains has returned. All mains parameters are within the preset range
	<b>Mains Fail</b> Mains failure detection depends on Auto mains failure setpoints.
	<b>Manual Start</b> Engine was manually started by pressing button <b>START</b> in Manual mode.
	<b>Remote Start</b> Engine was remotely started via input terminal's function I02 Remote Start/Stop or I03 Remote Start And Load. The controller is in Auto mode.
	<b>AMF Start</b> Engine was automatically started because of mains failure. The controller is in Auto mode.
	<b>Manual Stop</b> Engine was manually stopped by pressing button <b>STOP</b> in Manual mode.
	<b>Remote Stop</b> Engine was remotely stopped via input terminal's function I02 Remote Start/Stop or I03 Remote Start And Load. The controller is in Auto mode.
	<b>AMF Stop</b> Engine was automatically stopped because of transfer to mains. The controller is in <b>Auto</b> mode.
	<b>Auto On</b> Auto mode is active.
	<b>Auto Off</b> Auto mode is inactive
	<b>Power On</b> The controller is turned on.
	<b>Island Operation</b> Load is powered from generator.

## 4.2 Warnings

### 4.2.1 Active warning

When a warning occurs, O04 Alarm output will close and the red LED above Stop button will blink. Warning symbol will blink in the upper-right corner of the LCD and the proper warning symbol will be displayed in the history with running hours stamp. Active warning can't be confirmed. See list of possible warnings.



### 4.2.2 Inactive warning

When a warning becomes inactive, O04 Alarm output will open, the red LED above Stop button will stop blinking, and the warning symbol on main screen will go out.



### 4.2.3 Possible warnings

	<p><b>Warning Maintenance</b> The service interval is determined by the setpoint E07 Maintenance. The protection becomes active when the engine running hours reach this value.</p>
	<p><b>Low Battery (Charging Fail)</b> This warning comes up if the battery voltage is lower than preset Battery Undervoltage limit for longer than 30s. This warning also comes up when charging alternator fail.</p>
	<p><b>Low Fuel Level</b> This warning occurs when analog input Fuel Level is below 20% or binary input Fuel Level is closed longer than 10s.</p>
	<p><b>External Warning 1</b> This warning occurs when external warning 1 input is activated.</p>
	<p><b>External Warning 2</b> This warning occurs when external warning 2 input is activated.</p>
	<p><b>External Warning 3</b> This warning occurs when external warning 3 input is activated.</p>
	<p><b>ECU Communication Error</b> This warning is activated when the ECU (if configured) is not communicating and all values from ECU show #####.</p>
	<p><b>MCB Fail</b> Failure of mains circuit breaker.</p>
	<p><b>Mains CCW Rotation</b> Wrong mains phase sequence.</p>

### 4.3 Shutdowns

#### 4.3.1 Shutdown procedure

The IntelliNanoNT Plus controller opens outputs O05 GCB Close/Open, O01 Starter, O08 Prestart and O02 Fuel Solenoid and closes O03 Stop Solenoid to stop the engine immediately. O04 Alarm output is closed. Active or not confirmed protection disables start.

#### 4.3.2 2 Active unconfirmed shutdown

When a shutdown occurs, the Shutdown procedure will start, the red LED above Stop button blinks, the shutdown symbol will blink in the upper right corner of LCD, and the proper shutdown symbol is displayed in history with running hours stamp. The record in history is negative, see figure. See list of possible shutdown alarms. For shutdown alarm confirmation press Stop button.



ACTIVE UNCONFIRMED SHUTDOWN – EMERGENCY STOP

#### 4.3.3 Active confirmed shutdown

When an active shutdown is confirmed the red LED above the Stop button stops blinking. The record in history stays negative with confirmation symbol at the end. **O04 Alarm** output is open.



ACTIVE CONFIRMED SHUTDOWN – EMERGENCY STOP

#### 4.3.4 Inactive unconfirmed shutdown

**O04 Alarm** output is closed, red LED above Stop button blinks. Shutdown symbol is displayed in upper-right corner of the LCD, and proper warning symbol is displayed in history with running hours stamp. See list of possible shutdown alarms. For shutdown alarm confirmation press Stop button.



INACTIVE UNCONFIRMED SHUTDOWN – EMERGENCY STOP

















#### 4.3.5 Inactive confirmed shutdown





**O04 Alarm** output is opened. It is possible to start engine when all shutdowns are inactive and confirmed.



INACTIVE CONFIRMED SHUTDOWN – EMERGENCY STOP

## 4.3.6 Possible shutdown alarms

	<b>Emergency Stop</b> The binary input Emergency Stop was activated.
	<b>Overspeed</b> The protection comes active if the speed is greater than 115% of nominal engine RPM, which is derived from generator frequency.
	<b>Underspeed</b> Low engine RPM. This alarm will be issued when the gen-set is running and then stops by itself, i.e. the RPM drops under the nominal engine RPM. The underspeed alarm starts to be evaluated 5 sec after successful gen-set start and is being evaluated all the time the Fuel Solenoid is on.
	<b>Low Oil Pressure</b> Engine will stop when oil pressure declined to or less than 1 bar or binary input I22 Low Oil Pressure is active.
	<b>High Coolant temperature</b> Engine will stop when temperature of coolant exceed Coolant Temperature Shutdown threshold.
	<b>External Shutdown 1</b>
	<b>External Shutdown 2</b>
	<b>External Shutdown 3</b>
	<b>GCB Fail</b> Failure of generator circuit breaker.
	<b>Generator Overvoltage</b> Generator will stop when output voltage exceeds the preset threshold G01 Generator Overvoltage Shutdown.
	<b>Generator Undervoltage</b> Generator will stop when output voltage drops below the preset threshold G02 Generator Undervoltage Shutdown.
	<b>Generator Overfrequency</b> The generator frequency is out of limits given by setpoints G03 Generator Overfrequency Shutdown and G04 Generator Underfrequency Shutdown.
	<b>Generator Underfrequency</b> The generator frequency is out of limits given by setpoints G03 Generator Overfrequency Shutdown and G04 Generator Underfrequency Shutdown.
	<b>Generator CCW Rotation</b> Incorrect generator phase sequence.
	<b>Start Fail</b> Gen-set start failed.
	<b>Stop Fail</b> Gen-set stop failed.

	<b>Battery Flat</b> If the controller loses power during starting sequence due to bad battery condition, it will not try to start again and will activate this protection.
	<b>Voltage Autodetect</b> If generator voltage measured doesn't correspond with predefined values for particular connection type when Autodetect value for B04 Connection Type is used.
	<b>Generator Short Circuit</b> If the generator generator current exceed preset current limit.
	<b>Fuel Level SD</b> This shutdown occurs when analog input Fuel Level is below shutdown level or binary input Fuel Level SD is closed longer than 10s.

#### 4.4 ECU Messages

```
10 SPN:190 19397.0
   FMI:30
```

ECU MESSAGE

#### ECU Message

Diagnostic messages are read and displayed in the history behind the ECU Warning symbol. For Standard J1939 SPN (Suspect Parameter Number) and FMI (Failure Mode Identifier) are shown.

Detail SPN/FMI code specification see in:

- SAE Truck and Bus Control and Communications Network Standards Manual, SAE HS-1939 Publication
- Or refer to corresponding engine manufacturer's ECU error codes list.

Complete list of text diagnostic messages for each ECU can be found in ComAp Electronic Engines Support manual.

## 5 SETUP

### 5.1 Accessing the setup mode

Ensure the engine is stopped and the controller is in Manual mode (green LED above button **AUTO** is turned off).

If you have not configured the custom initialization (init) screen then press and hold **STOP** button, then briefly press ▲ button and then **AUTO**.

If you have already created your own init screen then press and hold **STOP** button and then briefly press ▲, the custom init screen will appear, keep holding the **STOP** button. Then press ▼ to switch LCD to default init screen, and then press **AUTO**.

To move up and down in the setup menu use ▲ and ▼ buttons. Press **START** button to select or **STOP** button for exit.

### 5.2 Setpoints

Use ▲ and ▼ buttons to move or change value. **START** button to select setpoint or confirm changes and **STOP** button to go back.

 Basic setting		
Setpoint code	Setpoint name	
B01	Nominal Voltage Ph-N	80 – 480 V
B02	Nominal Voltage Ph-Ph	80 – 600 V
B03	Nominal Frequency	50 Hz (1), 60 Hz (2)
B04	Connection Type	Mono Phase (1), SplitPhase (2), 3Ph3Wire (3), 3Ph4Wire (4)
B05	Units Format	Metric unit format (1), US unit format (2)
B06	AMF Function	Disable (1), Enable (2)
B07	Zero Power Mode Delay	0-360 min
B08	Light Tower Mode	Disable (1), Enable (2)
B09	Nominal Current	1 - 1000 A
B10	CT Ratio	1 - 5000 A
B11	Nominal RPM	100-4000

## Outputs and inputs



### Engine parameters and protections

Setpoint code	Setpoint name	
E01	Prestart Time	0-600 s
E02	Maximum Cranking Time	0-60 s
E03	Cooling Time	0-3600 s
E04	Oil Pressure Shutdown	0-10 Bar
E05	Coolant Temperature Shutdown	0 - 150 °C
E06	Battery Undervoltage	8 - 40 V
E07	Warning Maintenance	0 - 10000 h
E08	Oil Pressure Starter Disengagement	Disable (1), Enable (2)
E09	Choke Time	0 - 3600 s
E10	Minimal Stabilization Time	1 - 300 s
E12	Cranking attempts	1 - 10
E15	Fuel Level Shutdown	0 - 20%



### Generator protections

Setpoint code	Setpoint name	
G01	Generator Overvoltage Shutdown	G02 - 200 %
G02	Generator Undervoltage Shutdown	0 - G01 %
G03	Generator Overfrequency Shutdown	G04 - 130 %
G04	Generator Underfrequency Shutdown	0 - G03 %
G05	Generator Short Circuit Shutdown	100 - 500 %
G06	Generator Short Circuit Delay	0 - 10,00 s



### AMF (Auto Mains Failure) setting

Setpoint code	Setpoint name	
A01	Emergency Start Delay	0 - 600 s
A02	Mains Return Delay	1 - 3600 s
A03	Mains Overvoltage	A04 - 150 %
A04	Mains Undervoltage	50 - A03
A05	Mains Overfrequency	A06 - 150 %
A06	Mains Underfrequency	50 - A05 %

Output code	Output source	Type	Terminal assignment
O00	Not Used	binary	T04 , T05, T06, T07, T08, T09
O01	Starter	binary	T04
O02	Fuel Solenoid	binary	T05, T06, T07, T08, T09
O03	Stop Solenoid	binary	T05, T06, T07, T08, T09
O04	Alarm	binary	T04, T05, T06, T07, T08, T09
O05	GCB Close/Open	binary	T04, T05, T06, T07, T08, T09
O06	MCB Close/Open	binary	T04, T05, T06, T07, T08, T09
O07	Ready To Load	binary	T04, T05, T06, T07, T08, T09
O08	Prestart	binary	T04, T05, T06, T07, T08, T09
O09	ECU Power Relay	binary	T04, T05, T06, T07, T08, T09
O10	Choke	binary	T04 , T05, T06, T07, T08, T09
O11	Glow Plugs	binary	T04 , T05, T06, T07, T08, T09

Outputs and inputs

Input code	Input source	Type	Terminal assignment
I00	Not Used	binary	T07, T11, T12, T13, T14, T15
I01	Emergency Stop	binary	T07, T11, T12, T13, T14, T15
I02	Remote Start/Stop	binary	T11
I03	Remote Start And Load	binary	T11
I04	Access Lock	binary	T07, T11, T12, T13, T14, T15
I05	AMF Blocked	binary	T07, T11, T12, T13, T14, T15
I06	MCB Feedback	binary	T07, T11, T12, T13, T14, T15
I07	GCB Feedback	binary	T07, T11, T12, T13, T14, T15
I10	External Warning 1	binary	T07, T11, T12, T13, T14, T15
I11	External Warning 2	binary	T07, T11, T12, T13, T14, T15
I12	External Warning 3	binary	T07, T11, T12, T13, T14, T15
I13	External Shutdown 1	binary	T07, T11, T12, T13, T14, T15
I14	External Shutdown 2	binary	T07, T11, T12, T13, T14, T15
I15	External Shutdown 3	binary	T07, T11, T12, T13, T14, T15
I20	Low Fuel Level	binary	T07, T11, T12, T13, T14, T15
I21	Fuel Level Analog	analog	T13, T14, T15
I22	Low Oil Pressure	binary	T07, T11, T12, T13, T14, T15
I23	Oil Pressure Analog	analog	T13, T14, T15
I24	High Coolant Temperature	binary	T07, T11, T12, T13, T14, T15
I25	Coolant Temperature Analog	analog	T13, T14, T15
I29	Fuel Level SD	binary	T07, T11, T12, T13, T14, T15



Normally Open Contact – output

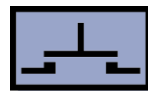

Normally Open Contact – input button



Normally Closed Contact – output



Normally Closed Contact – input button

User curves

	I21	I23	I25
	VDO Level %	VDO 5 Bar	VDO 40-120 °C
	Datcon Level %	VDO 10 Bar	VDO 50-150 °C
		Datcon 5 Bar	Datcon High °C
		Datcon 7 Bar	Datcon Low °C
		Datcon 10 Bar	
	NOT selected	NOT selected	NOT selected

To apply all changes return to the main setup menu and restart the controller by pressing the Stop button.











For ECU configuration use PC software NanoEdit. For more details see InteliNano AMF Reference Guide.



## 6 TECHNICAL DATA

Power supply range	6-36VDC
Power supply drop-out immunity	100ms
Power consumption	35 - 95 mA
Zero Power Mode consumption	52 - 344 $\mu$ A
Operating temperature	-20... 70°C
Operating humidity	95% non-condensing (IEC/EN 60068-2-30)
Protection degree (front panel)	IP65 - with GASKET 4x405 only IP50 - without gasket
Storage temperature	-30... 80°C
Binary inputs (up to 6)	
Input resistance	1,5 k $\Omega$
Closed contact voltage	<2V
Open contact voltage	>3,5V
Binary outputs (up to 6)	
Low current outputs (4)	500 mA
High current outputs (2)	6A - (long term) / 10A (short term) (L $\leq$ 500mH)
Total output current	10A – (long term) / 16A – (short term) (L $\leq$ 500mH)
Generator/Mains measurements	
Measurement inputs	1ph generator voltage, 1ph current, 3ph mains voltage
Measurement type	True RMS
Voltage range	480V Ph-Ph (277V Ph-N)
Max. measured voltage	340V Ph-N
Voltage accuracy	1 %
Frequency range	40-70 Hz
Frequency accuracy	1 %
Current range	0 - 5 A
Current accuracy	2% True RMS
Charging alternator preexcitation circuit	
Excitation current	100 mA
Charging fail threshold	80%
USB (device)	On the board
Type	CAN bus
Galvanic insulation	No
Baud rate	250 kbps
Bus length	max. 200m
Termination resistor	120 Ohm, built-in, jumper activated

## 7 PROCEDURE FOR HOUR/MAINTENANCE ALERT RESET

POSITION	BUTTON	DESCRIPTION
1		Turn off <b>AUTO</b> button
2		Press and hold <b>STOP</b> and press in sequence   <b>AUTO</b>
3		The screen show
4		Move on  with  and press <b>START</b>
5		Move to <i>E07</i> and press <b>START</b>
6		Set up hours for the next maintenance operation. (You have to set up hours following the instruction of user manual or the direction of the maintener)
7		Press <b>STOP</b> 3 times to exit



## BEDIENUNGS- UND WARTUNGSHANDBUCH

ÜBERSETZUNG DER ORIGINALEN ANLEITUNGEN – DEUTSCH

# COMAP InteliNano PLUS

- Unità controllo motore
- Engine control unit
- Protection moteur
- Motorschutz

- Unidad control motor
- Unidade de controlo do motor

Codice  
Code  
Code  
Codigo  
Kodezahl  
Código

MCM1K90F9003

Edizione  
Edition  
Édition  
Edición  
Ausgabe  
Edição

07.2019





<b>1. BEDIENERSCHNITTSTELLE</b> .....	<b>PAG.38</b>
<b>2. START UND STOPP DES MOTORS</b> .....	<b>PAG.39</b>
2.1 <i>MANUELLE MODALITÄT (IN AMF)</i> .....	PAG.39
2.2 <i>MANUELLE MODALITÄT (IN MRS)</i> .....	PAG.39
2.3 <i>AUTOMATISCHE MODALITÄT (IN AMF)</i> .....	PAG.39
2.4 <i>AUTOMATISCHE MODALITÄT (IN MRS)</i> .....	PAG.39
<b>3. SEITENAUFBAU</b> .....	<b>PAG.40</b>
3.1 <i>AUFBAU DER WICHTIGSTEN SEITEN (IN AMF)</i> .....	PAG.40
3.2 <i>AUFBAU DER WICHTIGSTEN SEITEN (IN MRS)</i> .....	PAG.40
<b>4. ALARME, EREIGNISSE UND VERWALTUNG DER AUFZEICHNUNGEN</b> .....	<b>PAG.41</b>
4.1 <i>EREIGNISSE</i> .....	PAG.42
4.2 <i>WARNHINWEISE</i> .....	PAG.43
4.2.1 <i>AKTIVER WARNHINWEIS</i> .....	PAG.43
4.2.2 <i>WARNHINWEIS NICHT AKTIV</i> .....	PAG.43
4.2.3 <i>MÖGLICHE WARNHINWEISE</i> .....	PAG.43
4.3 <i>ALARME</i> .....	PAG.44
4.3.1 <i>VORGANG ZUM HERUNTERFAHREN (SHUTDOWN)</i> .....	PAG.44
4.3.2 <i>AKTIVER ALARM (SHUTDOWN) NICHT BESTÄTIGT</i> .....	PAG.44
4.3.3 <i>AKTIVER ALARM (SHUTDOWN) BESTÄTIGT</i> .....	PAG.44
4.3.4 <i>NICHT AKTIVER ALARM (SHUTDOWN) NICHT BESTÄTIGT</i> .....	PAG.44
4.3.5 <i>NICHT AKTIVER ALARM (SHUTDOWN) BESTÄTIGT</i> .....	PAG.44
4.3.6 <i>MÖGLICHE ALARME (SHUTDOWN)</i> .....	PAG.45
4.4 <i>NACHRICHTEN ECU</i> .....	PAG.46
<b>5 EINSTELLUNG</b> .....	<b>PAG.46</b>
5.1 <i>ZUGRIFF AUF DIE EINSTELLUNGEN (KONFIGURATION UND PARAMETER)</i> .....	PAG.46
5.2 <i>EINSTELLUNGEN (PARAMETER)</i> .....	PAG.46
<b>6 TECHNISCHE DATEN</b> .....	<b>PAG.49</b>
<b>7 ALARM STUNDEN/WARTUNG RESET VORGANG</b> .....	<b>PAG.50</b>

## 1. BEDIENERSCHNITTSTELLE

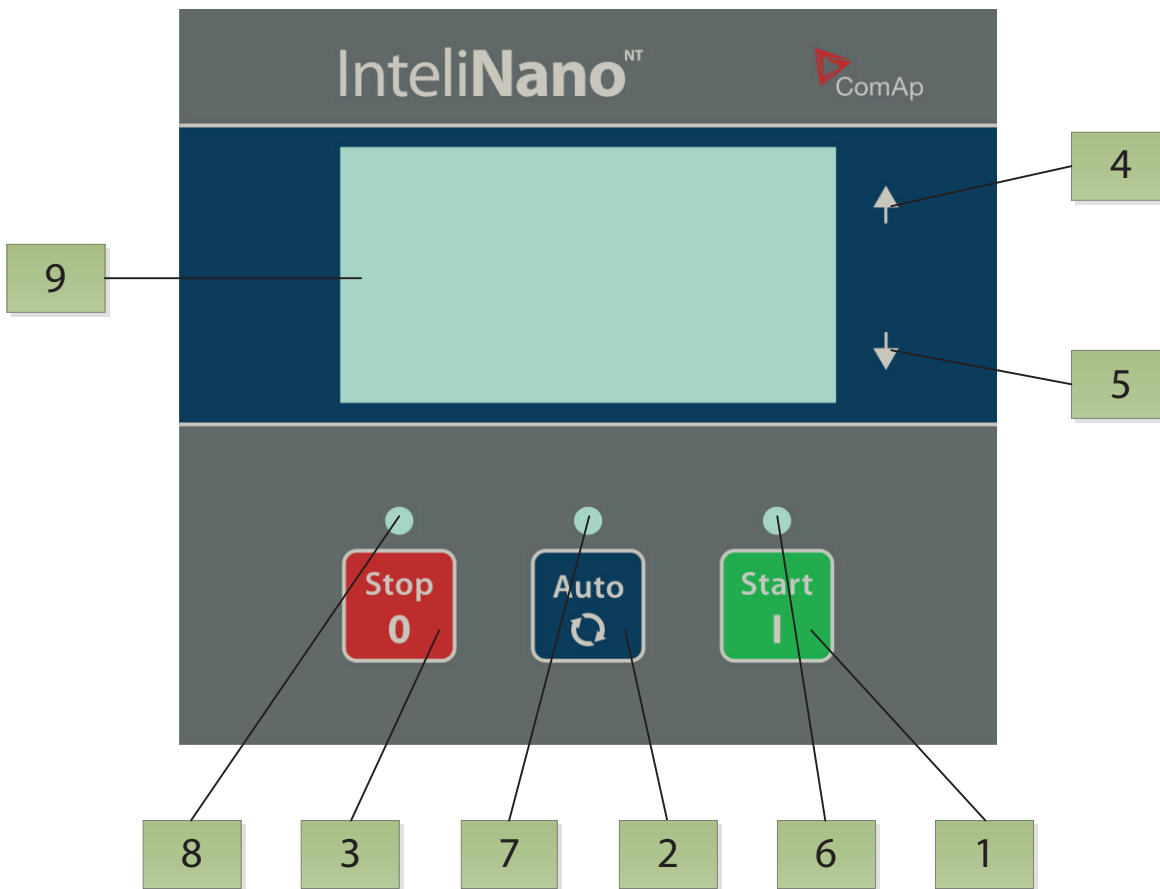

DEUTSCH

DEUTSCH

### STEUERTASTEN DES STROMAGGREGATS

POSITION	TASTE	BESCHREIBUNG
1		<b>START-DRUCKTASTE START</b> . Funktioniert nur der der Manuellen Modalität. Drücken Sie diese Drucktaste zum Anfangen der Startsequenz des Motors nur in der Manuellen Modalität. Diese Drucktaste wird auch zur Bestätigung der Änderungen während der Programmierung gebraucht.
2		<b>DRUCKTASTE AUTO AUTO</b> . Ist für den Übergang vom Manuellen zum Automatischen Betriebsmodus bestimmt.
3		<b>STOPP-DRUCKTASTE STOP</b> . Drücken Sie diese Drucktaste zum Anfangen der Stoppsequenz, wenn der Motor nur in der Manuellen Modalität in Bewegung ist. Diese Drucktaste wird auch zum Löschen der Änderungen während der Programmierung, für die Rückkehr, zum Austreten und zur Bestätigung eines Alarms benutzt.
4		<b>Drucktaste</b> Zum Bewegen nach oben oder Erhöhen der Werte.
5		<b>Drucktaste</b> zum Bewegen nach unten oder Senken der Werte.

### INDIKATOREN DES STROMERZEUGUNGSAGGREGATS

POSITION	BESCHREIBUNG DES INDIKATORS
6	<b>Motorfunktionsweise</b> Die grüne LED blinkt, wenn sich der Motor in der Start-, Kühlungs- oder Stopp-Phase befindet. Wenn die LED eingeschaltet ist, befindet sich der Motor in Bewegung und mit der Ladung verbunden oder dazu bereit, die Ladung entgegenzunehmen.
7	<b>Betriebsmodalität</b> Ist die LED eingeschaltet, befindet sich der Controller im AUTO-Modus. Ist sie ausgeschaltet, befindet sich der Controller im Manuellen Modus.
8	<b>Rote Alarm-LED</b> Die LED blinkt, wenn einer oder mehrere Warnhinweise (warning) oder Alarme (shutdown) aktiv sind. Die LED ist eingeschaltet, wenn der aktive Alarm bestätigt ist; der Motor kann nicht gestartet werden.
9	Grafik-Display in Schwarz/Weiß, 128x64 Pixel.

## 2. START UND STOPP DES MOTORS

### 2.1 Manuelle Modalität (in AMF)

Die grüne LED oberhalb der Drucktaste **AUTO** ist ausgeschaltet (der Controller ist im Manuellen Modus). Ist kein Alarm aktive (shutdown), ist es möglich, den Motor durch Drücken der **START**-Taste zu starten. Die grüne LED oberhalb der Drucktaste blinkt. Die LED blinkt während der Start-, Kühlungs- und Stopp-Phase. Ist der Motor bereits gestartet, hört die LED zu blinken auf und es bleibt ein festes Licht, der Generator ist dazu bereit, die Ladung aufzunehmen. Durch nochmaliges Drücken von **START** wird MCB geöffnet. Durch ein weiteres Drücken dieser Taste wird GCB geschlossen.

Drücken Sie die **STOP**-Taste zum Stoppen des Motors, Beim ersten Drücken wird GCB geöffnet, das anschließende Drücken schließt MCB. Durch nochmaliges Drücken der **STOP**-Taste beginnt die Kühlungssequenz und der Motorstopp. Ein weiteres Drücken stoppt den Motor sofort. Zur Beschleunigung der Übertragung der Ladung und des Motor-Stopps drücken Sie und die **STOP**-Taste und halten Sie sie so lange gedrückt, bis die Ladung übertragen und der Motor gestoppt ist.

### 2.2 Manuelle Modalität (in MRS)

Die grüne LED oberhalb der Drucktaste **AUTO** ist ausgeschaltet (der Controller ist im Manuellen Modus). Ist kein Alarm aktive (shutdown), ist es möglich, den Motor durch Drücken der **START**-Taste zu starten. Die grüne LED oberhalb der Drucktaste blinkt. Die LED blinkt während der Start-, Kühlungs- und Stopp-Phase. Ist der Motor bereits gestartet, hört die LED zu blinken auf und es bleibt ein festes Licht, der Generator ist dazu bereit, die Ladung aufzunehmen. Durch nochmaliges Drücken von **START** wird GCB geschlossen – nur wenn GCB konfiguriert ist.

Drücken Sie die **STOP**-Taste zum Stoppen des Motors, Das erste Drücken öffnet GCB, das anschließende beginnt die Kühlungs- und Stopp-Frequenz des Motors. Ein weiteres Drücken stoppt den Motor sofort. Zur Beschleunigung des Motor-Stopps drücken Sie STOPP und halten die Taste so lange gedrückt, bis der Motor Übertragung der Ladung und des Motor-Stopps drücken Sie und die **STOP**-Taste gestoppt ist.

### 2.3 Automatische Modalität (in AMF)

Die grüne LED oberhalb der Drucktaste **AUTO** ist eingeschaltet (der Controller ist im Auto-Modus). Durch das Drücken der **START**-Taste ist es nicht möglich, den Motor zu starten oder die Ladung zu übertragen. Der Controller startet den Motor automatisch, wenn alle Bedingungen für den Start und die Übertragung der Ladung erreicht sind. Der Motor kann in der Modalität Auto nicht durch Drücken der Drucktaste **STOP** gestoppt werden. Der Motor kann durch den Eingang der Schiene Remote Start/Stop oder Remote Start And Load gestartet werden

### 2.4 Automatische Modalität (in MRS)

Die grüne LED oberhalb der Drucktaste **AUTO** ist eingeschaltet (der Controller ist im Auto-Modus). Es ist nicht möglich, durch Drücken von **START** den Motor zu starten oder die Ladung zu verbinden. Der Controller startet den Motor automatisch, wenn alle Bedingungen für den Start und die Verbindung der Ladung erreicht sind. Der Motor kann in der Modalität Auto nicht durch Drücken der Drucktaste **STOP** gestoppt werden. Der Motor kann mittels Eingang Schiene Remote Start/Stop oder Remote Start And Load gestartet werden.

### 3. SEITENAUFBAU

Die visualisierten Informationen sind auf Seiten aufgebaut. Verwenden Sie die Drucktasten  und  um sich zu bewegen.

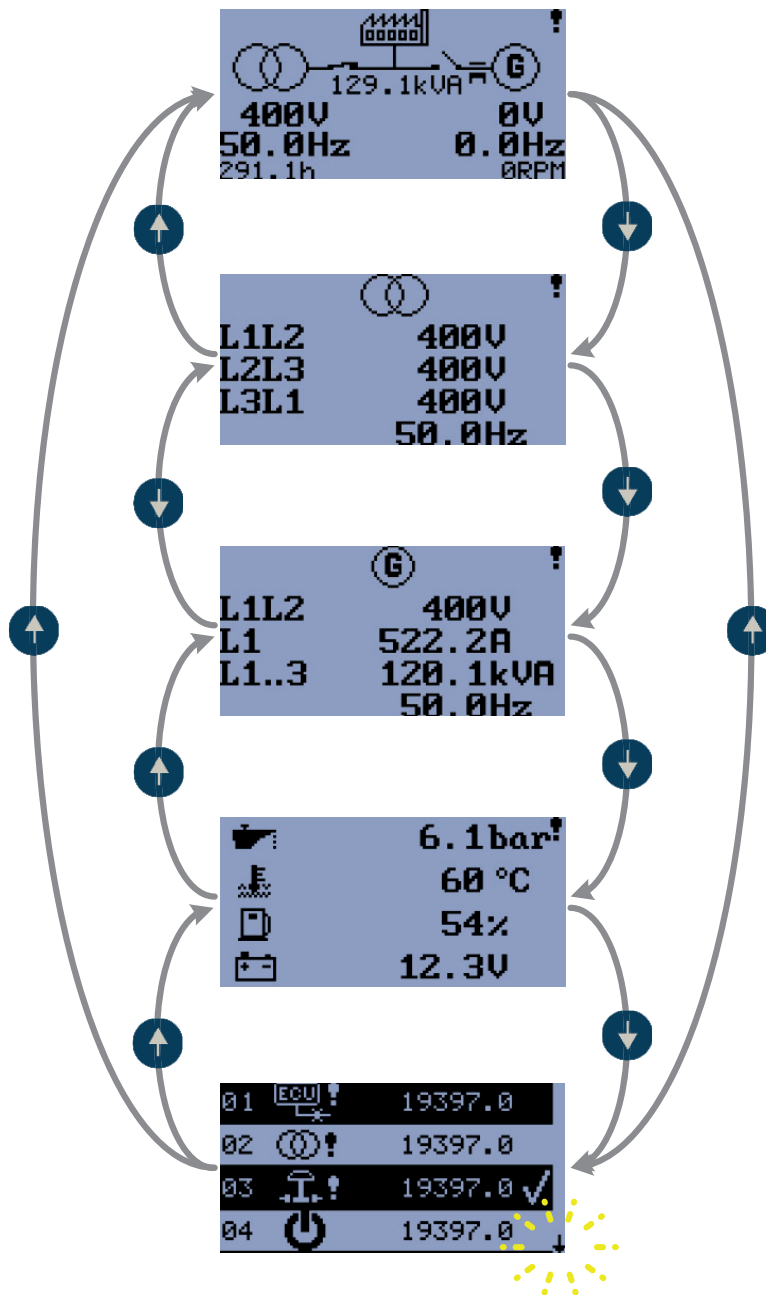

DEUTSCH

DEUTSCH

#### 3.1 Aufbau der wichtigsten Seiten (in AMF)

Die erste Seite enthält die Grundinformationen über die Maße von Spannung, Netzfrequenz und Generator. Es werden auch die Positionen (Zustände) von MCB und GCB, die Betriebsstunden, die durch den Generator gelieferte Leistung und die Anzahl Drehungen des Motors visualisiert. Bei Auftreten von jeglicher Alarm-Typ wird das allgemeine Warnsymbol an rechts oben in der Ecke des Display visualisiert.

Die zweite Seite enthält detaillierte Informationen über Spannungen und Netzfrequenz.

Die dritte Seite enthält detaillierte Informationen des Generators: Spannung, Strom, Leistung und Frequenz.

Die vierte Seite zeigt Informationen über den Motor – Öl Druck, Wassertemperatur, Kraftstoff-Füllstand und Batteriespannung auf. Die fünfte Seite zeigt die letzten Alarmergebnisse auf.

#### 3.2 Aufbau der wichtigsten Seiten (in MRS)

Die erste Seite enthält die Grundinformationen über die Maße von Spannung, Frequenz des Generators. Es wird auch die Position (Zustand) von GCB (nur wenn konfiguriert), die Betriebsstunden, die durch den Generator gelieferte Leistung und die Anzahl Drehungen des Motors visualisiert. Bei Auftreten von jeglichem Alarm-Typ wird das allgemeine Warnsymbol an rechts oben in der Ecke des Display visualisiert.

Die zweite Seite enthält detaillierte Informationen des Generators: Spannung, Strom, Leistung und Frequenz.

Die dritte Seite zeigt Informationen über den Motor – Öl Druck, Wassertemperatur, Kraftstoff-Füllstand und Batteriespannung auf. Die vierte Seite zeigt die letzten Alarmergebnisse auf.



#### 4. ALARME, EREIGNISSE UND VERWALTUNG DER AUFZEICHNUNGEN

Folgende Alarme und Aufzeichnungen sind verfügbar:

- Ereignisse
- Warnhinweise
- Alarme (shutdowns)
- Nachrichten ECU

Vier Aufzeichnungen könne gleichzeitig auf dem LCD-Bildschirm visualisiert werden. Die gesamte Kapazität beträgt 10 Aufzeichnungen, die Abbildung ist ein Beispiel dafür, wie die Historie organisiert ist. Die Seite in diesem Beispiel zeigt die letzten vier Ereignisse auf. Damit die anderen gespeicherten Aufzeichnungen gesehen werden können, muss 3 Sekunden gewartet werden, bis der Pfeil unten mit Blinken aufhört. Drücken Sie anschließend die Drucktaste ▼.

Drücken Sie für die Bestätigung der Alarme (shutdown) die Drucktaste STOPP.

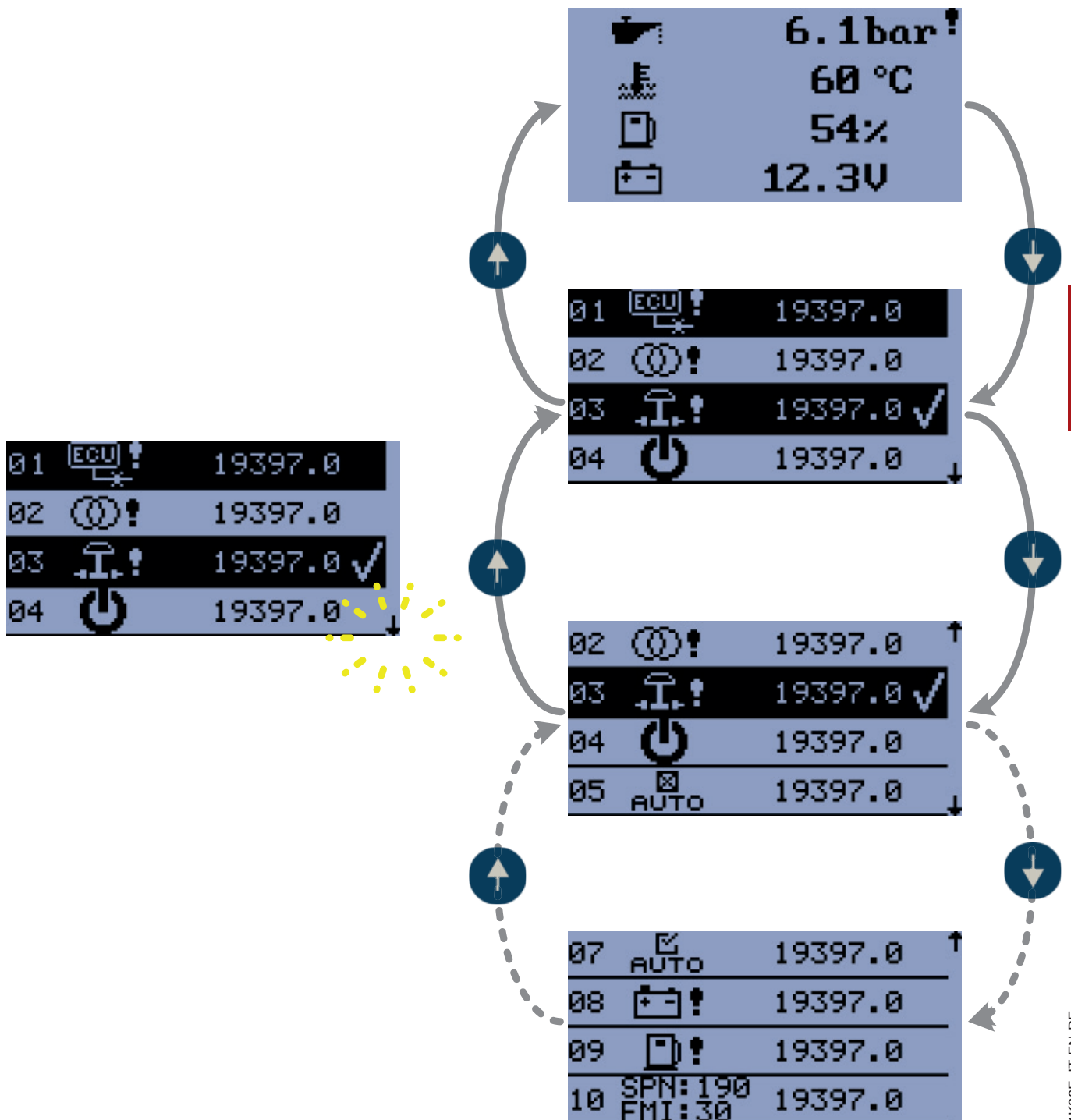

#### 4.1 Ereignisse

Jedes in der Tabelle aufgelistete Ereignis, das folgt, wird von den Betriebsstunden begleitet in der Historie gespeichert.



#### MÖGLICHE EREIGNISSE

	<b>Rückkehr Netz</b> Alle Netzparameter sind im Innern der eingestellten Felder.
	<b>Fehlendes Netz</b> Die Erfassung eines fehlenden Netzes hängt von den Sollwerteneinstellungen ab.
	<b>Manueller Start</b> Der Motor ist manuell gestartet worden, indem die <b>START</b> -Taste in der Manuellen Modalität gedrückt worden ist.
	<b>Ferngesteuerter Start</b> Der Motor ist mittels der Funktion des Endgeräts des Eingangs I02 Remote Start/Stop oder I03 Remote Start And Load gestartet worden. Der Controller befindet sich im Automatischen im Modus.
	<b>Start AMF</b> Der Motor ist aufgrund des fehlenden Netzes automatisch gestartet worden. Der Controller befindet sich im Automatischen im Modus
	<b>Manueller Stopp</b> Der Motor ist manuell gestoppt worden, indem die <b>STOP</b> -Taste in der Manuellen Modalität gedrückt worden ist.
	<b>Ferngesteuerter Stopp</b> Der Motor ist mittels der Funktion des Endgeräts des Eingangs I02 Remote Start/Stop oder I03 Remote Start And Load gestoppt worden. Der Controller befindet sich im Automatischen im Modus.
	<b>Stopp AMF</b> Der Motor ist aufgrund der Übertragung der Ladung zum Netz automatisch gestoppt worden. Der Controller befindet sich im Automatischen im Modus.
	<b>Auto ON</b> Die Modalität Auto ist aktiviert.
	<b>Auto OFF</b> Die Modalität Auto ist deaktiviert.
	<b>Versorgung</b> Der Controller ist eingeschaltet.
	<b>Funktion in Insel</b> Die Ladung wird vom Generator versorgt.

4.2 Warnhinweise

4.2.1 Aktiver Warnhinweis

Tritt ein Warnhinweis auf, schließt sich der Ausgang Alarm O04 und die rote LED oberhalb der Drucktaste Stopp blinkt. Das allgemeine Warnsymbol blinkt oben rechts in der Ecke des LCD-Bildschirms und das korrekte Symbol wird in der Historie mit den Betriebsstunden visualisiert. Ein aktiver Warnhinweis kann nicht bestätigt werden. Siehe Liste möglicher Warnhinweise



AKTIVER WARNHINWEIS - BATTERIE LEER

4.2.2 Warnhinweis nicht aktiv

Ist ein Warnhinweis nicht aktiv, öffnet sich der Ausgang Alarm O04, die rote LED oberhalb der Stopp-Taste hört zu blinken auf und das allgemeine Warnsymbol auf der Hauptseite schaltet aus



WARNHINWEIS NICHT AKTIV - BATTERIE LEER

4.2.3 Mögliche Warnhinweise

	<b>Wartung notwendig</b> Der Wartungseinsatz wird durch den Wert des Setpoint E07 Wartung bestimmt. Der Schutz wird aktiviert, wenn die Betriebsstunden des Motors diesen Wert erreichen.
	<b>Batteriespannung niedrig (Störung an der Batterieladung)</b> Dieser Warnhinweis tritt auf, wenn die Batteriespannung länger als 30 Sekunden tiefer ist als die vorbestimmte Grenze der Unterspannung der Batterie ist. Dieser Warnhinweis erscheint auch im Falle einer Störung des Wechselstromgenerators der Batterieladung.
	<b>Niedriger Kraftstoffstand</b> Dieser Warnhinweis tritt auf, wenn der analoge Eingang Kraftstoff-Füllstand niedriger ist als 20% oder der Eingang Kraftstoff-Füllstand für mehr als 10 Sekunden geschlossen bleibt.
	<b>Externe Warnung 1</b> Dieser Warnhinweis tritt auf, wenn der Eingang External Warning aktiviert ist.
	<b>Externe Warnung 2</b> Dieser Warnhinweis tritt auf, wenn der Eingang External Warning 2 aktiviert ist.
	<b>Externe Warnung 3</b> Dieser Warnhinweis tritt auf, wenn der Eingang External Warning 3 aktiv ist.
	<b>ECU Verbindungsfehler</b> Dieser Warnhinweis wird aktiviert, wenn die ECU, (wenn konfiguriert) nicht kommuniziert und alle Werte der ECU auf dem Display mit ##### visualisiert werden.
	<b>Netzschalter Fehler</b> Aktion des Netzzählers MCB fehlgeschlagen
	<b>Phasensequenz des NETZES Gegenuhrzeigersinn (CCW) Drehfeld Falsch</b> Falsche Phasensequenz des NETZES (Gegenuhrzeigersinn CCW).

## 4.3 Alarme

### 4.3.1 Vorgang zum Herunterfahren (shutdown)

Der Controller InteliNano Plus öffnet die Ausgänge O05 GCB Close/Open, O01 Starter, O08 Prestart und Fuel Solenoid und schließt O03 Stop Solenoid, um den Motor sofort zu stoppen. Der Ausgang O04 Alarm wird geschlossen. Aktive oder nicht bestätigte Schutzvorrichtungen deaktivieren den Start.

### 4.3.2 Aktiver Alarm (shutdown) nicht bestätigt

Wenn sich ein Stopp ereignet, beginnt der Ausschaltvorgang, die rote LED oberhalb der Stopp-Taste blinkt, das allgemeine Symbol für Vorsicht blinkt oben rechts in der Ecke des LCD-Bildschirms und das korrekte Symbol für die Ausschaltung wird in der Historie mit den Betriebsstunden visualisiert. Die Aufzeichnung in der Historie ist negativ, siehe Abbildung. Siehe Liste möglicher Alarme (shutdown). Drücken Sie für die Bestätigung eines Alarms (shutdown) die Drucktaste Stopp.



AKTIVER ALARM (SHUTDOWN) NICHT BESTÄTIGT - NOT-STOPP

### 4.3.3 Aktiver Alarm (shutdown) bestätigt

Wenn ein aktiver Stopp bestätigt wird, hört die rote LED oberhalb der Stopp-Taste zu blinken auf. Die Aufzeichnung in der Historie bleibt negativ mit dem Bestätigungssymbol am Schluss. Der Ausgang O04 Alarm ist geöffnet.



AKTIVER ALARM (SHUTDOWN) BESTÄTIGT - NOT-STOPP

### 4.3.4 Nicht aktiver Alarm (shutdown) nicht bestätigt

Der Ausgang O04 ist geschlossen, die rote LED oberhalb der Stopp-Taste blinkt, das allgemeine Symbol für Vorsicht blinkt oben rechts in der Ecke des LCD-Bildschirms und das korrekte Symbol für die Vorsicht wird in der Historie mit den Betriebsstunden visualisiert. Siehe Liste möglicher Alarme (shutdown). Drücken Sie für die Bestätigung eines Alarms (shutdown) die Stopp-Taste



NICHT AKTIVER ALARM (SHUTDOWN) NICHT BESTÄTIGT - NOT-STOPP

















### 4.3.5 Nicht aktiver Alarm (shutdown) bestätigt





Der Ausgang O04 Alarm ist geöffnet. Es ist möglich, den Motor zu starten, wenn alle Alarme (shutdowns) nicht aktiv und bestätigt sind.



NICHT AKTIVER ALARM (SHUTDOWN) BESTÄTIGT - NOT-STOPP

## 4.3.6 Mögliche Alarme (shutdown)

	<b>Not-Stopp</b> Der Eingang Schiene Emergency Stopp ist aktiviert worden.
	<b>Übergeschwindigkeit</b> Der Schutz wird aktiv, wenn die Geschwindigkeit um 115% größer ist als die Nenngeschwindigkeit des Motors, welche von der Frequenz des Generators abgeleitet ist.
	<b>Untergeschwindigkeit</b> Niedrige Motordrehzahl. Dieser Alarm wird ausgegeben, wenn das Stromerzeugungsaggregat läuft und dann von selbst stoppt, das heißt, die Drehzahl sinkt unter die Nennmotordrehzahl. Der Alarm Untergeschwindigkeit beginnt 5 Sekunden nach dem Start des Generators bewertet zu werden und wird für die gesamte Zeit, in der der Ausgang Fuel Solenoid geschlossen ist, bewertet.
	<b>Niedriger Öl-Druck</b> Der Motor hält an, wenn der Öl-Druck sinkt oder niedriger ist als 1 bar oder der Eingang Schiene I22 Low Oil Pressure aktiv ist.
	<b>Hohe Temperatur der Kühlungsflüssigkeit</b> Der Motor hält an, wenn die Temperatur der Kühlungsflüssigkeit den Grenzwert von Coolant Temperature Shutdown überschreitet.
	<b>Externer Alarm 1</b>
	<b>Externer Alarm 2</b>
	<b>Allarme esterno 3</b>
	<b>Fehlschlagen von GCB.</b> Aktion des Generatorzählers GCB fehlgeschlagen.
	<b>Überspannung Generator</b> Der Generator hält an, wenn die Ausgangsspannung den in G01 Generator Overvoltage Shutdown eingestellte Grenzwert überschreitet.
	<b>Unterspannung Generator</b> Der Generator hält an, wenn die Ausgangsspannung unter den in G02 Generator Underoltage Shutdown eingestellten Grenzwert sinkt.
	<b>Überfrequenz Generator</b> Die Frequenz des Generators ist außerhalb der Grenzen, welche in den Einstellungen G03 Generator Overfrequency Shutdown and G04 Generator Underfrequency Shutdown gegeben sind.
	<b>Unterfrequenz Generator</b> Die Frequenz des Generators ist außerhalb der Grenzen, welche in den Einstellungen G03 Generator Overfrequency Shutdown and G04 Generator Underfrequency Shutdown gegeben sind.
	<b>Phasensequenz des GENERATORS Gegenuhrzeigersinn (CCW)</b> Falsche Phasensequenz des GENERATORS (Gegenuhrzeigersinn CCW).
	<b>Start fehlgeschlagen</b> Fehlender Start des Generators.
	<b>Fehlender Stopp</b> Fehlender Stopp des Generators

	<b>Batterie leer</b> Verliert der Controller die Versorgung während der Start-Sequenz aufgrund der schlechten Bedingungen der Batterie, versucht er nicht, den Motor neu zu starten und aktiviert diesen Schutz.
	<b>Automatische Erfassung der Spannung</b> Wenn Sie für die Einstellung von B04 "Connection Type" die automatische Erfassung benutzen, und die gemessene Spannung des Generators nicht mit den Werten übereinstimmt, welche für die besondere Anschlussart vorbestimmt worden sind, wird ein Alarm visualisiert.
	<b>Kurzschluss Generator</b> Wenn der Generatorstrom die voreingestellte Stromgrenze überschreitet.
	<b>Alarm (shutdown) niedriger Kraftstoff-Füllstand</b> Dieser Stopp tritt auf, wenn der analoge Eingang Kraftstoff-Füllstand niedriger ist als das voreingestellte Stopp-Niveau oder wenn der Eingang Schiene Fuel Level SD länger als 10 Sekunden geschlossen bleibt.

#### 4.4 Nachrichten ECU

```
10 SPN:190 19397.0
   FMI:30
```

NACHRICHTEN ECU

##### Nachricht ECU

Die Diagnostik-Nachrichten werden in der Historie hinter dem ECU-Warnhinweis-Symbol gelesen und visualisiert. Es werden die Nachrichten für die Standard J1939 SPN (Suspect Parameter Number) und FMI (Failure Mode Identifier) gezeigt.

Für die besonderen Spezifikationen der Codes SPN / FMI siehe in:

- SAE Truck and Bus Control and Communications Network Standards Manual, Veröffentlichung SAE HS-1939,
- Oder Sie beziehen sich auf die entsprechende Code-Liste der ECU-Fehler des Motorherstellers.

Eine komplette Liste der Textnachrichten der Diagnose für jede ECU kann im ComAp elektronische Motoren Handbuch zur Unterstützung gefunden werden.

## 5 EINSTELLUNG

### 5.1 Zugriff auf die Einstellungen (Konfiguration und Parameter)

Stellen Sie sicher das das Aggregat nicht in Betrieb ist und sich die Steuerung im MANUELL Modus befindet. (Grüne LED oberhalb der **AUTO** Taste leuchtet NICHT).

Wurde der Willkommensbildschirm noch nicht konfiguriert drücken Sie die **STOP** , Taste und halten diese gedrückt während Sie nacheinander die Tasten **▲** und **AUTO** drücken um auf die Konfigurationsebene zu gelangen.

**Wurde der Willkommensbildschirm bereits eingerichtet** drücken Sie die **STOP** Taste und halten diese gedrückt während Sie nacheinander die Tasten **▲** und **▼** und **AUTO** drücken um auf die Konfigurationsebene zu gelangen.

Um im Menü zu Blättern und die Symbole auszuwählen benutzen Sie die **▲** und **▼**Tasten. Drücken Sie **START** zum Bestätigen (Enter) oder **STOP** um die Auswahl zu verlassen (Escape).

### 5.2 Einstellungen (Parameter)

Um in den Parametern zu Blättern und die Symbole auszuwählen benutzen Sie die **▲** und **▼** Tasten. Drücken Sie **START** zum Bestätigen (Enter) oder **STOP** um die Auswahl zu verlassen (Escape).

 <b>Grundeinstellungen</b>		
Code	Funktion	
B01	Nennspannung Ph-N	80 – 480 V
B02	Nennspannung Ph-Ph	80 – 600 V
B03	Nennfrequenz	50 Hz (1), 60 Hz (2)
B04	Anschluss Typ	Mono Phase (1), SplitPhase (2), 3Ph3Wire (3), 3Ph4Wire (4)
B05	Einheiten	Metrisch (1), US format (2)
B06	AMF Funktion	Aus (1), Ein (2)
B07	Display Aus nach	0-360 min
B08	Lichtmast Modus	Aus (1), Ein (2)
B09	Strombereich	1 - 1000 A
B10	Stromwandlerverhältnis	1 - 5000 A
B11	Nenn Drehzahl	100-4000

## Ein- und Ausgänge



### Motoreinstellungen

Code	Funktion	
E01	Startvorbereitungs-Zeit	0-600 s
E02	Maximale Anlassdauer	0-60 s
E03	Abkühlung	0-3600 s
E04	Öldruckmangel-Abschaltung	0-10 Bar
E05	Kühlwassertemperatur-Abschaltung	0 - 150 °C
E06	Batterie-Unterspannungsschwelle	8 - 40 V
E07	Wartungsaufruf	0 - 10000 h
E08	Anlasser ausrücken über Öldruck	Aus (1), Ein (2)
E09	Choke-Zeit	0 - 3600 s
E10	Mindest Motor Stabilisierungs-Zeit	1 - 300 s
E12	(TT) Startversuche	1 - 10
E15	Kraftstoffstand-Abschaltung	0 - 20%



### Generatoreinstellungen

Code	Funktion	
G01	Überspannungsabschaltung	G02 - 200 %
G02	Unterspannungsabschaltung	0 - G01 %
G03	Überfrequenzabschaltung	G04 - 130 %
G04	Unterfrequenzabschaltung	0 - G03 %
G05	Generator Kurzschlussleistung	100 - 500 %
G06	Generator Kurzschlussverzögerung	0 - 10,00 s



### Notstromautomatik Einstellungen

Code	Funktion	
A01	Verzögerung Netzausfallerkennung	0 - 600 s
A02	Verzögerung Netzurückkehr	1 - 3600 s
A03	Netz Überspannung	A04 - 150 %
A04	Netz Unterspannung	50 - A03
A05	Netz Überfrequenz	A06 - 150 %
A06	Netz Unterfrequenz	50 - A05 %

Code	Ausgangs-Funktion	Typ	mögliche Terminal Zuordnung
O00	Keine Funktion	binär	T04 , T05, T06, T07, T08, T09
O01	Anlasser	binär	T04
O02	Betriebsmagnet	binär	T05, T06, T07, T08, T09
O03	Stoppmagnet	binär	T05, T06, T07, T08, T09
O04	Alarm	binär	T04, T05, T06, T07, T08, T09
O05	Generatorschalter Ein/Aus	binär	T04, T05, T06, T07, T08, T09
O06	Netzschalter Ein/Aus	binär	T04, T05, T06, T07, T08, T09
O07	Bereit für Lastübernahme	binär	T04, T05, T06, T07, T08, T09
O08	Startvorbereitung	binär	T04, T05, T06, T07, T08, T09
O09	ECU-Spannungsversorgung	binär	T04, T05, T06, T07, T08, T09
O10	Choke	binär	T04 , T05, T06, T07, T08, T09
O11	Glühkerzen	binär	T04 , T05, T06, T07, T08, T09

## Ein- und Ausgänge

Code	Ausgangs-Funktion	Typ	mögliche Terminal Zuordnung
I00	Keine Funktion	binär	T07, T11, T12, T13, T14, T15
I01	NOT-Aus	binär	T07, T11, T12, T13, T14, T15
I02	Fern Start/Stop	binär	T11
I03	Fern-Start und Lastübernahme	binär	T11
I04	Zugriff (Frontpanel) blockieren	binär	T07, T11, T12, T13, T14, T15
I05	Notstromautomatik blockieren	binär	T07, T11, T12, T13, T14, T15
I06	Netzschalter Rückmeldung	binär	T07, T11, T12, T13, T14, T15
I07	Generatorschalter Rückmeldung	binär	T07, T11, T12, T13, T14, T15
I10	Externe Warnung 1	binär	T07, T11, T12, T13, T14, T15
I11	Externe Warnung 2	binär	T07, T11, T12, T13, T14, T15
I12	Externe Warnung 3	binär	T07, T11, T12, T13, T14, T15
I13	Externer Not-Halt 1	binär	T07, T11, T12, T13, T14, T15
I14	Externer Not-Halt 2	binär	T07, T11, T12, T13, T14, T15
I15	Externer Not-Halt 3	binär	T07, T11, T12, T13, T14, T15
I20	Niedriger Kraftstoffstand- Kontakt Warnung	binär	T07, T11, T12, T13, T14, T15
I21	Analogwert Kraftstoffstand	analog	T13, T14, T15
I22	Öldruck-Schalter	binär	T07, T11, T12, T13, T14, T15
I23	Analogwert Öldruck	analog	T13, T14, T15
I24	Kühlmitteltemperatur-Schalter	binär	T07, T11, T12, T13, T14, T15
I25	Analogwert Kühlmitteltemperatur	analog	T13, T14, T15
I29	Kraftstoffmangel-Abstellung	binär	T07, T11, T12, T13, T14, T15



NO Kontakt (Ausgänge)



NO Kontakt – (Eingänge taste)

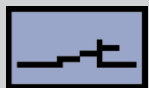

NC Kontakt – (Ausgänge)

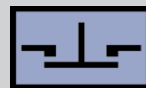

NC Kontakt – (Eingänge taste)

### Widerstandskurven

	I21	I23	I25
	VDO Analogwert %	VDO 5 Bar	VDO 40-120 °C
	Datcon Analogwert %	VDO 10 Bar	VDO 50-150 °C
		Datcon 5 Bar	Datcon High °C
		Datcon 7 Bar	Datcon Low °C
		Datcon 10 Bar	
	Nicht benutzt	Nicht benutzt	Nicht benutzt

Um die Änderungen zu speichern und zum Betriebsmodus zurück zu kehren drücken Sie solange mehrmals die Stop -Taste bis die Steuerung einen Neustart durchführt.











Zur Einstellung der Motorsteuergeräte (ECU) benutzen Sie bitte die Konfigurations-Software NanoEdit. Für weitere Informationen steht Ihnen das **InteliNano Referenz-Handbuch** zur Verfügung



## 6 TECHNISCHE DATEN

Eingangsspannungsbereich	6-36VDC
Überbrückungszeit	100ms
Stromaufnahme im Betrieb	35 - 95 mA
Stromaufnahme im Ruhe-Modus	52 - 344 $\mu$ A
Betriebstemperatur	-20... 70°C
Max. Luftfeuchte	95% nicht kondensierend (IEC/EN 60068-2-30)
Schutzart (Front)	IP65 - mit Dichtung 4x405 IP50 - ohne Dichtung
Lagertemperatur	-30... 80°C
Binary inputs (up to 6)	
Input resistance	1,5 k $\Omega$
Closed contact voltage	<2V
Open contact voltage	>3,5V
Binäre Ausgänge (bis zu 6)	
Niederstrom-Ausgänge (4)	500 mA
Hochstrom-Ausgänge (2)	6A - (Dauernd) / 10A (Kurzzzeitig) (L $\leq$ 500mH)
Zulässiger Gesamtstrom	10A – (Dauernd)) / 16A – (Kurzzzeitig) (L $\leq$ 500mH)
Generator / Netz Messungen	
Messeingang AC	1ph Gen.-Spannung, 1ph Gen-Strom, 3ph Netz
Messtechnologie	True RMS
Spannungsbereich bis	480V Ph-Ph (277V Ph-N)
Max. zulässige Spannung	340V Ph-N
Messgenauigkeit Spannung	1 %
Frequenzbereich	40-70 Hz
Messgenauigkeit Frequenz	1 %
Strombereich	0 - 5 A
Messgenauigkeit Strom	2% True RMS
Lichtmaschinen-Erregung und Überwachung	
Erregerstrom max.	100 mA
Fehler Lichtmaschine (Eingang)	80%
USB (Vorrichtung)	an der Tafel
Typ	CAN bus
Galvanische Trennung	keine
Datenübertragungsgeschwindigkeit	250 kbps
Buslänge	max. 200m
Terminierungswiderstand	120 Ohm, eingebaut, Überbrückung aktiviert

## 7 ALARM STUNDEN/WARTUNG RESET VORGANG

POSIZION	TASTE	REFERENZLISTE
1		Taste <b>AUTO</b> ausschalten
2		<b>STOP</b> gedrückt halten und nacheinander   <b>AUTO</b> drücken
3		Erscheint der Bildschirminhalt
4		Bewegen Sie sich mit  zu  und drücken <b>START</b>
5		Bis zu <i>E07</i> bewegen und <b>START</b> drücken
6		Die Stunden nächster Wartungsarbeiten einstellen (die Stunden einstellen nach dem Benutzungs- und Wartungshandbuch des Motors oder der Hinweis des Servicetechnikers)
7		Dreimal <b>STOP</b> drücken zum Enden



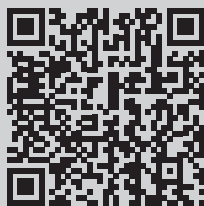

<https://goo.gl/MbFOV9>

**MOSA**

**MOSA div. della BCS S.p.A.**

Viale Europa, 59 20090 Cusago (Milano) Italy

Tel. +39 - 0290352.1 Fax +39 - 0290390466 [www.mosa.it](http://www.mosa.it)

