

Bedienungs- und Montageanleitung
Instructions d'emploi et de montage
Istruzioni d'uso e montaggio
Operating- and installation
instructions

JRG Sanipex MT
4800.000/.050
d16/20/26

Montagekoffer	D 1 – 12
Coffret de montage	F 13 – 27
Valigetta di montaggio	I 29 – 43
Fitter's toolkit	E 45 – 59



+GF+

JRG

Bedienungs- und Montageanleitung

Bitte lesen Sie die vorliegende Bedienungs- und Montageanleitung vor dem Gebrauch der Werkzeuge aufmerksam durch.

Der Montagevorgang gilt sinngemäss auch für JRG Sanipex PE-X Rohre.

Die eingesetzten Symbole bedeuten:



Warnung

Dieses Symbol weist auf eine Information hin, deren Nichtbeachtung zu umfangreichen Sachschäden führen kann. Die Sicherheitshinweise sind zu beachten.



Hinweis

Dieses Symbol weist auf eine Information hin, die wichtige Angaben hinsichtlich der Verwendung enthält. Das Nichtbefolgen kann zu Störungen führen.

Die Bedienungs- und Montageanleitung ist Bestandteil der **JRG Sanipex MT** Montagewerkzeuge. Sie ist im Montagekoffer aufzubewahren.

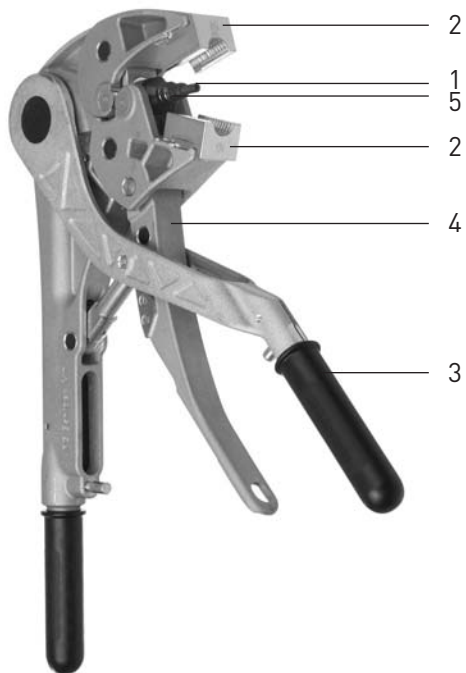

Aufbau der JRG Sanipex MT Aufweitzange

- 1 Führungsstift
- 2 Klemmbacken
- 3 Arbeitshebel
- 4 Spannhebel
- 5 Aufweitdorn

Montagekoffer d16+20+26, JRG Nr. 4800.000/.050

Im Montagekoffer 4828.000 sind enthalten:

4804.000	Aufweitzange
4832.016	Ratschen-Drehmomentschlüssel 16
4832.020	Ratschen-Drehmomentschlüssel 20
4832.026	Ratschen-Drehmomentschlüssel 26
4834.016	Konterschlüssel 16
4834.020	Konterschlüssel 20
4834.026	Konterschlüssel 26
4806.016	Handbiegeschablone 16
4806.020	Handbiegeschablone 20
4806.026	Handbiegeschablone 26 (optional)
4837.000	Kombischere 16/20
4836.000	Rohrabschneider
4838.000	Markierstift
5777.000	Richthülse 1/2"
5790.008	Dosen-Montageschlüssel
4804.016	Klemmbacken 16
4804.020	Klemmbacken 20
4804.026	Klemmbacken 26
4804.116	Aufweitdorn 16 für MT Rohr
4804.120	Aufweitdorn 20 für MT Rohr
4804.126	Aufweitdorn 26 für MT Rohr
4804.216	Aufweitdorn 16 für PE-X Rohr
4804.220	Aufweitdorn 20 für PE-X Rohr
09 458 55	Bedienungs- und Montageanleitung

Einleitung

Die JRG Sanipex MT Montagewerkzeuge dienen ausschliesslich der Montage des JRG Sanipex MT Installationssystems und bedürfen, bei bestimmungsgemäsem Gebrauch, keiner weiteren Wartung.

Es dürfen nur JRG Sanipex MT Systemkomponenten mit diesem Werkzeug verarbeitet werden.

Die Werkzeuge dürfen nicht zweckentfremdet werden.

An den JRG Sanipex MT Werkzeugen dürfen keine Reparaturen oder Änderungen irgendwelcher Art vorgenommen werden.

Folgende Rohre können mit der JRG Sanipex MT Aufweitzange (JRG Nr. 4800.000) aufgeweitet werden:

4600.016 – .026	JRG Sanipex MT Rohr	d16–d26	schwarz, in Stangen, 5 m
4600.316 – .326	JRG Sanipex MT Rohr	d16–d26	schwarz, in Stangen, 3 m
4602.016 – .020	JRG Sanipex MT Rohr	d16–d20	weiss, in Ringen, mit Schutzrohr
4604.016 – .026	JRG Sanipex MT Rohr	d16–d26	weiss, in Ringen
4606.016 – .026	JRG Sanipex MT Rohr	d16–d26	weiss, in Ringen, isoliert
5706.016/.020	JRG Sanipex Rohr	d16/d20	weiss, in Ringen, mit Schutzrohr
5707.016/.020	JRG Sanipex Rohr	d16/d20	weiss, in Ringen
5716.016/.020	JRG Sanipex Rohr	d16/d20	blau, in Ringen, mit Schutzrohr
5717.016/.020	JRG Sanipex Rohr	d16/d20	blau, in Ringen

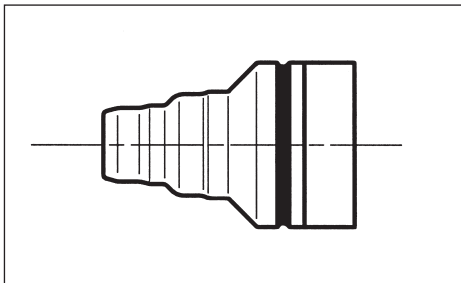

Auswählen der Aufweitdorne

Für JRG Sanipex MT Rohre $d16 \times 2,25$
Aufweitdorn mit einer Rille, schwarz

Für JRG Sanipex MT Rohre $d20 \times 2,5$
Aufweitdorn mit einer Rille, blau

Für JRG Sanipex MT Rohre $d26 \times 3,0$
Aufweitdorn mit einer Rille, rot

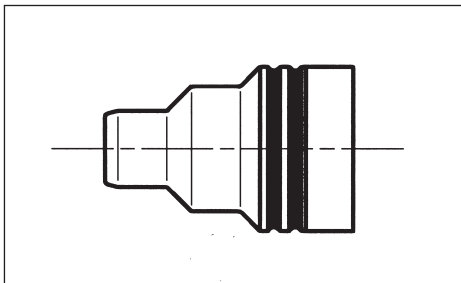

Für JRG Sanipex PE-Xa und PE-Xc Rohre $d16 \times 2,2$
Aufweitdorn mit zwei Rillen, schwarz

Für JRG Sanipex PE-Xa und PE-Xc Rohre $d20 \times 2,8$
Aufweitdorn mit zwei Rillen, blau

Wechseln der Aufweitdorne



Arbeitshebel (3) etwas schliessen und in dieser Position festhalten. Dadurch wird der Haltemechanismus entlastet.

Durch drücken des Führungsstiftes (1) wird der Aufweitdorn (5) freigegeben. Arbeitshebel unverändert halten.

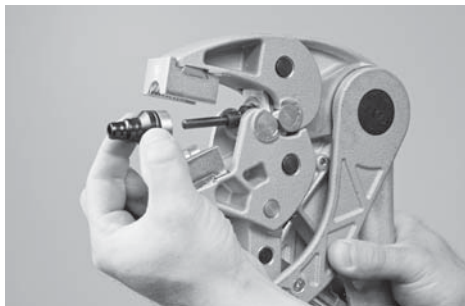

Gewünschter Aufweitdorn (5) über den Führungsstift (1) schieben. Führungsstift (1) drücken und den Aufweitdorn (5) bis an den Anschlag schieben.

Der Wechsel des Aufweitdorns (5) ist abgeschlossen, wenn der Führungsstift (1) losgelassen wird.

Wechseln der Klemmbacken

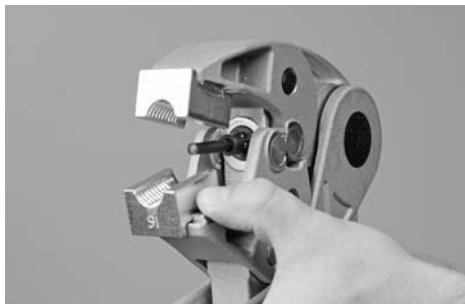

Klemmbacken (2) seitlich aus der Klemmbackenführung hinausschieben und die gewünschten Klemmbacken einschieben.

Montagevorgang



JRG Sanipex MT Rohr d16 oder d20 mit der Kombischere (JRG Nr. 4837) und d26 mit dem Rohrabschneider (JRG Nr. 4836) auf die gewünschte Länge ablängen.



Nach dem Aufschieben der Überwurfmutter das JRG Sanipex MT Rohr bis zum Anschlag über den Aufweitdorn in die Aufweitzange einführen und Spannhebel (4) schliessen.



Hinweis **Richtiger Aufweitdorn**

Beachten Sie, dass der dem Rohr entsprechende Aufweitdorn (5) sowie die der Dimension entsprechenden Klemmbacken (2) eingesetzt sind.



Aufweitvorgang durch Schliessen des Arbeitshebels (3) durchführen.

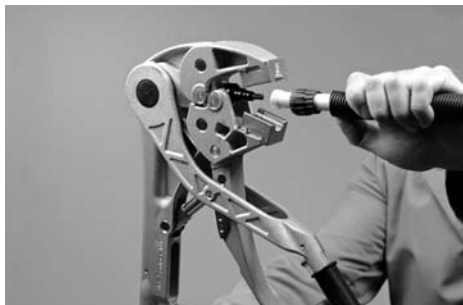

Arbeitshebel (3) öffnen und das aufgebördelte Rohrende wird freigegeben.



Hinweis
Aufweiten von JRG Sanipex
Rohren aus PE-X

Nach dem Aufweiten von flexiblen JRG Sanipex PE-X Rohren muss die Verbindung umgehend fertig erstellt werden.

Klemmverbinder richtig

Kontrolle Aufweitvorgang.
Der O-Ring am Fitting muss durch den
Rohrbördel vollständig verdeckt sein.

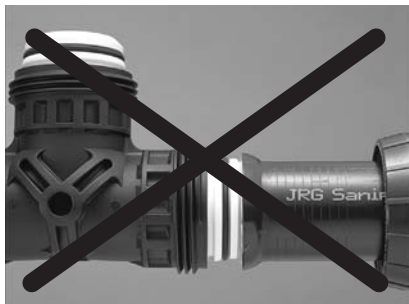

Warnung
Nicht korrekt ausgebildete Rohrbördel
Dürfen nicht nachgebördelt werden!

Klemmverbinder falsch



Aufgebördeltes JRG Sanipex MT Rohr auf den JRG Sanipex MT Fitting stecken. Überwurfmutter handsatt anziehen.



Überwurfmutter mit dem Ratschen-Drehmomentschlüssel (JRG Nr. 4832) anziehen. Zum Gegenhalten Richthülse (JRG Nr. 5777) oder Konterschlüssel (JRG Nr. 4834) verwenden.

**Warnung****Funktionsstörungen an Ratschen-Drehmomentschlüssel**

Bei allfälligen Funktionsstörungen oder bei Beschädigungen empfehlen wir den JRG Sanipex MT Ratschen-Drehmomentschlüssel im Austausch zu ersetzen.

**Warnung****Reparatur an Ratschen-Drehmomentschlüssel**

An JRG Sanipex MT Ratschen-Drehmomentschlüsseln dürfen keine Reparaturen vorgenommen werden.

**Hinweis****Ratschen-Drehmomentschlüssel**

Die JRG Sanipex MT Ratschen-Drehmomentschlüssel dienen ausschliesslich zum Anziehen von JRG Sanipex MT Bördelklemmverbindern.

Die entsprechenden Drehmomente sind vom Werk fest eingestellt und bedürfen, bei bestimmungsgemäsem Gebrauch, keiner weiteren Wartung.

Auswechseln des Schneiderades

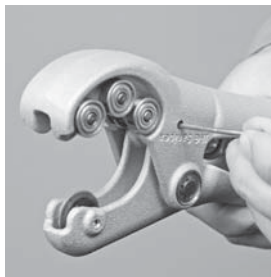

Rohrabschneider durch betätigen des Hebels vollständig öffnen. Arretierstift (z.B. Nagel Ø 3 mm) durch die Bohrung schieben. Dadurch bleibt der Rohrabschneider gesichert offen.



Mit einem Schraubenzieher die Zylinderschraube lösen. Das Schneidrad ersetzen. Schraube anziehen und Arretierstift entfernen.



Gefahr

Zurückschnellendes Schneidrad

Gliedmassen können verletzt werden! Das Schneidrad darf nur bei arretiertem Hebel gewechselt werden.



Hinweis

Schneidrad-Achse

Seit Januar 2002 werden nur noch abgesetzte Achsen verwendet. Diese Achsen ersetzen den Zylinderstift mit Buchse. Bei einem allfälligen Wechsel des Schneidrades muss, insofern noch nicht vorhanden, eine abgesetzte Achse eingesetzt werden. Diese ist unter der Art. Nr. 16 003 15 erhältlich.

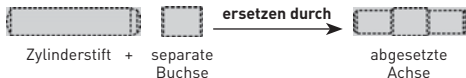

Biegen mit Handbiegeschablone



Rohrbogen anzeichnen.
Rohr in die Handbiegeschablone einführen.
Biegeanfang beachten.



Biegen des Rohrbogens.
Das Rohr muss beim Biegen
möglichst nahe der Biegelehre
entlang geführt werden.



Fertiger Rohrbogen aus der
Handbiegeschablone nehmen.

Bogenmass (cm)

d	90°	60°	45°	30°
16	5.6	3.2	2.3	1.5
20	7.0	4.0	2.9	1.9
26	9.1	5.3	3.8	2.4



Hinweis
Überprüfung der Werkzeuge

Ein gut funktionierendes, sauberes Werkzeug ist eine Grundvoraussetzung für eine dauerhaft dichte Verbindung.

Wir empfehlen deshalb, die Werkzeuge zu pflegen und diese regelmässig, einmal jährlich auf Ihre Funktionstüchtigkeit überprüfen zu lassen.

Unser Technischer Verkaufsberater steht Ihnen dazu gerne zur Verfügung.



Achtung
Reparaturen an Werkzeugen

An JRG Sanipex MT-Werkzeugen dürfen keine Reparaturen oder Veränderungen der Werkzeugeinstellungen vorgenommen werden. Bei Zuwiderhandlungen entfällt jegliche Gewährleistung und Haftung.

Bei defekten Werkzeugen kontaktieren Sie unseren Technischen Verkaufsberater.

Instructions d'emploi et de montage

JRG Sanipex MT
4800.000/.050
d16/20/26

Coffret de montage

F 13 – 27



+GF+

JRG

Instructions d'emploi et de montage

Veillez lire attentivement les présentes instructions d'emploi et de montage avant d'utiliser les outils.

La procédure de montage s'applique par analogie aux tubes VPE JRG Sanipex.

Voici ce que signifient les symboles utilisés:



Avertissement

Ce symbole renvoie à une information dont le non-respect pourrait provoquer d'importants dommages matériels. Les indications de sécurité doivent être observées.



Note

Ce symbole renvoie à une information contenant des indications importantes sur l'emploi. Leur non-observation pourrait provoquer des dérangements.

Les instructions d'emploi et de montage font partie de l'outillage de montage **JRG Sanipex MT**. Elles doivent être conservées dans le coffret de montage.

**Description de
la pince à élargir
JRG Sanipex MT**

- 1 Tige de guidage
- 2 Mâchoires
- 3 Levier de travail
- 4 Levier de fixation
- 5 Mandrin d'élargissement

Coffret de montage d16+20+26, no JRG 4800.000/.050

Le coffret de montage 4828.000 contient:

- 4804.000** Pince à élargir
- 4832.016** Clé dynamométrique à cliquet 16
- 4832.020** Clé dynamométrique à cliquet 20
- 4832.026** Clé dynamométrique à cliquet 26
- 4834.016** Contre-clé 16
- 4834.020** Contre-clé 20
- 4834.026** Contre-clé 26
- 4806.016** Chablon de cintrage à main 16
- 4806.020** Chablon de cintrage à main 20
- 4806.026** Chablon de cintrage à main 26 (optionnelle)
- 4837.000** Pince combinée 16/20
- 4836.000** Coupe-tube
- 4838.000** Marqueur
- 5777.000** Douille d'ajustage 1/2"
- 5790.008** Clé de montage de boîtes
- 4804.016** Mâchoires 16
- 4804.020** Mâchoires 20
- 4804.026** Mâchoires 26
- 4804.116** Mandrin d'élargissement 16 pour tube MT
- 4804.120** Mandrin d'élargissement 20 pour tube MT
- 4804.126** Mandrin d'élargissement 26 pour tube MT
- 4804.216** Mandrin d'élargissement 16 pour tube PE-X
- 4804.220** Mandrin d'élargissement 20 pour tube PE-X
- 09 458 55** Instructions d'emploi et de montage

Introduction

L'outillage de montage JRG Sanipex MT est exclusivement destiné au montage des systèmes sanitaires JRG Sanipex MT, si ils sont utilisés conformément, il ne requièrent aucun entretien particulier.

Les outils ne doivent être appliqués qu'à des composants du système JRG Sanipex MT.

Ces outils ne doivent pas être utilisés à d'autres fins.

Aucune réparation ni modification de quelque nature que ce soit ne peuvent être effectuées ou apportées aux outils composant l'outillage JRG Sanipex MT.

Les tubes suivant peuvent être sertis avec la pince à élargir JRG Sanipex MT (no JRG 4800.000):

4600.016 – .026	Tube JRG Sanipex MT	d16–d26	noir, en barres, 5 m
4600.316 – .326	Tube JRG Sanipex MT	d16–d26	noir, en barres, 3 m
4602.016 – .020	Tube JRG Sanipex MT	d16–d20	blanc, en rouleau, avec tube protecteur
4604.016 – .026	Tube JRG Sanipex MT	d16–d26	blanc, en rouleau
4606.016 – .026	Tube JRG Sanipex MT	d16–d26	blanc, en rouleau, isolé
5706.016/.020	Tube JRG Sanipex	d16/d20	blanc, en rouleau, avec tube protecteur
5707.016/.020	Tube JRG Sanipex	d16/d20	blanc, en rouleau
5716.016/.020	Tube JRG Sanipex	d16/d20	bleu, en rouleau, avec tube protecteur
5717.016/.020	Tube JRG Sanipex	d16/d20	bleu, en rouleau

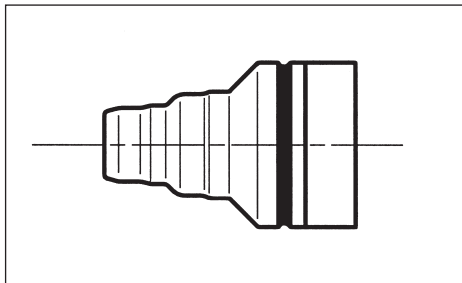

Choisir les mandrins d'élargissement

Pour les tubes JRG Sanipex MT d16 x 2,25
mandrin avec une rainure, noir

Pour les tubes JRG Sanipex MT d20 x 2,5
mandrin avec une rainure, bleu

Pour les tubes JRG Sanipex MT d26 x 3,0
mandrin avec une rainure, rouge

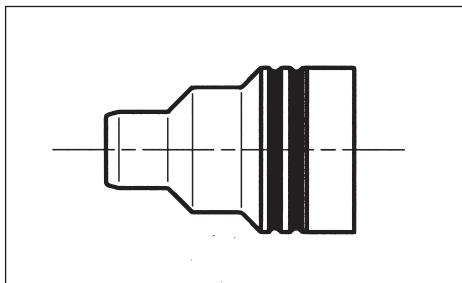

Pour les tubes JRG Sanipex PE-Xa et PE-Xc d16 x 2,2
mandrin avec deux rainures, noir

Pour les tubes JRG Sanipex PE-Xa et PE-Xc d20 x 2,8
mandrin avec deux rainures, bleu

Changement du mandrin d'élargissement



Fermer un peu le levier de travail (3) et le maintenir dans cette position. Ceci décharge le mécanisme de maintien. En pressant la tige de guidage (1), le mandrin d'élargissement (5) est libéré. Maintenir le levier de travail dans la même position.

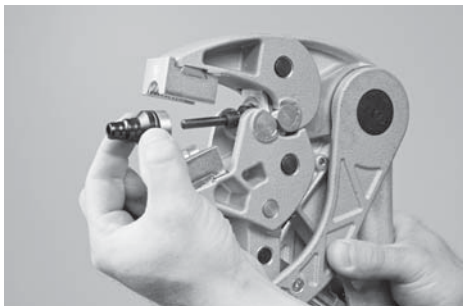

Glisser le mandrin d'élargissement (5) désiré sur la tige de guidage (1), presser sur celle-ci et faire glisser le mandrin d'élargissement (5) jusqu'en butée. Le changement du mandrin d'élargissement (5) est terminé lorsque l'on relâche la tige de guidage (1).

Changement des mâchoires



Sortir les mâchoires (2) des glissières en les tirants de côté, les remplacer par les mâchoires désirées.

Montage



Couper à la longueur désirée le tube JRG Sanipex MT d16 ou d20 à l'aide de la pince combinée (no JRG: 4837) et d26 avec coupe-tube (no JRG: 4836).



Après avoir glissé l'écrou de raccordement, introduire le tube JRG Sanipex MT jusqu'au seuil de résistance sur le mandrin dans la pince d'élargissement et fermer le levier de fixation (4).



Note

Mandrin d'élargissement correct

Veuillez à utiliser un mandrin d'élargissement (5) et des mâchoires (2) adaptés au tube.



Mener le processus d'élargissement en refermant le levier de travail (3).

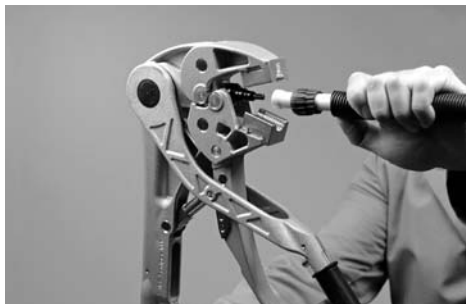

Ouvrir le levier de travail (3). L'extrémité du tube, maintenant dotée d'un rebord, est libérée.



Note
Élargissement de tubes
JRG Sanipex en PE-X

Le raccord doit être effectué immédiatement lorsque l'on a élargi des tubes JRG Sanipex PE-X flexibles.

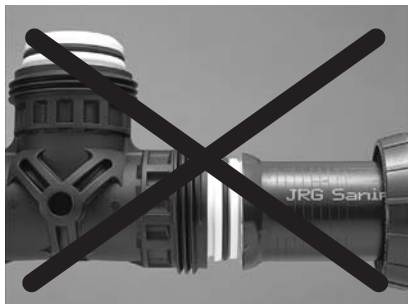
Assemblage correct**Assemblage faux**

Contrôle du processus d'élargissement.
Le joint O-ring du raccord doit être entièrement recouvert par le rebord du tube.

**Avertissement**
Rebord mal formé

Les rebords de tube mal formés
ne doivent pas être retravaillés!



Enfiler le tube JRG Sanipex MT doté de son rebord sur le raccord JRG Sanipex MT. Serrer à la main l'écrou de raccord.



Serrer ensuite l'écrou de raccord à l'aide de la clé dynamométrique à cliquet (no JRG: 4832). Pour maintenir, utiliser une douille d'ajustage (no JRG: 5777) ou la contre-clé (no JRG: 4834).

**Avertissement****Dérangements dans le fonctionnement de la clé dynamométrique à cliquet**

En cas de dérangement ou si la clé est endommagée, nous recommandons de procéder au remplacement de la clé dynamométrique à cliquet JRG Sanipex MT.

**Avertissement****Réparations de la clé dynamométrique à cliquet**

Aucune réparation ne doit être pratiquée sur la clé dynamométrique à cliquet JRG Sanipex MT.

**Note****Clé dynamométrique à cliquet**

Les clés dynamométrique à cliquet JRG Sanipex MT servent exclusivement au serrage des raccords à rebords JRG Sanipex MT. Les couples correspondants sont réglés d'usine. Aucun entretien n'est nécessaire en cas d'utilisation conforme.

Remplacement de la molette



Ouvrir complètement le coupe-tubes en actionnant le levier. Faire glisser la cheville d'arrêt (p.ex. aiguille de Ø 3 mm) au travers du perçement. De ce fait, le coupe-tubes restera en position ouverte en toute sécurité.



Danger **Brusque détente de la molette**

Les membres peuvent être blessés!
Il convient de remplacer la molette uniquement lorsque le levier est arrêté.



Desserrer la vis à tête cylindrique à l'aide d'un tourne-vis.
Remplacer la molette. Serrer la vis et retirer la cheville d'arrêt.



Note **Axe de la molette**

Depuis janvier 2002, seuls des axes étagés sont utilisés. Ces axes remplacent la cheville cylindrique avec douille. Lors d'un éventuel remplacement de la molette, il convient, pour autant qu'il n'existe pas encore, de poser un axe étagé, livrable sous le no. Art.16 003 15.



Pliage à l'aide du gablon de cintrage à main



Tracer l'arc du tube.
Introduire le tube dans le
gablon de cintrage à main.
Observer le début du pliage.



Pliage du tube en arc.
Pendant le pliage, le tube doit
être maintenu le mieux possi-
ble le long du gabarit de pliage.



Retirer les arcs de tube
terminés hors du gablon de
cintrage à main.

Angle (cm)

d	90°	60°	45°	30°
16	5.6	3.2	2.3	1.5
20	7.0	4.0	2.9	1.9
26	9.1	5.3	3.8	2.4



Note
Contrôle des outils

Un outil propre et en parfait état de fonctionnement est la condition fondamentale pour l'obtention d'un assemblage durablement étanche.

C'est la raison pour laquelle, nous recommandons de soigner les outils et de régulièrement faire contrôler leur état de fonctionnement une fois par année.



Attention
Réparation des outils

Il est formellement interdit de procéder à des réparations et des modifications aux réglages d'usine des outils JRG Sanipex MT. En cas de dérogation, nous déclinons toute garantie et responsabilité.

Pour les outils défectueux, veuillez contacter notre conseiller de vente technique.

Istruzioni d'uso e montaggio

JRG Sanipex MT
4800.000/.050
d16/20/26

Valigetta di montaggio | 29 – 43



+GF+

JRG

Istruzioni d'uso e di montaggio

Vi preghiamo di leggere attentamente le presenti istruzioni d'uso e di montaggio prima di usare l'attrezzo.

La procedura di montaggio è anche valida per i tubi JRG Sanipex PE-X.

I simboli rappresentati significano:



Avvertimento

Questo segnale richiama l'attenzione su un'informazione che se trascurata, può essere causa di notevoli danni a cose. È necessario attenersi rigorosamente alle norme di sicurezza.



Istruzione

Questo segnale richiama l'attenzione su un'informazione contenente importanti indicazioni concernenti l'uso. L'inosservanza di queste indicazioni può causare guasti.

Le istruzioni d'uso e di montaggio costituiscono una parte integrante della valigia di montaggio **JRG Sanipex MT**. Esse vanno pertanto conservate nella valigia.

Costruzione dell'espansore manuale JRG Sanipex MT

- 1 Spina di guida
- 2 Morsetti di chiusura
- 3 Leva di lavoro
- 4 Leva di chiusura
- 5 Mandrino allargatubi

Valigetta di montaggio d16+20+26, JRG no. 4800.000/.050

La valigia 4828.000 contiene:

4804.000	Espansore manuale
4832.016	Chiave dinamometrica a raganella 16
4832.020	Chiave dinamometrica a raganella 20
4832.026	Chiave dinamometrica a raganella 26
4834.016	Controchiave 16
4834.020	Controchiave 20
4834.026	Controchiave 26
4806.016	Curvatubi manuale 16
4806.020	Curvatubi manuale 20
4806.026	Curvatubi manuale 26 (opzionale)
4837.000	Forbice universale 16/20
4836.000	Tagliatubo
4838.000	Raschietto di marcatura
5777.000	Guida a tubo 1/2"
5790.008	Chiave di montaggio per scatole
4804.016	Morsetti di chiusura 16
4804.020	Morsetti di chiusura 20
4804.026	Morsetti di chiusura 26
4804.116	Mandrino allargatubi 16 per tubo MT
4804.120	Mandrino allargatubi 20 per tubo MT
4804.126	Mandrino allargatubi 26 per tubo MT
4804.216	Mandrino allargatubi 16
4804.220	Mandrino allargatubi 20
09 458 55	Istruzioni d'uso e di montaggio

Introduzione

Gli attrezzi di montaggio JRG Sanipex MT sono destinati esclusivamente al montaggio dei sistemi d'installazione JRG Sanipex MT e, se usati appropriatamente, non richiedono ulteriore manutenzione.

Gli attrezzi contenuti possono essere utilizzati soltanto per i componenti del sistema JRG

Sanipex MT e non possono essere utilizzati per fini diversi.

Sugli attrezzi JRG Sanipex MT non possono essere eseguite riparazioni né modifiche di qualsiasi natura.

I seguenti tubi possono essere allargati con l'espansore manuale (JRG no. 4800.000) JRG Sanipex MT:

4600.016 - .026	Tubo JRG Sanipex MT	d16-d26	nero, in barre, 5 m
4600.316 - .326	Tubo JRG Sanipex MT	d16-d26	nero, in barre, 3 m
4602.016 - .020	Tubo JRG Sanipex MT	d16-d20	bianco, in bobine, con guaina
4604.016 - .026	Tubo JRG Sanipex MT	d16-d26	bianco, in bobine
4606.016 - .026	Tubo JRG Sanipex MT	d16-d26	bianco, in bobine, isolato
5706.016/.020	Tubo JRG Sanipex	d16/d20	bianco, in bobine, con guaina
5707.016/.020	Tubo JRG Sanipex	d16/d20	bianco, in bobine
5716.016/.020	Tubo JRG Sanipex	d16/d20	blu, in bobine, con guaina
5717.016/.020	Tubo JRG Sanipex	d16/d20	blu, in bobine

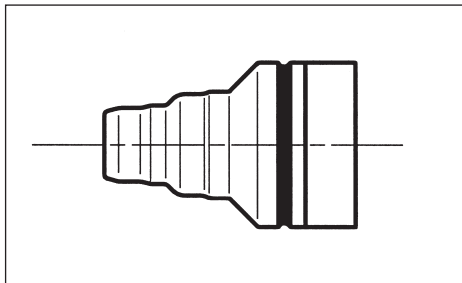

Scelta dei mandrini espansori

Per tubi JRG Sanipex MT d16 x 2,25
Mandrino espansore, con una scanalatura, nero

Per tubi JRG Sanipex MT d20 x 2,5
Mandrino espansore, con una scanalatura, blu

Per tubi JRG Sanipex MT d26 x 3,0
Mandrino espansore, con una scanalatura, rosso

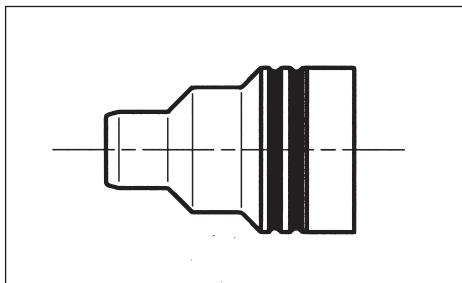

Per tubi JRG Sanipex PE-Xa e PE-Xc d16 x 2,2
Mandrino espansore, con due scanalature, nero

Per tubi JRG Sanipex PE-Xa e PE-Xc d20 x 2,8
Mandrino espansore, con due scanalature, blu

Cambio del mandrino allargatubi



Chiudere un poco la leva di lavoro (3) e tenerla in questa posizione. A questo modo si rilascia il meccanismo di presa. Spingendo la spina di guida (1) il mandrino allargatubi (5) viene liberato. Tenere la leva di lavoro invariata.

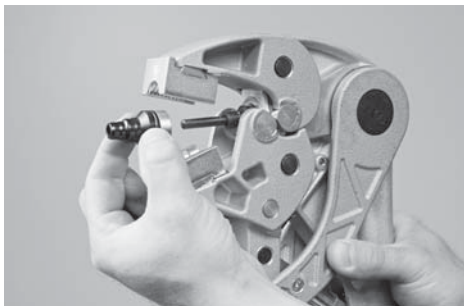

Infilare il mandrino allargatubi (5) desiderato sulla spina di guida (1). Spingere la spina di guida (1) e mandare in battuta il mandrino allargatubi (5).

Il cambio del mandrino allargatubi (5) ha avuto luogo quando si rilascia la spina di guida (1).

Cambio dei morsetti di chiusura



Sfilare lateralmente i morsetti di chiusura (2) dalla guida e infilare i morsetti di chiusura desiderate.

Procedimento di montaggio



Tagliare il tubo JRG Sanipex MT d16 o d20 alla lunghezza desiderata usando la forbice universale (JRG no. 4837) e d26 con tagliatubo (JRG no. 4836).



Attenzione: ricordarsi di inserire il dado del raccordo sul tubo. Appoggiare il mandrino espansore della pinza al tubo fino al fermo, serrare la leva di chiusura (4). Azionare fino in fondo la leva di lavoro.



Istruzione

Giusto mandrino allargatubi

Assicurarsi che il mandrino allargatubi (5) ed i morsetti di chiusura (2) abbiano le dimensioni giuste per il tubo impiegato.



Procedere per l'allargamento del tubo chiudendo la leva di lavoro (3).

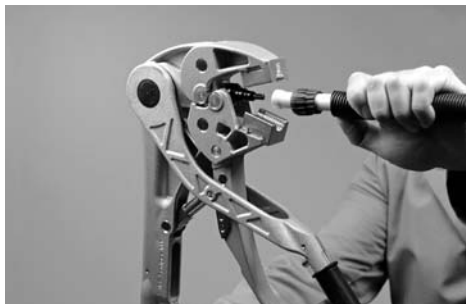

Aprendo la leva di lavoro (3) si libera l'estremità allargata del tubo.



Istruzione
Allargamento di tubi
JRG Sanipex in PE-X

In caso di lavori d'allargamento di tubi flessibili JRG Sanipex PE-X occorre immediatamente completare tutto il raccordo.

Raccordo a morsetto corretto



Raccordo a morsetto errato

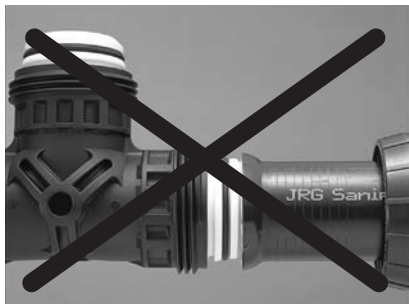

Controllo del procedimento d'allargamento
L'O-ring del raccordo deve essere comple-
tamente coperto dalla bordatura.



Avvertimento **Bordatura di tubo non corretta**

Le bordature effettuate non
correttamente, non possono
essere rifatte!



Innestare il tubo JRG Sanipex MT allargato nel raccordo JRG Sanipex MT. Stringere forte a mano il dado di chiusura.



Stringere il dado di chiusura con la chiave dinamometrica a raganella cricco (JRG no. 4832). Usare la guida del tubo (JRG no. 5777) o la controchiave (JRG no. 4834) per contrastare lo sforzo di torsione generato dalla chiusura.

**Avvertimento****Disturbi di funzionamento della chiave dinamometrica a raganella**

In caso di difetti di funzionamento o in caso di danni subiti, consigliamo di sostituire le chiavi dinamometriche a raganella JRG Sanipex mediante cambio.

**Avvertimento****Riparazioni delle chiavi dinamometriche a raganella**

Non è consentito effettuare riparazioni alle chiavi dinamometriche a raganella JRG Sanipex MT.

**Istruzione****Chiave dinamometrica a raganella**

Le chiavi dinamometriche a raganella JRG Sanipex MT servono unicamente al serraggio di raccordi a morsetto da bordare JRG Sanipex MT. I rispettivi valori di coppia sono stati regolati in fabbrica e, se usati per lo scopo predestinato, non richiedono ulteriori aggiustamenti.

Sostituzione della rotella di taglio



Aprire completamente il tagliatubi azionando la leva. Spingere nel foro la spina di fermo (ad es. chiodo da $\varnothing 3$ mm). Così, il tagliatubi rimane aperto in modo sicuro.



Allentare la vite a testa cilindrica con un cacciavite. Sostituire la rotella di taglio. Serrare la vite e togliere la spina di fermo.



Pericolo
Rotella di taglio con ritorno a molla
 Possibilità di lesione degli arti!
 La rotella di taglio può essere sostituita solo con la leva bloccata.



Istruzione Rotella di taglio – alberino

Dal gennaio 2002, vengono impiegati solo alberini sfalsati. Questi alberini sostituiscono la spina cilindrica con la boccola. In caso di eventuale sostituzione della rotella di taglio, deve essere impiegato un alberino sfalsato se non ancora esistente. Questo è disponibile con il numero di articolo 16 003 15.



Piegatura con curvatubi manuale



Marcare la curva. Infilare il tubo nella dima. Prestare attenzione all'inizio della curva.



Piegatura del tubo. Durante la piegatura il tubo deve possibilmente seguire da vicino la curvatura della dima.



Estrarre la curva finita dalla dima.

Misura della curva [cm]

d	90°	60°	45°	30°
16	5.6	3.2	2.3	1.5
20	7.0	4.0	2.9	1.9
26	9.1	5.3	3.8	2.4



Istruzione
Controllo degli attrezzi

Un attrezzo pulito e ben funzionante è la premessa per un accoppiamento ermetico durevole.

Pertanto, vi raccomandiamo di curare gli attrezzi e di farli controllare regolarmente una volta all'anno per la loro funzionalità.

Il nostro consulente tecnico di vendita è a vostra disposizione.



Avvertimento
Riparazioni degli attrezzi

Non si devono effettuare riparazioni o modifiche delle regolazioni di fabbrica sugli attrezzi JRG Sanipex MT. In caso di violazione, decade qualsiasi garanzia e responsabilità.

Contattate il nostro consulente tecnico di vendita in caso di attrezzi difettosi.

Operating- and installation
instructions

JRG Sanipex MT
4800.000/.050
d16/20/26

Fitter's toolkit

E 45 – 59



+GF+

JRG

Operating- and installation instructions

Please read carefully the operating- and installation instructions presented here before using any of the tools.

The installation procedure is also applicable in analogy for JRG Sanipex PE-X pipes.

The symbols utilized signify:



Warning

This symbol draws attention to information, the non-observance of which may lead to extensive material damage. The safety indications have to be observed.



Remark

This symbol draws attention to information, which contains important indications with respect to the utilization. Non-observance may lead to malfunctions.

The operating- and installation instructions are a component part of the **JRG Sanipex MT** installation tools. They have to be stored in the tool box available for consultation.

Construction of the JRG Sanipex MT expansion pliers

- 1 Guide pin
- 2 Clamping jaws
- 3 Operating lever
- 4 Clamping lever
- 5 Expansion mandrel

Filter's toolkit d16+20+26, JRG no. 4800.000/.050

Contained in the filter's toolkit 4828.000 are the following:

4804.000	Expansion pliers
4832.016	Ratchet torque wrench 16
4832.020	Ratchet torque wrench 20
4832.026	Ratchet torque wrench 26
4834.016	Countering spanner 16
4834.020	Countering spanner 20
4834.026	Countering spanner 26
4806.016	Hand bending template 16
4806.020	Hand bending template 20
4806.026	Hand bending template 26 (optional)
4837.000	Multi-purpose cutter 16/20
4836.000	Pipe cutter
4838.000	Marking pen
5777.000	Alignment gauge 1/2"
5790.008	Box assembly key
4804.016	Clamping jaws 16
4804.020	Clamping jaws 20
4804.026	Clamping jaws 26
4804.116	Expansion mandrel 16 for pipe MT
4804.120	Expansion mandrel 20 for pipe MT
4804.126	Expansion mandrel 26 for pipe MT
4804.216	Expansion mandrel 16 for pipe PE-X
4804.220	Expansion mandrel 20 for pipe PE-X
09 458 55	Operating- and installation instructions

Introduction

The JRG Sanipex MT installation tools are exclusively foreseen for utilization with the JRG Sanipex MT installation system, and providing they are used correctly and in accordance with their purpose they do not require any further maintenance or servicing.

Only JRG Sanipex MT systems components must be processed with these tools. The tools must not be utilized for other purposes.

No repairs or modifications of any kind whatsoever must be carried out on JRG Sanipex MT tools.

The following pipes can be expand with the JRG Sanipex MT expanding pliers (JRG no. 4800.000):

4600.016 – .026	JRG Sanipex MT pipe	d16–d26	black, in bars, 5 m
4600.316 – .326	JRG Sanipex MT pipe	d16–d26	black, in bars, 3 m
4602.016 – .020	JRG Sanipex MT pipe	d16–d20	white, in coils with protective conduit
4604.016 – .026	JRG Sanipex MT pipe	d16–d26	white, in coils
4606.016 – .026	JRG Sanipex MT pipe	d16–d26	white, in coils, isolated
5706.016/.020	JRG Sanipex pipe	d16/d20	white, in coils with protective conduit
5707.016/.020	JRG Sanipex pipe	d16/d20	white, in coils
5716.016/.020	JRG Sanipex pipe	d16/d20	blue, in coils with protective conduit
5717.016/.020	JRG Sanipex pipe	d16/d20	blue, in coils

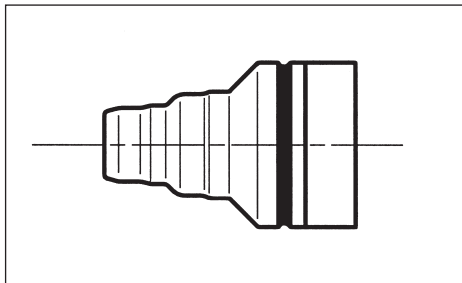

Selection of the expansion mandrels

For JRG Sanipex MT pipes d16 x 2.25
Expansion mandrel with one groove, black

For JRG Sanipex MT pipes d20 x 2.5
Expansion mandrel with one groove, blue

For JRG Sanipex MT pipes d26 x 3.0
Expansion mandrel with one groove, red

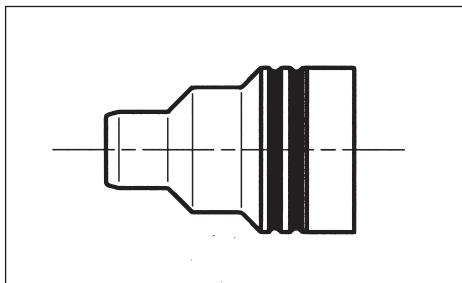

For JRG Sanipex PE-Xa and PE-Xc pipes d16 x 2.2
Expansion mandrel with two grooves, black

For JRG Sanipex PE-Xa and PE-Xc pipes d20 x 2.8
Expansion mandrel with two grooves, blue

Changing the expansion mandrels



Close the operating lever (3) slightly and hold it in this position. As a result of this, the holding mechanism is relieved. The expansion mandrel (5) is released by pressing the guide pin (1). Keep holding the operating lever the same way.

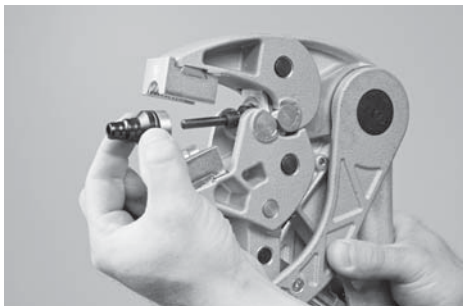

Slide the required expansion mandrel (5) over the guide pin (1). Press the guide pin (1) and slide the expansion mandrel (5) right up to the stop. The changing of the expansion mandrel (5) has been completed, as soon as the guide pin (1) is released.

Changing the clamping jaws



Push the clamping jaws (2) laterally from the clamping jaw guide and insert the desired clamping jaws.

Installation procedure



Cut the JRG Sanipex MT pipe d16 or d20 to the required length with the multi-purpose-cutter (JRG no. 4837) and d26 to pipe cutter (JRG no. 4836).



After sliding over the plastic nut, the JRG Sanipex MT pipe has to be pushed over the mandrel until the mark, after that close the clamping lever (4).



Remark

Correct expansion mandrel

Pay attention, that the expansion mandrel (5) corresponding to the respective pipe as well as the clamping jaws (2) corresponding to the respective dimension are in place.



Carry out the expansion process by closing the operating lever (3).



Open the operating lever (3) and the flared pipe end is released.



Remark
Expansion of JRG Sanipex
pipes made of PE-X

After the flaring of flexible JRG Sanipex pipes PE-X, the connection has to be completed immediately.

Clamping joint, correct



Clamping joint, incorrect

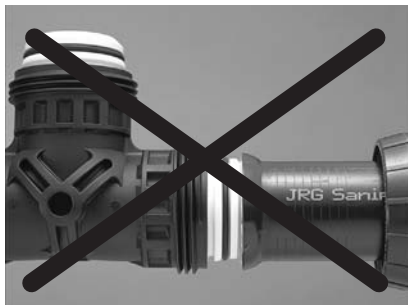

Checking the flaring process.
The O-ring at the fitting has to be completely covered by the pipe flare.



Warning
Not correctly formed pipe flare
Must not be expanded once again!

E



Insert the flared JRG Sanipex MT pipe onto the JRG Sanipex MT fitting. Tighten the union nut by hand only.



Finally tighten the union nut with the ratchet torque wrench (JRG no. 4832). For counter-bracing, use the alignment gauge (JRG no. 5777) or the counterbracing spanner (JRG no. 4834).

**Warning****Operational malfunctions of the ratchet torque wrench**

In the case of any operational malfunctions or in case of any damage, we recommend, that the JRG Sanipex MT ratchet torque wrench should be replaced by exchanging it with a new or works refurbished one.

**Warning****Repairs to the ratchet torque wrenches**

Absolutely no repairs must be carried out on JRG Sanipex MT ratchet torque wrenches.

**Remark****Ratchet torque wrenches**

The JRG Sanipex MT ratchet torque wrenches are destined exclusively for the tightening of JRG Sanipex MT flared clamped joints. The corresponding torques are adjusted fixed by the manufacturing works and in case of correct and proper usage the torque wrenches do not require any further servicing or maintenance.

Replacement of pipe cutter wheel



Open the pipe cutter by operating the lever.
Push lock bolt (e.g. nail of $\varnothing 3$ mm) through the drilled hole.
Thus the pipe cutter remains secured open.



Detach the screw with a screwdriver.
Replace the pipe cutter wheel.
Tighten the screw and remove the lock bolt.



Danger **Resile of pipe cutter wheel**

Fingers can be hurt!
The pipe cutter wheel have to be changed only with locked lever.



Notice **Cutting wheel – axis**

Since January 2002 only hubbed axis are used. These axis replaces the cylindrical bolt with socket. A hubbed axis have to be used, as far as not yet available, changing the cutter wheel. The hubbed axis has the art. no. 16 003 15.



Bending with the manual bending template



Mark the pipe bend. Insert the pipe into the manual bending template. Pay attention to the start of the bend.



Bending the pipe bend. During bending, the pipe has to be guided as closely along the bending gauge as possible.



Remove the completed pipe bend from the manual bending template.

Bending angle (cm)

d	90°	60°	45°	30°
16	5.6	3.2	2.3	1.5
20	7.0	4.0	2.9	1.9
26	9.1	5.3	3.8	2.4



Note
Tools inspection

A tool that is well working and clean is the basic condition for a durably tight connection.

We recommend therefore to maintain the tools regularly and let them check once a year on efficiency.

Our technical advisers are at your disposal for this.



Warning
Repairs on tools

On JRG Sanipex MT-tools no repairs or changes of factory settings may be made. Through contravention any guarantee and adhesion are void.

Contact our technical advisers if there are defective tools.

Georg Fischer JRG AG

Hauptstrasse 130

CH-4450 Sissach

Phone +41 (0)61 975 22 22, Fax +41 (0)61 975 22 00

www.jrg.ch, info.jrg.ps@georgfischer.com

Georg Fischer JRG SA

Via Boscioro 20

CH-6962 Viganello/Lugano

Phone +41 (0)91 972 26 26, Fax +41 (0)91 972 26 27

www.jrg.ch, ti.jrg.ps@georgfischer.com

Georg Fischer GmbH

Nördliche Grünauerstrasse 65

D-86633 Neuburg/Donau

Phone +49 (0)8431 5817-0, Fax +49 (0)8431 5817-20

www.jrg.de, info.jrg.ps@georgfischer.com