

~~zu den ...~~

Service



3321/00042-

Hydraulic motors OMP, OMPC, OMPW and OMPW N series 7 and 8 Metric versions

Spare parts list / service manual

HN.11.K9.52 replaces HN.11.K8.52

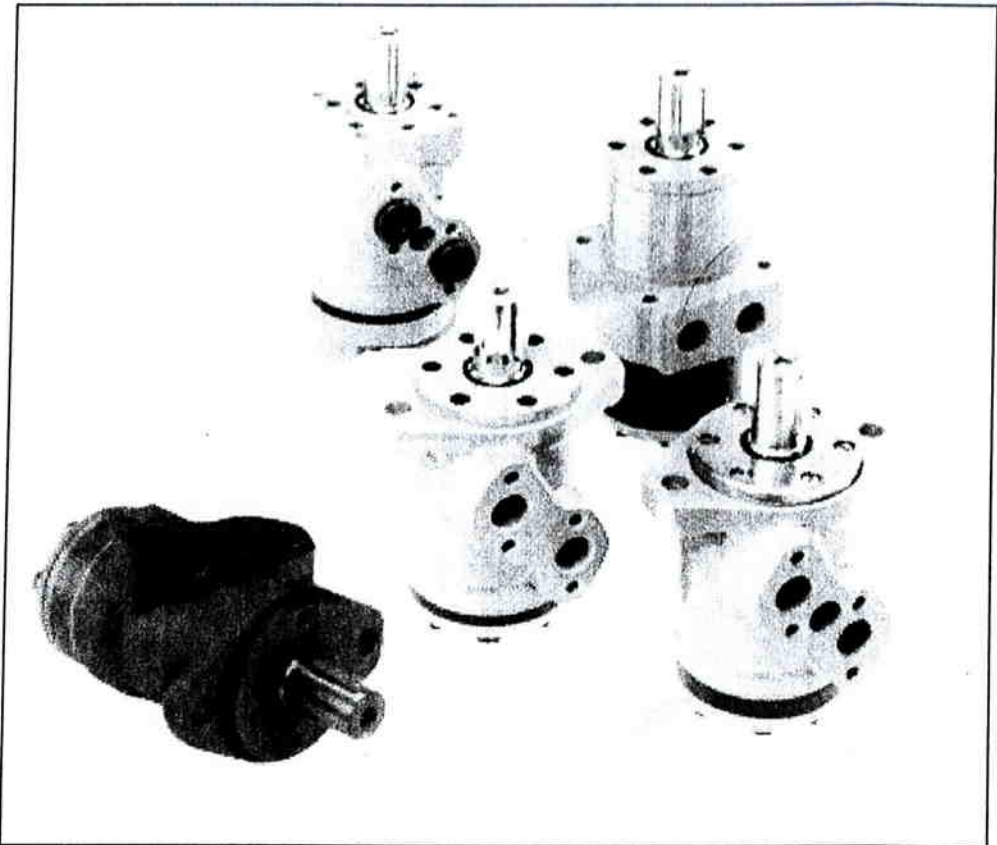

Index

Page

Cost-free repairs	2
Authorized Service shops	2
Exploded view: OMP series 8 with integrated spigot flange ...	3
Exploded view: OMP and OMP C series 7 and 8 with separate spigot flange	4
Exploded view: OMPW and OMPW N series 7 and 8.....	5
Spare parts list	6
Tightening torque	9
Dismantling	10
Assembly.....	14

Type Serie 2

Vederlagsfri reparation	Vi gør opmærksom på at den vederlagsfrie reparation som er omtalt i Danfoss Almindelige Leveringsbetingelser kun udføres hos Danfoss Nordborg eller hos Danfoss autoriserede service shops (side 2).
Cost-free repairs	We would point out that cost-free repairs as mentioned in Danfoss General Conditions of Sale, are carried out only at Danfoss Nordborg or at service shops authorized by Danfoss (page 2).
Kostenlose Reparatur	Wir machen darauf aufmerksam, dass die in den "Allgemeinen Lieferbedingungen" von Danfoss erwähnte kostenlose Reparatur nur bei Danfoss Nordborg oder bei den von Danfoss autorisierten Kundendienstwerkstätten ausgeführt wird (Seite 2).
Réparation gratuite	Nous faisons observer que la réparation gratuite mentionnée dans les Conditions générales de Vente de Danfoss ne devra être effectuée que dans les ateliers Danfoss à Nordborg ou dans les ateliers de dépannage agréés par Danfoss (page 2).

Authorized Service Shops	Australia	: Danfoss (Australia) Pty. Ltd., Melbourne
	Austria	: Hainzl Industriesysteme, GmbH., Linz
	Belgium	: N.V. Danfoss S.A., Bruxelles
	Brazil	: Danfoss do Brasil Ind. e Com. Ltda., São Paulo
	Canada	: Danfoss Mfg. Ltd., Mississauga
	Denmark	: Danfoss Hydraulik A/S, Ganløse
	Finland	: OY Danfoss AB, Espoo
	France	: Danfoss S.a.r.l., Trappes (Paris)
	Germany	: Danfoss GmbH., Offenbach/Main
	Great Britain	: Danfoss Limited, Greenford (London)
	Iceland	: Hedinn Verslun HF, Reykjavik
	India	: Dantal Hydraulics PVT Ltd., New Delhi
	Italy	: Danfoss s.r.l. Division Sordella, Torino
	Japan	: Danfoss K.K., Gotemba
	Korea	: Unitek Corporation, Seoul
	Netherlands	: Itho B.V., Schiedam
	New Zealand	: Danfoss (New Zealand) Limited, Auckland
	Norway	: Danfoss A/S, Skui
	Republic of South Africa	: Danfoss (Pty) Ltd., Johannesburg
	Singapore	: Danfoss Industries Pte. Ltd., Singapore
	Spain	: Danfoss S.A., San Sebastian de los Reyes, (Madrid)
	Sweden	: Danfoss AB, Mjölby
	Switzerland	: Danfoss Werner Kuster AG, Frenkendorf
	Turkey	: Mert Teknik A.S., Istanbul
	U.S.A.	: Danfoss Fluid Power Div. Racine, Wisconsin

Service Shops	Australia	: Danfoss (Australia) Pty. Ltd., Adelaide
	Australia	: Danfoss (Australia) Pty. Ltd., Brisbane
	Australia	: Danfoss (Australia) Pty. Ltd., Perth
	Australia	: Danfoss (Australia) Pty. Ltd., Sydney
	Czech Rep.	: Techno Trade, Olomouc
	Greece	: A. Skoura & Co. E.E., Athens
	New Zealand	: Danfoss (New Zealand) Limited, Christchurch
	Taiwan	: Symbridge Machinery Co. Ltd., Taipei

**Exploded view
OMP and OMP C
Metric version, series 7 and 8 with separate splgot flange**

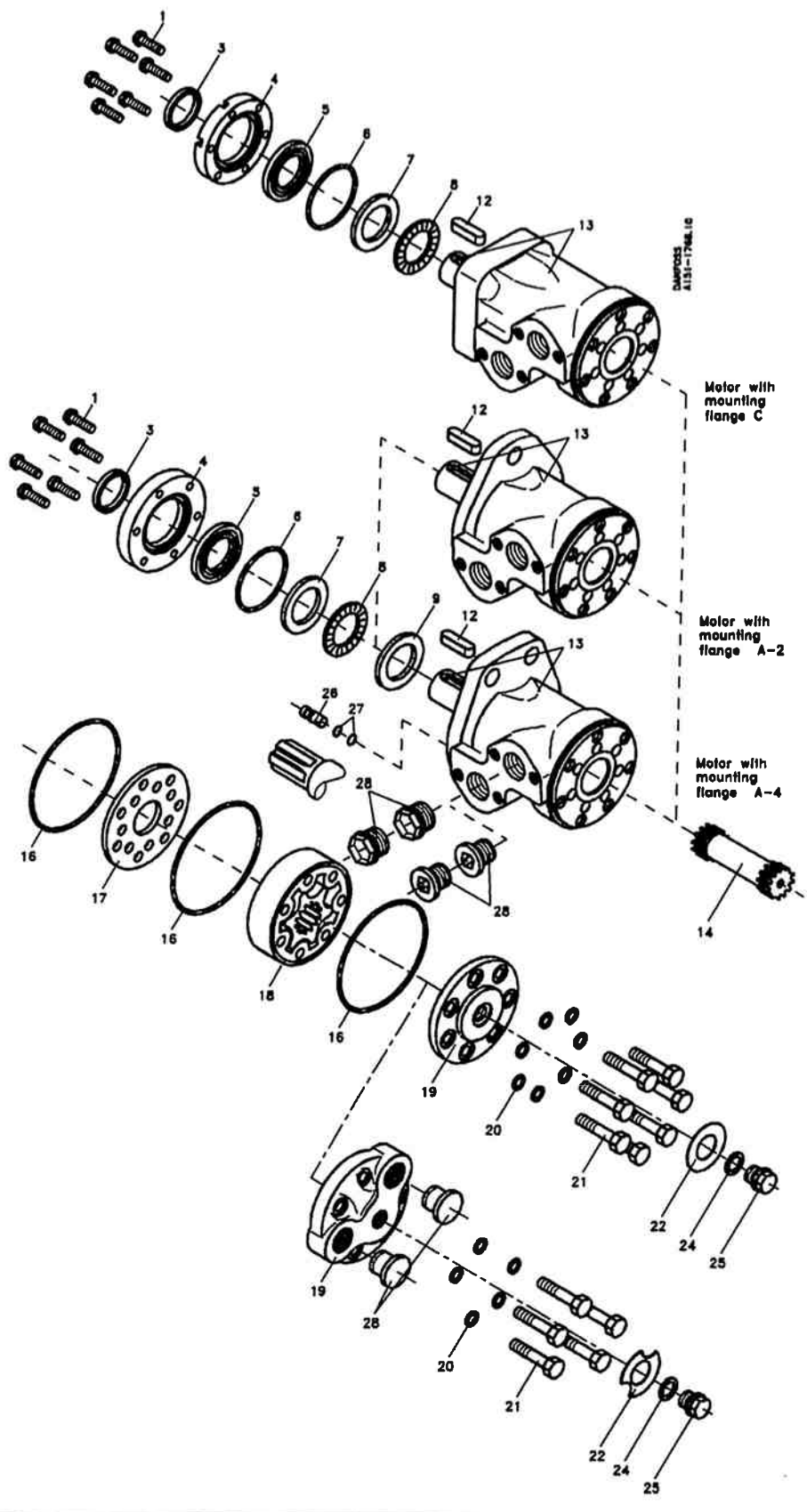

**Exploded view OMPW and OMPW N
Metric version, series 7 and 8.**

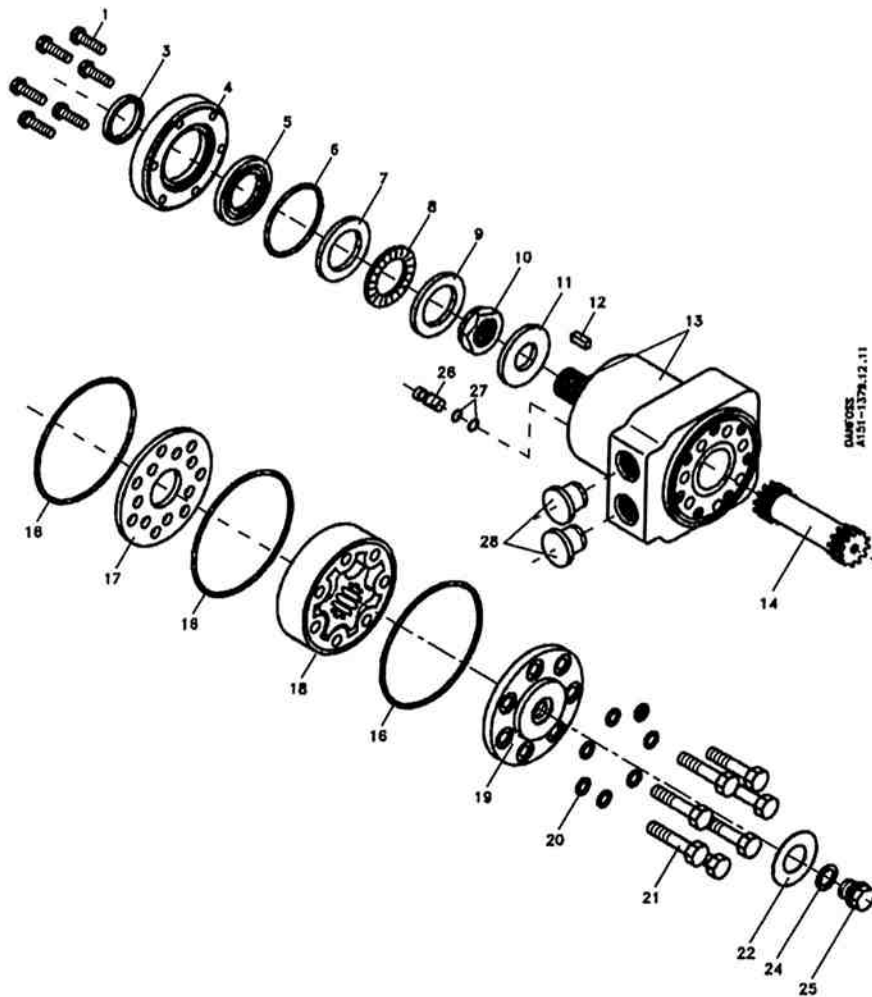

DANFOSS
A151-1379.12.11

Item	Spare parts	Dimension	Code no.	Number per motor					
				Series 8*	Series 7 and 8 with separate spigot flange				
				OMP Flange A2	OMP Flange A2	OMP C Flange A2	OMP Flange A4	OMP Flange C	OMPW OMPW N
1	<u>Screw</u>	M6: L = 16 mm M5: L = 16 mm M6: L = 16 mm	681X1989 681X1961 681X0247		6	6	6	6	6
3	<u>Dust seal ring</u> Ø25 mm, Ø1", 1" spl. shaft Ø25 mm, Ø1", 1" spl. shaft 28,5 mm tapered shaft Ø25 mm shaft Ø32 mm shaft,	35,0 × 27,5 × 2,2 mm 35,0 × 27,5 × 4,0 mm 35,0 × 28,5 × 4,0 mm 42,0 × 35,0 × 3,5 mm	633B0370 151-1313 633B0010 633B3198	1	1	1	1	1	1
4	<u>Spigot flange</u> Ø25 mm, Ø1", 1" spl. shaft (HPS) Ø25 mm, Ø1", 1" spl. shaft Ø25 mm shaft Ø25 mm shaft Ø25 mm, 28,5 mm tapered shaft Ø32 mm shaft, (HPS) Ø32 mm shaft		151-5588 151-5458 151-5473 151-1827 151-1978 151-5589 151-1734		1 1	1	1 1	1	1
5	<u>Shaft seal</u> Ø25 mm, Ø1", 1" spl. shaft (HPS) Ø25 mm, Ø1", 1" spl. 28,5 mm tapered shaft Ø25 mm, Ø1", 1" splined 28,5 mm tapered shaft Ø32 mm shaft, (HPS) Ø32 mm shaft,	39 × 28,6 × 4,9 mm, HSN 42,0 × 28,6 × 5,5 mm, NBR 42,0 × 28,6 × 5,5 mm, FPM 46 × 35 × 4,9 mm 48,0 × 35,0 × 5,5 mm, NBR	633B0414 633B3385 633B0323 633B0415 633B3273	1	1 1 1	1 1	1 1 1	1 1	1 1
6	<u>O-ring</u> Ø25 mm, Ø1", 1" spl. 28,5 mm tapered shaft Ø25 mm Ø32 mm shaft	47,2 × 3,5 mm, NBR 48,0 × 2,0 mm, NBR 53,0 × 2,0 mm, NBR	633B1191 633B1333 633B1528		1	1	1 1	1	1
7	<u>Bearing race</u> Ø25 mm, Ø1", 1" spl. shaft Ø25 mm, Ø1", 1" spl. shaft 28,5 mm tapered shaft Ø32 mm shaft	41,6 × 29 × 4 47,5 × 29,5 × 3,0 mm 47,5 × 29,5 × 3,3 mm 52,0 × 35,0 × 3,5 mm	151-5708 151-1608 151-1931 151-1701	1	1	1	1 1	1	1 1
8	<u>Axial needle bearing</u> Ø25 mm, Ø1", 1" spl. shaft Ø25 mm, Ø1", 1" spl. shaft 28,5 mm tapered shaft Ø32 mm shaft	42 × 28,7 × 4,5	151-5709 151-1458 981X0008 981X3198	1	1	1	1 1	1	1 1
9	<u>Bearing race</u> 28,5 mm tapered shaft Ø32 mm shaft	52,0 × 35,0 × 3,5 mm	151-1940 151-1701				1		1
10	<u>Castellated nut</u> 28,5 mm tapered shaft	M20 × 1,5	681X8202						1

NBR: (Buna N, Perbunan)

FPM: Viton (ISO 1629)

HPS: High pressure shaft seal

* Series 8 with integrated spigot flange

Item	Spare parts	Dimension	Code no.	Number per motor					
				Series 8*	Series 7 and 8 with separate spigot flange				
				OMP Flange A2	OMP Flange A2	OMP C Flange A2	OMP Flange A4	OMP Flange C	OMPW N
11	Washer for 28,5 mm tapered shaft	44,0 x 20,5 x 4,0	684X2530						1
12	Parallel key for Ø25 mm shaft	A8 x 7 x 32 mm, DIN 6885	682X8035	1	1		1	1	1
	for Ø25 mm shaft	A8 x 7 x 31 mm	682L9007			1			
	for Ø1" shaft	¼ x ¼ x 1¼ Inch, B.S.46	682X8036	1	1		1	1	
	for Ø32 mm shaft	A10 x 8 x 45 mm, DIN 6885	682X8019				1		
	for 28,5 mm tapered shaft	B5 x 5 x 14 mm, DIN 6885	682L8016						1
13	Housing + output shaft								
14	Cardan shaft								
	OMP 25	L = 73,8 mm	151-2690	1					
	OMP 25	L = 91,2 mm	151-5461		1				1
	OMP 32	L = 74,9 mm	151-2691	1					
	OMP 32	L = 92,3 mm	151-5460		1				
	OMP 40	L = 76,8 mm	151-2643	1					
	OMP 40	L = 94,0 mm	151-1787		1				
	OMP 50	L = 94,0 mm	151-1787		1		1	1	1
	OMP 50	L = 76,8 mm	151-2643	1		1			
	OMP 80	L = 98,0 mm	151-1788		1		1	1	1
	OMP 80	L = 80,7 mm	151-2644	1		1			
	OMP 100	L = 100,5 mm	151-1789		1		1	1	1
	OMP 100	L = 83,3 mm	151-2645	1		1			
	OMP 125	L = 100,5 mm	151-1789		1		1	1	1
	OMP 125	L = 87,1 mm	151-2646	1		1			
	OMP 160	L = 108,5 mm	151-1790		1		1	1	1
	OMP 160	L = 91,2 mm	151-2647	1		1			
	OMP 200	L = 113,5 mm	151-1791		1		1	1	1
	OMP 200	L = 96,4 mm	151-2648	1		1			
	OMP 250	L = 120,0 mm	151-1861		1		1	1	1
OMP 250	L = 102,9 mm	151-2649	1		1				
OMP 315	L = 128,5 mm	151-1792		1		1	1	1	
OMP 315	L = 111,4 mm	151-2650	1		1				
OMP 400	L = 139,5 mm	151-1793		1		1	1	1	
OMP 400	L = 122,6 mm	151-2651	1		1				
16	O-ring	75,9 x 1,8 mm, NBR	633B1173	3	3	3	3	3	3
17	Distributor plate		151-1713	1	1	1	1	1	1
18	Gear wheel set								
	OMP 25	W = 4,1 mm	151-1180	1	1				1
	OMP 32	W = 5,2 mm	151-1181	1	1				
	OMP 40	W = 6,5 mm	151-1188	1	1				
	OMP 50	W = 6,5 mm	151-1126	1	1	1	1	1	1
	OMP 80	W = 10,4 mm	151-1127	1	1	1	1	1	1
	OMP 100	W = 13,0 mm	151-1128	1	1	1	1	1	1
	OMP 125	W = 16,3 mm	151-1112	1	1	1	1	1	1
	OMP 160	W = 20,8 mm	151-1129	1	1	1	1	1	1
	OMP 200	W = 26,0 mm	151-1185	1	1	1	1	1	1
	OMP 250	W = 32,5 mm	151-1193	1	1	1	1	1	1
	OMP 315	W = 40,9 mm	151-1186	1	1	1	1	1	1
	OMP 400	W = 52,0 mm	151-1187	1	1	1	1	1	1

NBR: (Buna N, Perbunan)

FPM: Viton (ISO 1629)

HPS: High pressure shaft seal

* Series 8 with integrated spigot flange

Item	Spare parts	Dimension	Code no.	Number per motor					
				Series 8*	Series 7 and 8 with separate spigot flange				
				OMP Flange A2	OMP Flange A2	OMP C Flange A2	OMP Flange A4	OMP Flange C	OMPW OMPW N
19	<u>End cover</u> Side port motor without drain Side port motor End port motor		150-0328 151-1459 151-1832	1	1 1 1	1	1 1	1	1
20	<u>Washer</u> Side port motor End port motor	11,9 × 8,2 × 1,0 mm 11,9 × 8,2 × 1,0 mm	684X0076 684X0076	7	7 5	7	7	5	7
21	<u>Screw</u> <u>Side port motor</u> OMP 25 OMP 32 OMP40 OMP 50 OMP 80 OMP 100 OMP 125 OMP 160 OMP 200 OMP 250 OMP 315 OMP 400 <u>End port motor</u> OMP 50 OMP 80 OMP 100 OMP 160 OMP 200 OMP 250 OMP 315 OMP 400	M8 × 1,25 l = 30 mm l = 30 mm l = 35 mm l = 35 mm l = 40 mm l = 40 mm l = 45 mm l = 50 mm l = 55 mm l = 60 mm l = 70 mm l = 80 mm M8 × 1,25 l = 40 mm l = 45 mm l = 45 mm l = 55 mm l = 60 mm l = 65 mm l = 75 mm l = 85 mm	681X0238 681X0238 681X0179 681X0179 681X0180 681X0180 681X0181 681X0182 681X0183 681X0184 681X0186 681X0188 681X0180 681X0181 681X0181 681X0183 681X0184 681X0185 681X0187 681X0189	7 7 7 7 7 7 7 7 7 7 7 7 7 7 5 5 5 5 5 5 5 5	7 7 7 7 7 7 7 7 7 7 7 7 7 5 5 5 5 5 5 5	7 7 7 7 7 7 7 7 7 7 7 7 7 5 5 5 5 5 5	7 7 7 7 7 7 7 7 7 7 7 7 7 5 5 5 5 5 5	7 7 7 7 7 7 7 7 7 7 7 7 7 7 7 7 7 7 7	
22	<u>Name plate¹⁾</u> Side port motor - aluminium Side port motor - brass End port motor - aluminium		151A0411 151A0412 151A0417		1 1 1	1 1	1 1	1	1
24	Washer	17,5 × 13,5 × 1,5 mm	684X2120		1	1	1	1	1
25	Drain plug		151-1524		1	1	1	1	1
26	<u>Check valve incl. item 27</u> Only for OMP motors with built-in check valves		151-1076		2	2	2	2	2
27	O-ring	5,0 × 1,5 mm, NBR	633B1324		4	4	4	4	4
28	<u>Plug</u> Side port motor- plastic plug End port motor - steel plug End port motor - plastic plug		633X0074 631X9706 633X0074	2	2 2 2	2	2	2 2	2

NBR: (Buna N, Perbunan)

FPM: Viton (ISO 1629)

HPS: High pressure shaft seal

* Series 8 with integrated spigot flange

Item	Spare parts	Dimension	Code no.	Number per motor						
				Series 8*	Series 7 and 8 with separate spigot flange					
				OMP Flange A2	OMP Flange A2	OMP C Flange A2	OMP Flange A4	OMP Flange C	OMPW OMPW N	
	Spare part bag for motors with HPS and Ø25 mm, Ø1", 1" spl. shaft (Series 7/8)		151-1288	1						
3	1 pcs. Dust seal	35 x 27,5 x 2,2 mm NBR	633B0370							
5	1 pcs. Shaft seal (Series 7/8)	39 x 28,6 x 4,9 mm HSN	633B0414							
6	1 pcs. O-ring	47,2 x 3,5 mm NBR	633B1191							
6	1 pcs. O-ring	48 x 2 mm NBR	633B1333							
16	3 pcs. O-ring	75,9 x 1,8 mm NBR	633B1173							
16	3 pcs. O-ring	90 x 2 mm NBR	633B1301							
20	7 pcs. Washer	11,9 x 8,2 x 1 mm	684X0076							
	Spare parts bag for motors with standard shaft seal and Ø25 mm, Ø1", 1" spl. shaft 28,5 mm tapered shaft		151-1275		1	1**	1	1	1	
3	1 pcs. Dust seal	35 x 27,5 x 4 mm NBR	151-1313							
5	1 pcs. Shaft seal (Series 7/8)	42 x 28,6 x 5,5 mm NBR	633B3385							
5	1 pcs. Shaft seal (Series 6)	48 x 28,6 x 6 mm NBR	633B3209							
6	1 pcs. O-ring	47,2 x 3,5 mm NBR	633B1191							
6	1 pcs. O-ring	48 x 2 mm NBR	633B1333							
16	3 pcs. O-ring	75,9 x 1,8 mm NBR	633B1173							
20	7 pcs. Washer	11,9 x 8,2 x 1 mm	684X0076							
24	1 pcs. Washer	17,5 x 13,5 x 1,5 mm	684X2120							
	Spare part bag for motors with Ø35 mm shaft Series 6/7 and 8)		151-1179				1			
3	1 pcs. Dust seal	42 x 35 x 3,5 mm NBR	633B3198							
5	1 pcs. Shaft seal	48 x 35 x 5,5 mm NBR	633B3273							
6	1 pcs. O-ring	53 x 2 mm NBR	633B1528							
16	3 pcs. O-ring	75,9 x 1,8 mm NBR	633B1173							
20	7 pcs. Washer	11,9 x 8,2 x 1 mm	684X0076							
24	17,5 x 13,5 x 1,5 mm	17,5 x 13,5 x 1,5 mm	684X2120							

NBR: (Buna N, Perbunan) FPM: Viton (ISO 1629) HPS: High pressure shaft seal

* Series 8 with integrated spigot flange

** Excl. dust seal ring 633B0010

Tightening torque

Item	Code Number	Torque (daNm)	Torque (lbf in)
1	681X1989	0,5 - 0,8	45 - 70
	681X0247	0,5 - 0,8	45 - 70
	681X1961	0,5 - 1,0	45 - 90
10	681X8202	9,0 - 11,0	800 - 1000
21	-	3,0 - 3,5	270 - 315
25	-	3,0 - 6,0	270 - 540
28	631X9706	5,0 - 7,0	445 - 620

Special tools

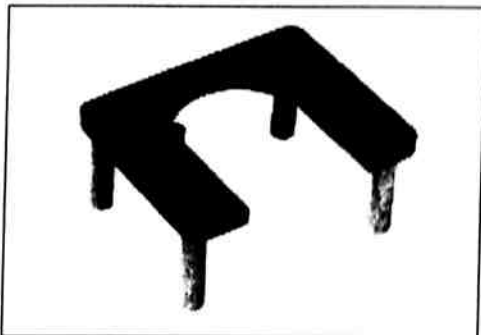

Main holding tool (horse hole):
Code No.: SJ 151-9000-1.



Fork. For use when fitting OMP cardan shaft.
Code No.: SJ 150-9000-3.

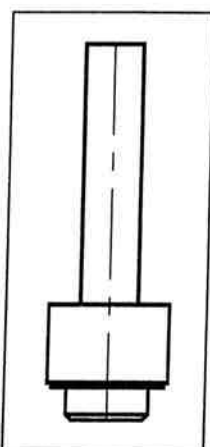

Mandrel: Code No.:
SJ 151-0414

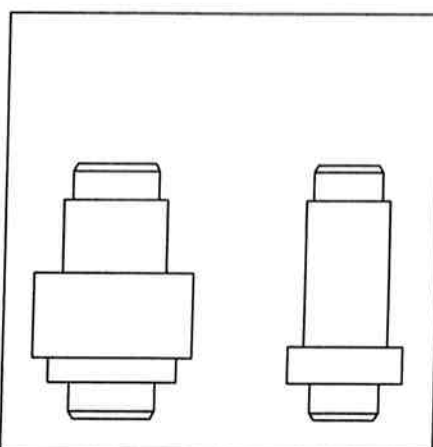

Mandrel: Code No.:
SJ 151-9000-7 or
SJ 151F9000-7

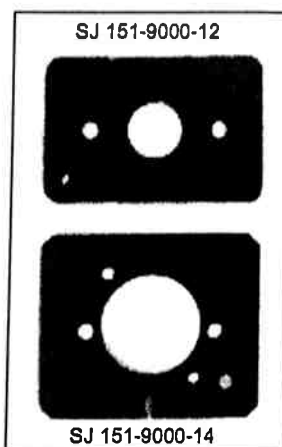

SJ 151-9000-12
Holding tool for motor with
square mounting flange:
Code No.: SJ 151-9000-12.
Holding tool for OMPW N.
Code No.: SJ 151-9000-14.

Dismantling

Item	Part to remove	Comments
10	Castelated nut	
11	Washer	
12	Parallel key	
28	Seal plugs	<p>Placer motor i holdeværktøj med udgangsaksel nederst. Ved endeportsversion benyttes 10 mm unbrakonøgle.</p> <p>Put the motor in a holding tool, with the output shaft downward. For end port version use 10 mm hexagon socket spanner.</p> <p>Den Motor mit der Abtriebswelle nach unten im Haltewerkzeug anbringen. Bei der Ausführung mit Endanschlüssen 10 mm Sechskantstiftschlüssel verwenden.</p> <p>Placer moteur dans l'outil arbre de sortie vers le bas. Pour la version avec orifice à l'arrière, utiliser une clé Allen de 10 mm.</p>
25, 24	Drain plug, washer (If present)	<p>Benyt 19 mm topnøgle. Use a 19 mm spanner socket. Einen 19 mm Steckschlüssel verwenden Utiliser clé à douille 19 mm.</p>

Dismantling

Item	Part to remove	Comments
21, 20	Screws, washers	Benyt 13 mm topnøgle. Use a 13 mm spanner socket. Einen 13 mm Steckschlüssel verwenden. Utilisez clé à douille 13 mm.
19	End cover	Fjern endedækslet sideværts. Remove end cover sideways. Den Enddeckel seitwärts entfernen. Enlever le couvercle latéralement.
18, 16	Gear wheel set O-rings (2 off)	Hold fingrene under tandhjulssættet for at forhindre delene i at falde ud. Keep fingers under the gearwheel set to prevent the parts from falling out. Die Finger unter dem Zahnradsatz halten, um zu verhindern, daß Teile herausfallen. Tenir le jeu d'engrenages par dessous pour ne pas perdre de pièces.
14	Cardan shaft	
17, 16	Distributor plate O-ring	
13	Output shaft	<p><u>Motorer med integreret styreflange:</u> Motorhus placeres på arbejdsbord og akslen presses ud af motorhuset. Akslen og lejer bør normalt ikke tages ud af OMPW N. Ønskes dette alligevel for inspektion og rengøring, føres akslen bag ud af huset ved slag med en plasthammer på akseltappen. Det forreste leje, kan derved forblive i huset. Vend herefter motoren.</p> <p><u>Motors with integrated spigot flange:</u> Place the motor housing on the work bench and press the shaft out of the motor housing. Shaft and bearings should normally not be removed from OMPW N. However, if necessary for inspection and cleaning, remove the shaft from the back of the housing by gently tapping the axle journal with a plastic hammer. The front bearing can thus remain in the housing. After this, turn the motor.</p> <p><u>Motoren mit integriertem Dichtungsflansch:</u> Das Motorgehäuse auf dem Arbeitstisch legen und die Welle aus dem Motorgehäuse pressen. Welle und Lager sollten normalerweise nicht von OMPW N entfernt werden. Wenn aber notwendig zwecks Inspektion und Reinigung, mit leichten Schlägen eines Kunststoffhammers auf den Wellenzapfen die Welle rückwärts aus dem Gehäuse führen. Das vordere Lager kann somit im Gehäuse bleiben. Hiernach den Motor wenden.</p> <p><u>Moteur avec plaque porte joint intégrée:</u> Placer le carter moteur sur l'établi et poussez sur l'arbre pour la faire sortir du carter moteur. Normalement, il ne faut pas enlever l'arbre et les paliers de l'OMPW N, mais au besoin, pour permettre l'inspection et le nettoyage, faire sortir l'arbre du carter par l'arrière en frappant légèrement sur le tourillon d'arbre avec un marteau plastique. Le palier devant peut ainsi rester dans le carter. Retourner ensuite le moteur.</p>

Dismantling

Item	Part to remove	Comments
1	Screws (6 off) (If present)	<p>Anvend Torx-nøgle type T30, 9 mm skruetrækker eller 4 mm unbrakonøgle.</p> <p>Use Torx-spanner type T30, 9 mm screwdriver or 4 mm hexagon socket spanner.</p> <p>Werkzeug: Torx-Schlüssel Typ T30, 9 mm Schraubenzieher oder 4 mm Sechskant Schlüssel.</p> <p>Utiliser: Clé Torx type T30, tournevis de 9 mm ou clé 'Allen de 4 mm.</p>
4	Spigot flange	
6, 7	O-ring, bearing race	<p><u>Motorer med integreret styreflange:</u> Fjern leje og løbeskive fra motorhuset. <u>Motorer med separat styreflange:</u> Anvend 2 mm skruetrækker.</p> <p><u>Motors with integrated spigot flange:</u> Remove bearing and bearing race from the motor housing. <u>Motors with separate spigot flange:</u> Use a 2 mm screwdriver.</p> <p><u>Motoren mit integriertem Dichtungsflansch:</u> Lager und Scheibe aus dem Motorgehäuse entfernen. <u>Motoren mit separatem Dichtungsflansch:</u> Einen 2 mm Schraubenzieher verwenden.</p> <p><u>Moteur avec plaque porte joint intégrée:</u> Retirer les butées et la butée à billes du carter moteur. <u>Moteur avec plaque porte joint séparée:</u> Utiliser un tournevis de 2 mm.</p>
8	Needle bearing	
5 3	Shaft seal Dust seal	<p><u>Motorer med integreret styreflange:</u> Slå pakdåsen forsigtigt ud med dorn og plasthammer.</p> <p><u>Motorer med separat styreflange:</u> Slå akselpakning / Støvtætningsring ud med plasthammer. Brug dorn SJ 151-9000-7 eller SJ 151F9000-7.</p> <p><u>Motors with integrated spigot flange:</u> With mandrel and plastic hammer, carefully knock out the shaft seal.</p> <p><u>Motors with separate spigot flange:</u> Knock out the shaft seal / dust seal with a plastic hammer. Use mandrel SJ 151-9000-7 or SJ 151F9000-7.</p> <p><u>Motoren mit integriertem Dichtungsflansch:</u> Die Dichtung vorsichtig mit Dorn und Plasthammer herausschlagen</p> <p><u>Motoren mit separatem Dichtungsflansch:</u> Die Wellendichtung / Staubbichtung mit Kunststoffhammer herausschlagen. Verwenden Sie Dorn SJ 151-9000-7 oder SJ 151F9000-7.</p> <p><u>Moteur avec plaque porte joint intégrée:</u> A l'aide d'un marteau en plastic et d'un emporte-pièce, chassez délicatement le joint d'arbre</p> <p><u>Moteur avec plaque porte joint séparée:</u> Faites sortir les joint d'arbre/anti-poussière à l'aide d'un marteau plastique. Utilisez l'outil SJ 151-9000-7 ou SJ 151F9000-7.</p>

Dismantling

Item	Part to remove	Comments
9	Bearing race	<p>Kun OMP/OMPW N med Ø32mm/28,5 mm konisk aksel. Anvend 2 mm skruetrækker.</p> <p>Only OMP/OMPW N with Ø32 mm/28,5 mm tapered shaft. Use a 2 mm screwdriver.</p> <p>Nur OMP/OMPW N mit Ø32 mm/28,5 mm kegelige Welle. Einen 2 mm Schraubenzieher verwenden.</p> <p>Seulement OMP/OMPW N avec Ø32 mm/arbre conique de 28,5 mm. Utiliser tournevis de 2 mm.</p>
26	Check valves (2 off)	<p><u>Kun OMP med kontraventiler</u> Træk kontraventilerne ud med fx en nedsløbet (afkortet) 3,5 mm snittap.</p> <p><u>Only OMP with check valves</u> Pull the check valve out with, for example, a ground (shortened) 3.5 mm screw tap.</p> <p><u>Nur OMP mit Rückschlagventilen</u> Die Rückschlagventile herausziehen, z.B. mit einem abgeschliffenen (verkürzten) 3,5 mm Gewindebohrer.</p> <p><u>Seulement OMP avec des clapets anti-retour</u> Pour les sortir, utiliser par ex. un taraud 3,5 mm (raccourci).</p>

Rensning

Rengør omhyggeligt alle dele i aromatfattig petroleum.

Kontrol og udskiftning

Kontroller omhyggeligt alle dele og skift dem ud hvis nødvendigt.

Smøring

Smør alle enkeltdele ind i hydraulikolie før samling og indfædt gummidele med vaseline.

Cleaning

Clean all parts carefully with low aromatic kerosine.

Inspection and replacement

Check all parts carefully and replace if necessary.

Lubrication

Before assembly, lubricate all parts with hydraulic oil and grease rubber parts with vaseline.

Reinigung

Alle Teile sorgfältig in aromatarmem Petroleum reinigen.

Kontrolle und Auswechslung

Alle Teile sorgfältig kontrollieren und falls notwendig, auswechseln.

Schmieren

Alle Einzelteile vor der Montage mit Hydrauliköl einschmieren, und die Gummiteile mit Vaseline einfetten.

Nettoyage

Nettoyer soigneusement toutes les pièces dans du pétrole à faible teneur en additifs.

Vérification et remplacement

Vérifier soigneusement toutes les pièces et les remplacer s'il y a lieu.

Lubrification

Avant le remontage, enduire toutes les pièces d'huile hydraulique, et graisser les pièces de caoutchouc avec de la vaseline.

Assembly

Item	Part to mount	Comments
		<p>Placer motorhuset i holdeværktøjet med flangen øverst. Place the motor housing in the holding tool with the flange upwards. Das Motorgehäuse mit dem Flansch nach oben im Haltewerkzeug anbringen. Placer le carter du moteur dans l'outil, bride vers le haut.</p>
26	Check valves (2 off)	<p><u>Kun OMP med kontraventiler</u> Indfædt kontraventillerne (med nye O-ringe) og monter dem i borerne med lette slag af en plasthammer.</p> <p><u>Only OMP with check valves</u> Grease the check valves (fitted with new O-rings) and fit them in their bores with light blows using plastic hammer.</p> <p><u>Nur OMP mit Rückschlagventilen</u> Rückschlagventile (mit neuen O-Ringen) einfetten und mit leichten Schlägen mit einem Kunststoffhammer in den Bohrungen anbringen.</p> <p><u>Seulement OMP avec des clapets anti-retour</u> Enduire de graisse les clapets anti-retour avec nouveaux joints torques et les mettre en place dans les alésages en tapant légèrement avec un marteau plastique.</p>
9	Bearing race	<p>Kun OMP/OMPW N med Ø32mm/28,5 mm konisk aksel. Only OMP/OMPW N with Ø32 mm/28,5 mm tapered shaft. Nur OMP/OMPW N mit Ø32 mm/28,5 mm kegelige Welle. Seulement OMP/OMPW N avec Ø32 mm/arbre conique de 28,5 mm.</p>
5	Shaft seal	<p><u>Motorer med integreret styreflange:</u> Smør pakdåsen med hydraulikolie indvendig og udvendig. Placer pakdåsen korrekt på montagedorn SJ 151-0414 og pres den for sigtig på plads i motorhuset.</p> <p><u>Motorer med separat styreflange:</u> Slå pakningen på plads i styreflengen. Kontroller at pakningen lægger an mod dækslets reces. Brug dorn SJ 151-9000-7 eller SJ 151F9000-7.</p> <p><u>Motors with integrated spigot flange:</u> Lubricate the shaft seal on the out side with hydraulic oil. Fit the shaft seal correct onto mandrel SJ 151-0414 and carefully press the shaft seal into position in the motor housing.</p> <p><u>Motors with separate spigot flange:</u> Knock the seal into position in the spigot flange. Check that the seal lies against the cover recess. Use mandrel SJ 151-9000-7 or SJ 151F9000-7.</p> <p><u>Motoren mit integriertem Dichtungsflansch:</u> Die Wellendichtung mit Hydrauliköl auf Innen- und außenseite schmieren. Die Dichtung korrekt auf Dorn SJ 151-0414 anbringen und vorsichtig an ihren Platz im Motorgehäuse drücken.</p> <p><u>Motoren mit separatem Dichtungsflansch:</u> Die Dichtung im Steuerflansch an ihren Platz schlagen. Kontrollieren, ob die Dichtung an der Vertiefung des Deckels anliegt. Verwenden Sie Dorn SJ 151-9000-7 oder SJ 151F9000-7.</p> <p><u>Moteur avec plaque porte joint intégrée:</u> Lubrifier le joint d'arbre sur sa contour extérieur avec de l'huile hydraulique. Positionnez-le sur correctement l'outil SJ 151 0414 et positionnez délicatement le joint d'arbre dans le carter moteur.</p> <p><u>Moteur avec plaque porte joint séparée:</u> Placer le joint dans la bride de centrage et taper pour le mettre en place; s'assurer qu'il est blotti dans le recès. Utiliser pointeau SJ 151-9000-7 ou SJ 151F9000-7.</p>

Assembly

Item	Part to mount	Comments
3	Dust seal ring	<p>Anbring støvtætningsringen i styreflansen og bank den på plads med en plasthammer og passende dorn. SJ 151-9000-7 eller SJ 151F9000-7.</p> <p>Place the dust seal ring in the spigot flange and knock it into position with a plastic hammer and appropriate mandrel. SJ 151-9000-7 or SJ 151F9000-7.</p> <p>Den Staubdichtungsring im Steuerflansch anbringen und mit einem Kunststoffhammer und passendem Dorn an seinen Platz schlagen. SJ 151-9000-7 oder SJ 151F9000-7.</p> <p>Placer le joint anti-poussière dans bride de centrage et le taper en place avec marteau plastique et pointeau adéquat. SJ 151-9000-7 ou SJ 151F9000-7.</p>
7, 6	Bearing race, O-ring	<p><u>Motors med integreret styreflange:</u> Leje og løbeskive placeres på akslen og monteres sammen med denne.</p> <p><u>Motors med separat styreflange:</u> Indfædt O-ring i vaseline og monter løbeskiven og O-ringen i styreflansen.</p> <p><u>Motors with integrated spigot flange:</u> Fit bearing and bearing race onto the shaft and mount together with the shaft.</p> <p><u>Motors with separate spigot flange:</u> Grease the O-ring with vaseline and fit the bearing race and O-ring into the spigot flange.</p> <p><u>Motoren mit integriertem Dichtungsflansch:</u> Lager und Scheibe auf die Welle platzieren und zusammen einbauen.</p> <p><u>Motoren mit separatem Dichtungsflansch:</u> O-Ring mit Vaseline einfetten und Laufscheibe und O-Ring im Zentrierflansch montieren.</p> <p><u>Moteur avec plaque porte joint intégrée:</u> Monter les butées et la butée à billes sur l'arbre et monter l'ensemble dans le carter moteur.</p> <p><u>Moteur avec plaque porte joint séparée:</u> Enduire le joint torique de vaseline et monter la butée à billes et le joint torique dans la plaque porte joint.</p>
8	Needle bearing	
4	Spigot flange	<p>Drej så hullerne flugter. Turn so that the holes line up. So drehen, daß die Löcher fluchten. Ajuster pour aligner les trous.</p>

Assembly

Item	Part to mount	Comments
1	Screws (6 off)	<p><i>Tilspændingsmoment</i> Torx skruer M6 : 0,5-0,8 daNm Kærviskruer M6 : 0,5-0,8 daNm Unbrakoskruer M5: 0,5-1,0 daNm</p> <p>Vend herefter motoren.</p> <p><i>Tightening torque</i> Torx screws M6 : 0,5-0,8 daNm(45-70 lbf in (in-lbs)) Slotted screws M6 : 0,5-0,8 daNm (45-70 lbf in (in-lbs)) Hexagon socket screws M5: 0,5-1,0 daNm (45-70 lbf in (in-lbs))</p> <p>After this, turn the motor.</p> <p><i>Anzugsmoment</i> Torx Schrauben M6 : 0,5-0,8 daNm Schlitzschrauben M6 : 0,5-0,8 daNm Sechskantstift-Schrauben M5: 0,5-1,0 daNm</p> <p>Hiernach den Motor wenden.</p> <p><i>Couple de serrage</i> vis Torx M6 : 0,5-0,8 daNm vis à encoche M6: 0,5-0,8 daNm vis Allen M5 : 0,5-1,0 daNm</p> <p>Retourner ensuite le moteur.</p>
13	Output shaft	<p>Akselsølerne smøres med hydraulikolie. På akselenden skal der markeres et punkt lodret over et kommu- teringsspor der har forbindelse til forreste ringkanal. Akslen på OMPW N føres bagfra ind i motorhuset med det bagerste nåleleje monteret på akslen. Slå med lette slag med plashammer på akslen til den flugter med husets bagside. Kontroller at akslen nemt drejer rundt.</p> <p>Grease the journals with hydraulic oil. The rear shaft end must be marked before fitted. The mark must be positioned vertically above a commutation slot leading up to the front annular channel. For OMPW N, guide the shaft into the motor housing back with the rear needle bearing fitted on the shaft. Bring the shaft in line with the back of the motor by gently tapping the shaft with a plastic hammer. Check that the shaft rotates easily</p> <p>Die Gleitlager mit Hydrauliköl einschmieren. Am Wellenende muß senkrecht über eine Kommutierungsritze, die Verbindung mit dem vorderen Ringkanal hat, eine Markierung gemacht werden. Bei OMPW N, die Welle von hinten in das Gehäuse einführen, indem das hintere Nadellager auf der Welle montiert ist. Der Welle leichte Schläge eines Kunststoffhammers zufügen, um sie mit der Rückseite des Gehäuses zu fluchten zu bringen. Kontrollieren, daß die Welle unbehindert dreht.</p> <p>Enduire les tourillons de l'huile pour systèmes hydrauliques. Pour arbres marquer au bout de l'arbre arrière la position qui se trouve verticalement à une voie de commutation liée au canal annulaire placé en tête. Pour l'OMPW N, faire entrer l'arbre par l'arrière dans le carter du moteur, la butée à aiguilles arrière étant montée sur l'arbre. Faire affleurer l'arbre et l'arrière du carter en frappant légèrement sur l'arbre avec un marteau plastique. Vérifier que l'arbre tourne facilement.</p>

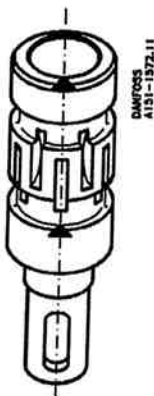

Assembly

Item	Part to mount	Comments
16	O-ring	<p>Indfædt O-ring og læg den i husets O-ringsrille.</p> <p>Grease the O-ring and put it in the O-ring groove of the housing.</p> <p>Den O-Ring einfetten und in die O-Ring-Rille des Gehäuses legen.</p> <p>Graisser le joint et le placer dans sa rainure dans le carter.</p>
17	Distributor plate	<p>Drej fordelerpladen, så hullerne flugter.</p> <p>Turn the distributor plate so that the holes line up.</p> <p>Die Verteilerplatte so drehen, daß die Löcher fluchten.</p> <p>Ajuster la plaque de distribution pour aligner les trous.</p>
14	Cardan shaft	<p>Før kardanakslen ned i motorhuset.</p> <p><u>Kun OMP 25, 32, 40</u></p> <p>Anbring monteringsgafflen under kardanakslens øverste tænder.</p> <p>Når der er forskel på splinelængden, vendes kardanakslen således, at den lange splinende monteres i udgangsakslen.</p> <p>Overfør markering fra udgangsaksel til kardanaksel.</p> <hr/> <p>Guide the cardan shaft down into the motor housing.</p> <p><u>Only OMP 25, 32, 40</u></p> <p>Place the assembly tool under the upper splines of the cardan shaft.</p> <p>In case of different splines lengths turn the cardan shaft to ensure the long splines end is fitted in the output shaft.</p> <p>Transfer marking from output shaft to cardan shaft.</p> <hr/> <p>Kardanwelle in das Motorgehäuse einführen.</p> <p><u>Nur OMP 25, 32, 40</u></p> <p>Die Montagegabel unter die oberen Verzahnung der Kardanwelle anbringen.</p> <p>Bei unterschiedlichen Verzahnungslängen ist die Kardanwelle so zu richten, daß lange Verzahnungsendstück in der Abtriebswelle montiert wird.</p> <p>Die Markierung von der Abtriebswelle auf die Kardanwelle übertragen.</p> <hr/> <p>Glisser l'arbre à cardan dans le carter du moteur.</p> <p><u>Seulement OMP 25, 32, 40</u></p> <p>Monter la fourche de montage sous les cannelures supérieures de l'arbre à cardan.</p> <p>Si les cannelures sont différentes de longueur, tourner l'arbre à cardan de façon que l'extrémité cannelée la plus longue est montée dans l'arbre de sortie.</p> <p>Reporter le marquage de l'arbre de sortie à l'arbre à cardan.</p>

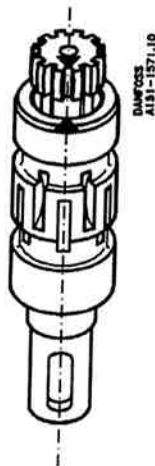

Assembly

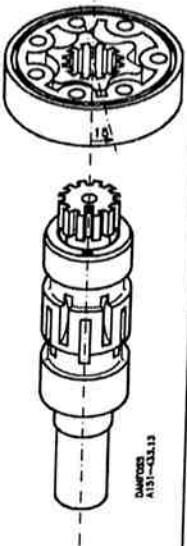
Item	Part to mount	Comments
18, 16	Gearwheel set, O-rings	<p>Placer O-ringene (Indfædtet) i tandkransens O-ringsriller.</p> <p>I de tandhjul hvor splines ikke er gennemgående, vendes tandhjulet så fridrejning vender ned mod huset.</p> <p>Placer tandhjulsættet på kardanakslen, så en tandtop i tandhjulets udvendige fortanding er lodret over mærket på kardanakslen.</p> <p>Drej tandhjulsættet mod uret indtil kardanakslen og tandhjul går i indgreb (15°). Drej tandkransen, så hullerne til skrueerne flugter.</p>
		<p>Place the O-rings (greased) in the O-ring grooves of the gearwheel.</p> <p>In gearwheels with non through splines place the gearwheel with the recess in the spline hole facing down towards the housing.</p> <p>Place the gearwheel set on the cardan shaft so that the top of a tooth in the external teeth of the gearwheel are vertically above the mark on the cardan shaft.</p> <p>Turn the gearwheel set counter clockwise until the cardan shaft and the gearwheel start to mesh (15°). Turn the gearwheel rim so that the holes made for the screws line up.</p>
		<p>Die O-Ringe (eingefettet) in den O-Ring-Rillen des Zahnkranzes anbringen.</p> <p>Einen Zahnradsatz mit Zahnrad ohne durchgehende Verzahnung so wenden daß die Seite ohne Verzahnung gegen das Motorgehäuse gekehrt ist.</p> <p>Den Zahnradsatz so auf der Kardanwelle anbringen, daß sich ein Zahnkopf in der Aussenverzahnung des Zahnrads senkrecht über der Markierung der Kardanwelle befindet.</p> <p>Den Zahnradsatz gegen den Uhrzeigersinn drehen, bis Kardanwelle und Zahnrad im Eingriff sind (15°).</p> <p>Den Zahnradkranz drehen, bis die Schraubenlöcher fluchten.</p>
		<p>Placer les joints toriques (graissés) dans leurs rainures dans la couronne dentée.</p> <p>Si les cannelures ne sont pas du type traversant, orienter la roue dentée avec la gorge de dégagement contre le carter.</p> <p>Placer le jeu d'engrenages sur l'arbre à cardan de façon à ce qu'un sommet de dent de la denture extérieure du rotor se trouve au-dessus de la rainure dans l'arbre a cardan.</p> <p>Tourner le jeu d'engrenages en sens inverse d'horloge jusqu'à engagement de l'arbre à cardan dans la roue dentée (15°).</p> <p>Tourner la couronne dentée pour faire aligner les trous à vis.</p>
19	End cover	<p>Drej endedækslet så hullerne flugter.</p> <p>Turn the end cover so that the holes line up.</p> <p>Den Enddeckel so drehen, daß die Löcher fluchten.</p> <p>Tourner le couvercle pour faire aligner les trous.</p>

Assembly

Item	Part to mount	Comments
20, 21	Washer, screws	<p>Benyt 13 mm topnøgle. Tilspændingsmoment: 3,0-3,5 daNm.</p> <p>Use a 13 mm spanner socket Tightening torque: 3,0-3,5 daNm (265-310 lbf in (in-lbs)).</p> <p>Den 13 mm Steckschlüssel verwenden. Anzugsmoment: 3,0-3,5 daNm.</p> <p>Utiliser clé à douille de 13 mm. Couple de serrage: 3,0 à 3,5 daNm.</p>
24, 25	Washer, drain plug (if present)	<p>Benyt 19 mm topnøgle. Tilspændingsmoment: $\frac{7}{16}$-20 UNF: $3 \pm 0,5$ daNm. R $\frac{1}{4}$" : $4,5 \pm 1,5$ daNm.</p> <p>Use a 19 mm spanner socket. Tightening torque: 3-6 daNm (265-536 lbf in).</p> <p>Den 19 mm Steckschlüssel verwenden. Anzugsmoment: 3-6 daNm.</p> <p>Utiliser clé à douille 19 mm. Couple de serrage: 3 à 6 daNm.</p>
28	Seal plugs Threaded plug	<p><i>Endeportsversion</i> Skrue plastpropper i endeportene. Skrue propperne i sideportene med 10 mm unbrakonøgle. Tilspændingsmoment: 5-7 daNm. <i>Sideportsversion:</i> Skru plastpropper i.</p> <p><i>End port version:</i> Screw plastic plugs into end ports. Screw in the side port plugs using 10 mm hexagon socket spanner. Tightening torque: 5-7 daNm (445-620 lbf in (in-lbs)).</p> <p><i>Side port version</i> Screw in plastic plugs.</p> <p><i>Ausgabe mit Endanschlüssen</i> Kunststoffstopfen in die Endanschlüsse einschrauben. Stopfen in die Seitenanschlüsse mit 10 mm Sechskantstiftschlüssel einschrauben. Anzugsmoment: 5-7 daNm.</p> <p><i>Ausgabe mit Seitenanschlüssen:</i> Kunststoffstopfen einschrauben.</p> <p><i>Version avec orifice à l'arrière</i> Visser les bouchons dans les orifices arrière. Visser les bouchons dans les orifices latéraux avec une clé Allen de 10 mm.</p> <p><i>Version avec orifices latéraux:</i> Visser les bouchons en place.</p>
12	Parallel key	<p>Sikres med tape eller plastring. To be secured with tape or plastic ring. Mit Tape oder Kunststoffring sichern. Attacher avec du scotch ou un anneau en matière plastique.</p>
11	Washer	
10	Castelated nut	