

Operating instructions

For responsible bodies and persons using the machine

Pipe Cutting and Beveling Machines

GF 4, GF 6 (AVM/MVM)

GF 20 AVM

**RA 2, RA 8, RA 12
(AVM/MVM)**



Machine no.:

.....
.....

Translation of original
operating instructions
Code 790 142 766 | EN



To work safely with this machine, please read through the operating instructions in full before initial operation.
Retain the operating instructions for future reference.

TABLE OF CONTENTS

1.	About these instructions	5	5.1	Pipe Cutting and Beveling Machines	26
1.1	Warning messages	5	5.2	Line laser	27
1.2	Further symbols and displays	5	6.	Initial operation	28
1.3	Abbreviations	6	6.1	Checking the parts of delivery	28
2.	Information and safety instructions for the responsible body	7	6.2	Included with the machine.....	28
2.1	Requirements for the responsible body.....	7	7.	Storage and transport	29
2.2	Using the machine	7	7.1	Storage.....	29
2.2.1	Proper use	7	7.1.1	Position of the cutter in the transport case	29
2.2.2	Improper use	7	7.2	Transport.....	29
2.2.3	Machine constraints.....	7	7.2.1	Transporting the GF 4, GF 6, RA 2, RA 8 (AVM/MVM)	30
2.2.4	Shutting down the machine.....	8	7.2.2	Transporting the GF 20 AVM	30
2.3	Environmental protection/disposal.....	8	7.2.3	Transporting the RA 12	30
2.3.1	Chips and gear lubricant oil	8	8.	Setup and assembly.....	31
2.3.2	Electric tools and accessories	8	8.1	Mounting the pipe cutter on the workbench.....	31
2.3.3	Returning batteries	8	8.1.1	Mounting the quick-mounting plate on the workbench	31
2.4	Basic safety instructions.....	9	8.1.2	Mounting the pipe cutter on the quick-mounting plate.....	31
2.5	Warning symbols	12	8.1.3	Pipe feeder (base and extension unit, mobile workstation)	32
3.	Product design.....	13	8.2	GF 4 and GF 6: fitting the clamping jaws....	32
3.1	Pipe Cutting and Beveling Machine GF 4 ...	13	8.2.1	Fitting the clamping jaws.....	33
3.2	Pipe Cutting and Beveling Machine GF 6 ...	14	8.3	Fitting the saw blade, bevel cutter, additional cutters.....	33
3.3	Pipe Cutting and Beveling Machine GF 20 AVM	15	8.3.1	Inserting the saw blade or bevel cutter	34
3.4	Pipe Cutting and Beveling Machines RA 2, RA 8, RA 12	16	8.3.2	Inserting the saw blade/bevel cutter combination.....	34
3.5	Automatic Feed Module AVM	16	8.4	Adjusting the pipe dimension	35
3.5.1	Description of the AVM buttons	17	8.4.1	Saw blade without additional cutter.....	35
3.6	Manual Feed Module MVM	17	8.4.2	Saw blade with additional cutter.....	36
3.7	Accessories	18	8.4.3	Adjusting the bevel cutter.....	37
3.7.1	Saw blades and bevel cutters	18	8.5	Selecting the motor speed.....	38
3.7.2	Aluminum clamping shells.....	18	8.5.1	Standard values for spindle speed and feed force level (AVM).....	38
3.7.4	Special high quality stainless steel clamping jaws	19	9.	Operation	39
3.7.5	Set of stainless steel caps	19	9.1	Processing the pipe with AVM.....	40
3.7.6	Quick-mounting plate with screw clamps ..	19	9.1.1	Shutting down (even in an emergency)....	40
3.7.7	Special gear oil	19	9.1.2	Initial operation	41
3.7.8	Saw blade lubricant GF TOP	19	9.1.3	Cutting the pipe with AVM	41
3.7.9	Saw blade lubricant GF LUB	20	9.1.4	Beveling the pipe with AVM	42
3.7.10	Continuous cooling system.....	20	9.1.5	Cutting and beveling pipes simultaneously	42
3.7.11	Aluminum clamping shells for GF 20 AVM..	20	9.2	Processing the pipe with MVM.....	43
3.7.12	Cutting lubrication KSS-TOP	21	9.2.1	Shutting down (even in an emergency)....	43
3.7.13	Warning symbols	21	9.2.2	Cutting the pipe with MVM	43
4.	Features and scope of application.....	22	9.2.3	Beveling the pipe with MVM	44
4.1	Features	22			
4.2	Additional properties of the GF 4 and GF 6 (AVM/MVM)	23			
4.3	Scope of application	25			
4.3.1	Working range	25			
4.3.2	Materials	25			
5.	Technical data.....	26			

9.2.4	Cutting the pipe with MVM and beveling it simultaneously	45
9.3	Processing the pipe manually	46
9.3.1	Shutting down (even in an emergency).....	46
9.3.2	Cutting the pipe manually	46
9.3.3	Beveling the pipe manually	47
9.3.4	Cutting the pipe manually and beveling it simultaneously	48
10.	Continuous cooling system for the GF 20 AVM	49
10.1	Features	49
10.2	Position of the cooling system on the GF 20 AVM	49
10.3	Product design.....	50
10.4	Assembly.....	50
11.	Servicing, maintenance, troubleshooting.....	52
11.1	Maintenance	52
11.1.1	Laser	52
11.2	Checking the oil level of the gear and topping up	53
11.3	Cleaning the slide guide	53
11.4	Mounting instruction for laser/ Change of batteries.....	54
11.4.1	GF 4, GF 6 (AVM/MVM).....	54
11.5	What to do if? – General trouble-shooting	54
11.5.1	What to do in the event of tool breakage ...	55
11.6	Error messages/trouble-shooting AVM	55
11.7	Servicing/customer service	56
12.	EU declaration of conformity.....	57
12.1	GF 4, GF 6, RA 2, RA 8, RA 12 (Standard/MVM)	57
12.2	GF 4 AVM, GF 6 AVM, RA 8 AVM, RA 12 AVM	58
12.3	GF 20 AVM	59

1. ABOUT THESE INSTRUCTIONS

To allow quick understanding of these instructions and safe handling of the machine, all the warning messages, notes and symbols used in these instructions are presented here along with their meaning.

1.1 Warning messages

In these instructions, warning messages are used to warn you against the dangers of injury or material damage. Always read and observe these warning messages!



This is a warning symbol. It should warn you against dangers of injury. Follow all instructions which are identified with this safety symbol in order to avoid injuries or death.

Warning symbol Meaning



DANGER

Direct danger!
Non-observance could result in death or critical injury.
⊖ Restrictions (if applicable).
▶ Measures to prevent danger.



WARNING

Possible danger!
Non-observance could result in serious injury.
⊖ Restrictions (if applicable).
▶ Measures to prevent danger.



ATTENTION

Dangerous situation!
▶ Non-observance could result in minor injuries.

ATTENTION

Dangerous situation!
▶ Non-observance could result in material damage.

1.2 Further symbols and displays

Symbol

Meaning

IMPORTANT
NOTE

Notes: Contain particularly important information for comprehension.



Instruction: You must take notice of this symbol.

1.

Request for action in a sequence of actions: You have to do something here.



Single request for action: You have to do something here.



Conditional request for action: You have to do something here if the specified condition is met.

1.3 Abbreviations

Abbr.	Meaning
GF, RA	Pipe cutting and beveling machines
AVM	Automatic Feed Module
MVM	Manual Feed Module

2. INFORMATION AND SAFETY INSTRUCTIONS FOR THE RESPONSIBLE BODY

2.1 Requirements for the responsible body

Workshop/outdoor/field application: The responsible body is responsible for safety in the danger zone around the machine, and should allow only qualified personnel to enter the zone or operate the machine in the danger zone.

Employee safety: The safety regulations described in chap. 2, p. 7 must be observed and work must be carried out with safety in mind using the prescribed protective equipment.

2.2 Using the machine

2.2.1 Proper use

- The machine is to be used solely for processing (cutting and beveling) materials, as specified in chap. 4.3.2, p. 25, with an outer pipe diameter of a max. of 508 mm (20 inch) (application range, see chap. 4.3.1, p. 25).
- The machines must only be operated using the voltage levels specified on the drive identification plate and in the "technical data" (see chap. 5, p. 26).
- The Automatic and Manual Feed Module AVM/MVM may only be operated in combination with the Orbitalum Tools pipe cutter GF 4, GF 6, GF 20, RA 8 or RA 12.
- For GF 4 AVM, GF 6 AVM, GF 20 AVM, RA 8 AVM or RA 12 AVM: only the mains cable of the pipe cutter may be connected to the socket of the AVM.
- The machine may only be used on pipes and containers that are empty, unpressurized, do not have explosive atmospheres and are not contaminated.



Proper use also includes the following:

- observing all safety instructions and warning messages included in these operating instructions
- carrying out all inspection and maintenance work
- sole use in the original condition with original accessories, spare parts and materials
- processing only materials set out in the operating instructions

2.2.2 Improper use

- A use other than that defined under "proper use" or a use that goes beyond this or the specified constraints shall be considered improper use due to the potential risks involved.
- Do not use the machine as a drive for applications other than those listed under proper use (chap. 2.2.1).
- The responsible body shall be solely responsible for damages that arise through improper use and the manufacturer shall assume no liability whatsoever.
- The removal of safety equipment is not permitted.
- Do not misuse the machine.
- The machine is not intended for use by private consumers.
- The technical values defined for normal operation must not be exceeded.



2.2.3 Machine constraints

- Keep your working area clean. Disorder or unlit working areas can lead to accidents.
- The workplace can be in pipe preparation, in plant construction or in the plant itself.
- A radial space requirement/freedom of movement of approx. 2 m around the machine is required for people.

- Work lighting: min. 300 lux.
- Operated by one person.
- Climate conditions: temperature range for machine operation: –15 °C to 40 °C (< 80% rel. humidity).
- Do not use outdoors in fog, rain or during a thunderstorm.

2.2.4 Shutting down the machine

Information on the EMERGENCY STOP or the shutting down function:

For processing with AVM, see chap. 9.1.1, p. 40.

For processing with MVM, see chap. 9.2.1, p. 43.

For manual processing, see chap. 9.3.1, p. 46.

2.3 Environmental protection/disposal

2.3.1 Chips and gear lubricant oil

Dispose of chips and used gear lubricant oil according to the regulations.

2.3.2 Electric tools and accessories

Discarded electric tools and accessories contain large quantities of valuable raw and synthetic materials that can be recycled. Therefore:

- Electrical (electronic) devices that are marked with the symbol to the left may not be disposed of with household waste in accordance with EU regulations.
- By actively using the available return and collection systems, you actively contribute to the reuse, recycling and utilization of electrical (electronic) devices.
- Used electrical (electronic) devices contain parts that must be handled selectively according to EU regulations. Separate collection and selective treatment is the basis for environment-friendly disposal and the protection of human health.
- Appliances and products that you bought from us after August 13, 2005 will be disposed of in accordance with legal standards after they have been supplied to us at no cost.
- We may refuse to accept old appliances that pose a risk to human health or safety due to contamination produced during use.
- The end user is responsible for disposing of used appliances introduced to the market before August 13, 2005. Please contact a disposal center near you for this purpose.
- **Important for Germany:** our products may not be disposed of in municipal disposal sites as they are only used for industrial purposes.

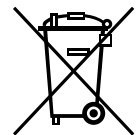

(as per RL 2002/96/EC)

2.3.3 Returning batteries

Some of our units are battery-powered.

- Accumulators and batteries that are marked with one of the symbols to the left may not be disposed of with household garbage according to EU directive 91/157/EEC.
- In batteries containing harmful substances, the chemical sign for the heavy metal contained is indicated below the garbage can: Cd = Cadmium Hg = Mercury Pb = Lead
- **Valid for Germany:** the end user is required to return defective or used batteries to the distributor or to a recycling center established for the purpose.

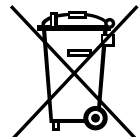

2.4 Basic safety instructions

The pipe cutting and beveling machine (hereinafter referred to as the GF 4, GF 6, GF 20, RA 2, RA 8 or RA 12 (AVM/ MVM)) is a state-of-the-art machine designed for safe use. The risks involved in using the machine are described in the operating instructions below. Using this machine in a way other than that described in these instructions can lead to serious physical injury and material damage.

Therefore:

- Observe warning messages at all times.
- Keep complete documentation close by the machine.
- Observe country-specific regulations, standards and guidelines.
- Always ensure that the machine is in good working order. Observe the maintenance information (see chap. 11.1, p. 52).
- Report any unusual machine behavior to the person responsible immediately.
- Only use the dimensions and materials specified in these instructions. Other materials should be used only after consulting with Orbitalum Tools customer service.
- Repair and maintenance work on the electrical equipment may only be carried out by a qualified electrician.
- At the end of each working cycle, before transportation, changing tools, cleaning and performing any maintenance, adjustment or repair work, switch off the machine, allow it to run to a stop and pull the mains plug.
- Only operate the machine if all the safety equipment such as the restart inhibitor, overload protection and chips guard are in good working order and the machine is firmly positioned.
- Do not carry the machine by the cable and do not use the machine to pull out the plug except in an emergency. Protect the cable from heat, oil and sharp edges (chips).
- During operation, keep hands away from the tools.
- Check that the work piece is correctly clamped.
- Switch on the machine only when the pipe has been clamped.
- When working with the AVM: in case of danger, immediately press the EMERGENCY OFF button.
- When working with the AVM, the AVM stops automatically after each cut. If you are working manually, switch off the machine after each working cycle (ON/OFF switch of the pipe cutter) and allow the machine to run to a stop.
- When working with the AVM, do not stand in the swiveling range (GF 20 AVM: up to 2 m of distance) while the automatic rotary housing is rotating).
- When working with the AVM: the machine may only be operated with the AVM protective bar assembled (for information on the protective bar, see chap. 3.5, p. 16).
- In extreme operating conditions conductive dust can settle inside the machine, so to increase safety, the customer should ensure that an SPE-PRCD or FI protect switch is installed by a qualified electrician between the mains supply and the machine.
- When working with the machine, wear safety shoes in accordance with EN ISO 20345 (at least S1), safety goggles in accordance with DIN EN 166, tight-fitting safety gloves in accordance with DIN EN 388 and ear protection in accordance with DIN EN 352.

NOTE

The recommendations concerning "Personal protective equipment" only apply to the product being described. Other requirements resulting from the ambient conditions on-site or of other products, or from combining with other products, are not taken into account.

These recommendations do not in any way release the responsible body (employer) from its statutory health and safety at work obligations towards its employees.





DANGER

If the mains cable is damaged, live parts may cause death if touched directly.

Fatal electric shock.

- ⊘ Keep the mains cable of the cutter motor **away** from the saw blade or bevel cutter.
- ⊘ **Do not** let the cut-off pipe piece drop in an uncontrolled manner.
- ⊘ **Do not** run the machine unattended.
- ▶ Secure the falling pipe piece.
- ▶ During processing, always keep an eye on the position of the mains cable.
- ▶ Keep the machine clean. Always remove lubricant residues from the machine.
- ▶ The electrical supply cable on the AVM may only be replaced by a qualified electrician.



DANGER

Damaged insulation!

Fatal electric shock.

- ⊘ **Do not** screw any indicators or signs to the drive motor.
- ▶ Use stickers.



DANGER

Damaged plug!

Fatal electric shock.

- ⊘ **Do not** use adapter plugs with ground protected electrical tools.
- ▶ The machine connector plug must fit the socket.



DANGER

Loose/baggy clothing, long hair or jewelry can get caught in rotating machine parts!

Serious injury or death.

- ⊘ During operation, **do not** wear loose/baggy clothing, e.g. neckties.
- ▶ Tie up long hair to prevent it from being caught.



DANGER

Safety components that are contaminated or worn are defective!

The failure of safety components can cause physical injury.

- ⊘ **Do not** misuse the cable, e.g. such as using it to suspend or carry the machine.
- ▶ Replace defective safety components immediately and check them daily to ensure proper operation.
- ▶ Clean and perform maintenance on the machine after each use.
- ▶ Keep cables away from heat, oil, sharp edges and moving equipment parts.
- ▶ Inspect the machine daily for visible signs of damage or defects, and have them repaired by a specialist if necessary.



WARNING

Flying parts/breaking tool!

Diverse physical injuries and material damage.

- ⊘ **Do not** process the pipe while it is loose in the vice.
- ⊘ **Never** use a damaged or deformed saw blade or bevel cutter.
- ⊘ In the event of tool breakage with a new tool, **do not** enter the old cut because the tool can break again (for details of what to do in the event of tool breakage, see chap. 11.4.1, p. 55).
- ▶ Clamp the pipe to be cut into the vice.
- ▶ Immediately replace worn-out tools.
- ▶ Ensure that the cutting tools are correctly fitted.
- ▶ Pipe dimension must be set correctly. During cutting, the saw blade must saw through the entire pipe wall.
- ▶ Avoid breaking tool through low (adequate) feed force, correct dimension (see chap. 8.4, p. 35) and speed (see chap. 8.5, p. 38) settings.
- ▶ Hold on to the motor unit tightly by the handle, and guide it with low (adequate) feed force during the machining process.



WARNING

Falling objects or tilting and bending pipes!

Irreversible crushing.

- ▶ Wear safety shoes (in accordance with EN ISO 20345, at least S1).
- ▶ Place sufficient pipe supports under the pipe.



WARNING

Danger caused by vibration and unergonomic, monotonous work!

Discomfort, tiredness and disruptions to the locomotor system.
Limited ability to react, and cramps.

- ▶ Do relaxation exercises.
- ▶ Ensure activity is varied.
- ▶ Assume an upright and relaxed posture when working.



WARNING

Pressing the ON-OFF switch unintentionally.

Diverse physical injuries and material damage.

- ▶ Before changing tools, cleaning or performing any maintenance, adjustment or repair work, allow the machine to run to a stop and pull the mains plug.



WARNING

Dangerous laser radiation!

The retina of the eyes can be damaged and can thereby impair sight.

- ⊘ **Do not** look at the laser beam or view it using optical instruments.
- ⊘ **Do not** point the laser beam at other people.
- ⊘ **Do not** misuse the line laser and do not remove from the pipe cutter.

Caution – use of controls or adjustments or performance of procedures other than those specified herein may result in hazardous radiation exposure.

2.5 Warning symbols

Observe all of the warnings and safety instructions affixed to the machines.
The following labels also appear on the machine:

Image	Type of machine	Position on machine	Meaning	Code
	GF 4 (AVM/MVM), GF 6 (AVM/MVM), GF 20 AVM, RA 2, RA 8 (AVM/MVM), RA 12 (AVM/MVM)	Motor, side	Instruction: Wear safety goggles in accordance with DIN EN 166, ear protection in accordance with DIN EN 352 and tight-fitting safety gloves in accordance with DIN EN 388. Read the operating instructions.	790 086 200
	GF 4 (AVM/MVM), GF 6 (AVM/MVM), GF 20 AVM, RA 2, RA 8 (AVM/MVM), RA 12 (AVM/MVM)	Chips guard, front	WARNING: Danger of being injured by sharp cutting edges.	790 046 196
	GF 4 (AVM/MVM)	Directly on laser	WARNING: Laser class I.	<u>For Laser 790 142 125:</u> 790 142 288 <u>For Laser 790 142 135:</u> 790 142 298*
	GF 4 (AVM/MVM)	Holder indicut (laser)	WARNING: Dangerous laser radiation.	790 142 289
	GF 6 (AVM/MVM)	Directly on laser	WARNING: Laser class I.	790 142 288
	GF 6 (AVM/MVM)	Slide housing	WARNING: Dangerous laser radiation.	790 142 289

* Warning symbol with Code 790 142 298:



3. PRODUCT DESIGN

NOTE The chips guard is a safety component. The functionality of the chips guard must be checked daily. The chips guard must be able to bend back into the original position (see figures) independently on all of the machines below.

3.1 Pipe Cutting and Beveling Machine GF 4

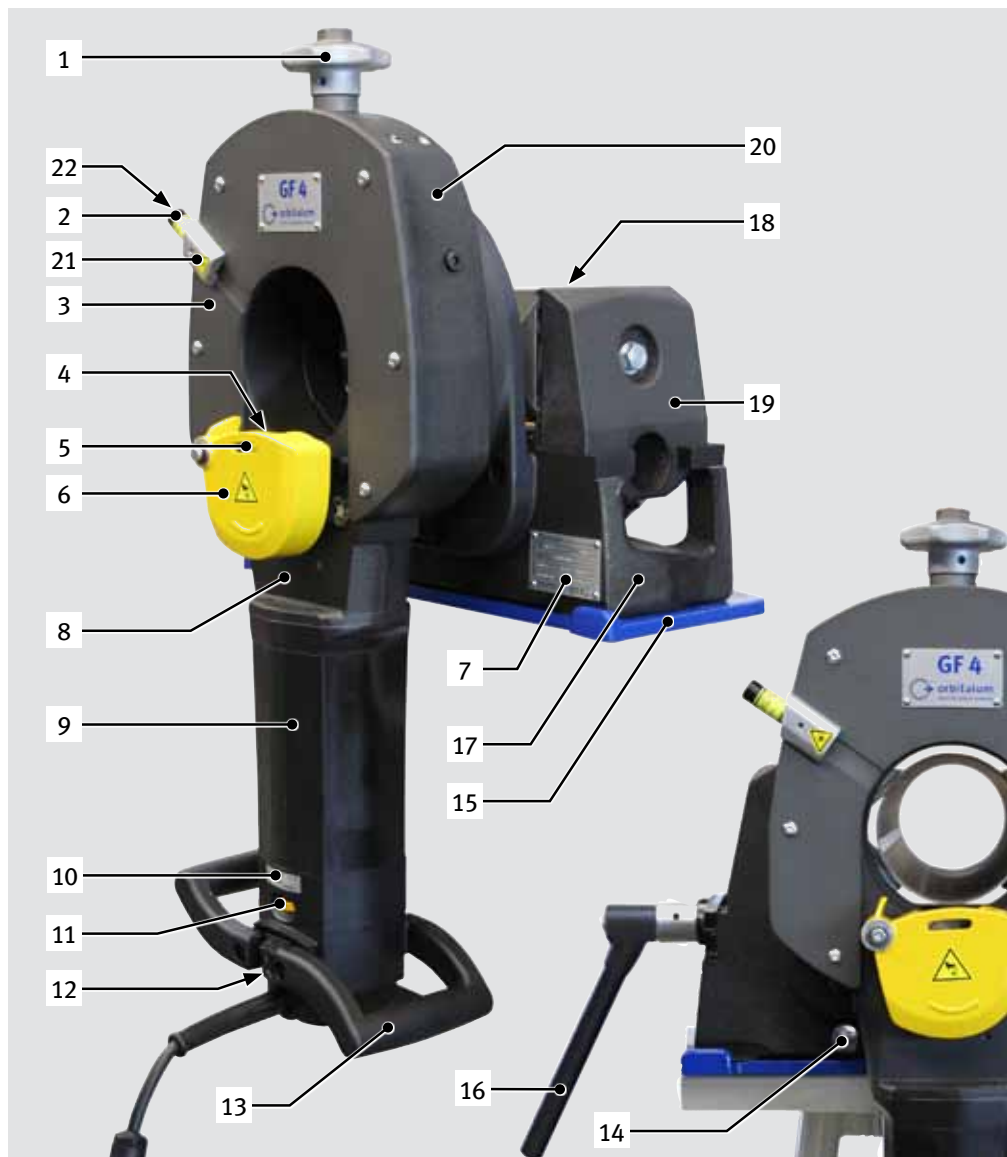

1. Star handle
2. Laser beam pointer
3. Cover plate
4. Saw blade/bevel cutter
5. Opening for meter rule
6. Chips guard
7. Identification plate/
machine number
8. Slide block
9. Motor
10. Rotating-speed
indicator
11. RPM regulator
12. ON-OFF switch
13. Handle
14. Retainer for vice
handle/Holding fixture
for length gauge
15. Mounting plate
16. Multifunctional wrench/
vice handle
17. Vice body
18. Circular clamping jaws
19. Slide jaw
20. Slide housing
21. Holder indicut (laser)
22. ON-OFF switch line
laser

3.2 Pipe Cutting and Beveling Machine GF 6



1. Star handle
2. Cover plate
3. Circular clamping jaws
4. Saw blade/bevel cutter
5. Chips guard
6. Identification plate/
machine number
7. Slide block
8. Motor
9. Rotating-speed
indicator
10. RPM regulator
11. ON-OFF switch
12. Handle
13. Mounting plate
14. Retainer for vice
handle/Holding fixture
for length gauge
15. Multifunctional wrench/
vice handle
16. Vice body
17. Laser beam pointer
18. Slide jaw
19. Slide housing
20. ON-OFF switch line
laser

3.3 Pipe Cutting and Beveling Machine GF 20 AVM

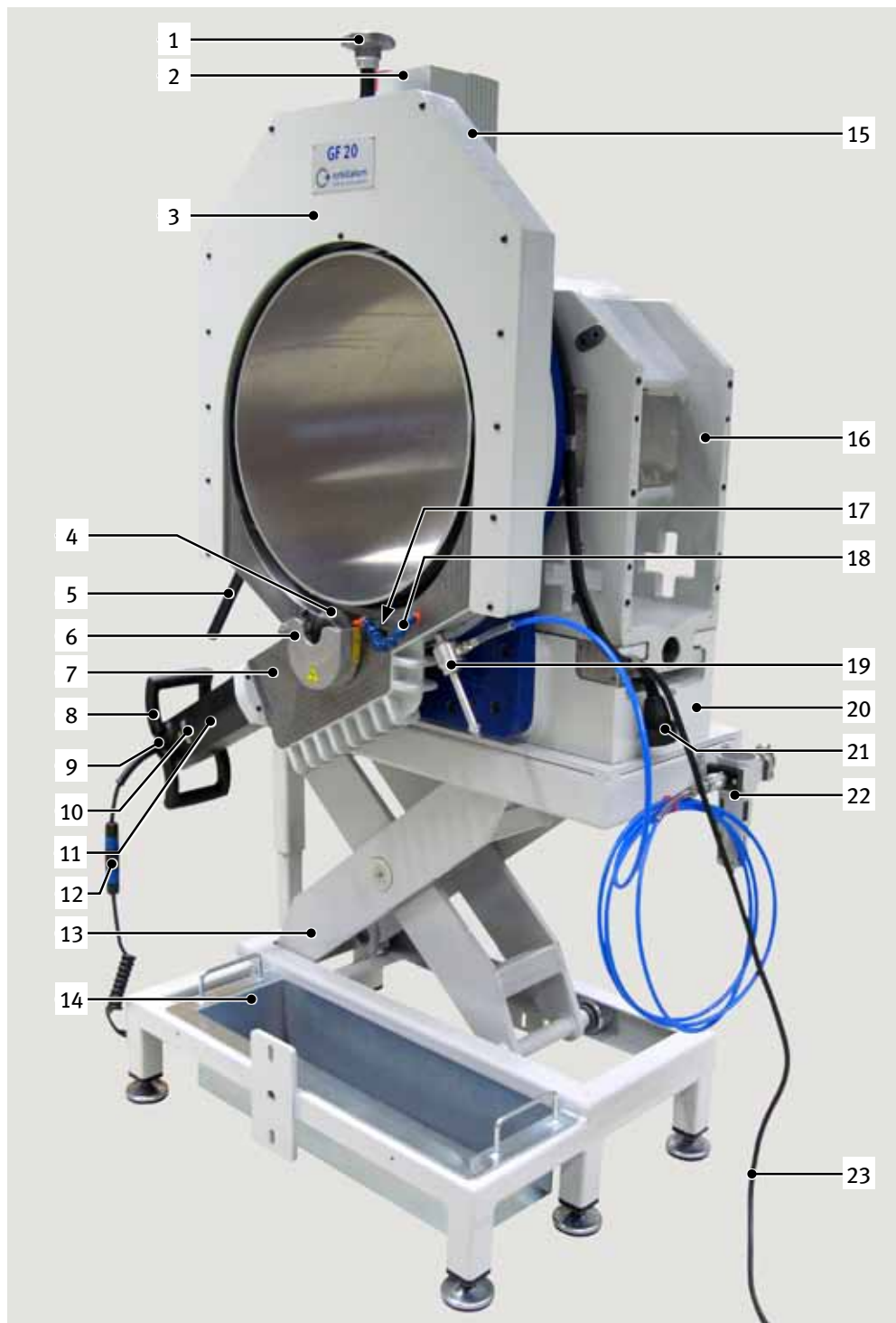

1. Star handle
2. AVM (design, see chap. 3.5, p. 16)
3. Cover plate
4. Saw blade/bevel cutter
5. Multifunctional wrench/vice handle
6. Chips guard
7. Slide block
8. Handle
9. ON-OFF switch
10. RPM regulator/Rotating-speed indicator
11. Motor
12. Plug connection with quick-disconnect coupler
13. Height-adjustable lift-bench
14. Chip collection tray
15. Slide housing
16. Slide jaw
17. Oil level indicator and oil fill plug
18. Flexible hose (Cooling System, see chap. 10, p. 49; not included as standard)
19. Cooling pipe for continuous compressed-air cooling (see chap. 10, p. 49; not included as standard)
20. Vice body
21. AVM outlet
22. Filter (Cooling System, see chap. 10, p. 49; not included as standard)
23. AVM power cable

3.4 Pipe Cutting and Beveling Machines RA 2, RA 8, RA 12



1. Star handle
2. Cover plate
3. Saw blade/bevel cutter
4. Chips guard
5. Identification plate/
machine number
6. Mounting plate
7. Rotating-speed
indicator
8. RPM regulator
9. ON-OFF switch
10. Vice body
11. Slide block
12. Multifunctional wrench/
vice handle
13. Motor
14. Handle

3.5 Automatic Feed Module AVM

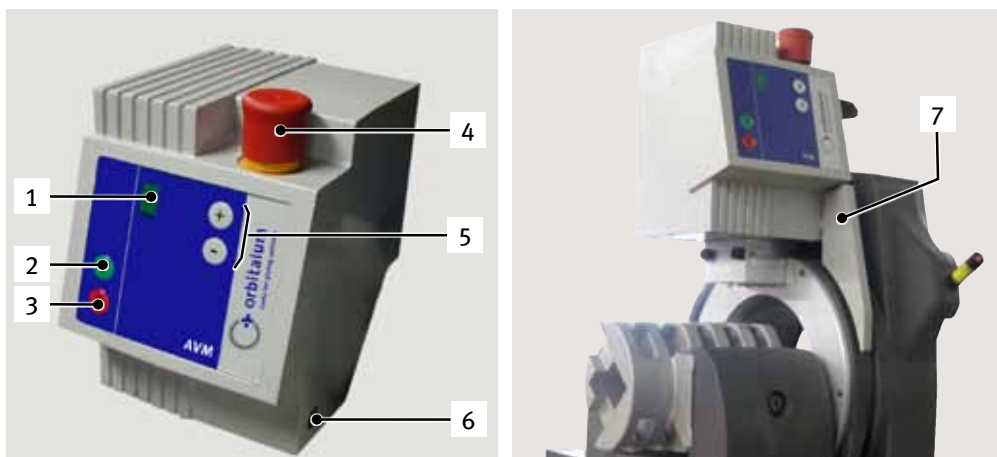

1. Display
2. Start button
3. Stop button
4. EMERGENCY STOP
button
5. Buttons for the feed
force level
6. Light barrier
7. Protective bar

3.5.1 Description of the AVM buttons

Display: If the control unit is connected to the power supply, the display shows the feed force level currently selected. A point is shown in the bottom right of the display to signal that the light barrier recognizes the reflector. The AVM can only be started with reflector recognition. If a fault occurs, this indicator blinks every second and displays **F** and a number from **1** to **6**. For error messages/trouble-shooting, see chap. 11.5, p. 55.

Feed buttons: By pressing these buttons, it is possible to preset the desired feed force in 9 levels. If the device is ready for operation, these buttons may be pressed at any time to set the feed force level or to vary it during processing. If one of the buttons remains pressed by the user, the display runs in the direction selected by the user.

START button: The machining process is initiated by pressing this button when the cutter motor is running.. After start-up, this button serves no further function. It also has no function during a fault or while the software version is being displayed.

STOP button: Pressing this button during the machining process stops the feed and the cutter motor. The cutter motor then has to be returned to the starting position. By pressing the zero button the cutter motor can be turned back more easily. The cutter motor must not be running. As soon as a point lights up in the bottom right of the display the AVM can be restarted.

Calling up the current version of the AVM: The version is displayed when the **+**/**-** buttons are pressed simultaneously. The following sequence then flashes: **S 2 0 0 H 1 2 3**. The first letter, S stands for software, the next three letters stand for the software version, then there is an H for hardware and the three numbers that indicate the hardware version. Then the display returns to the last feed force level that was set.

EMERGENCY STOP button

Only press in an emergency. Pressing the EMERGENCY STOP button interrupts the power supply. Unlock the button to restart.

With error messages the 0 button can be used to switch off the AVM, the error then no longer appears in the display.

3.6 Manual Feed Module MVM

Cannot be used in combination with the RA 2 and the GF 20 AVM.

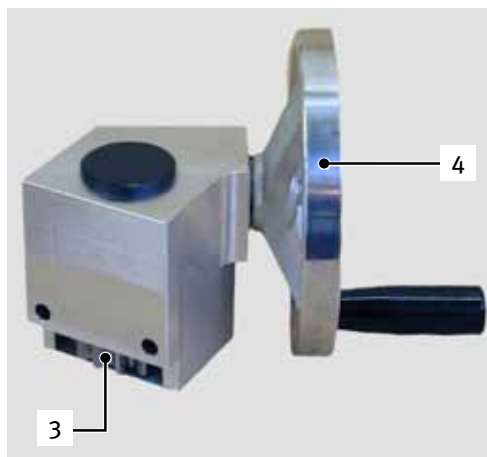
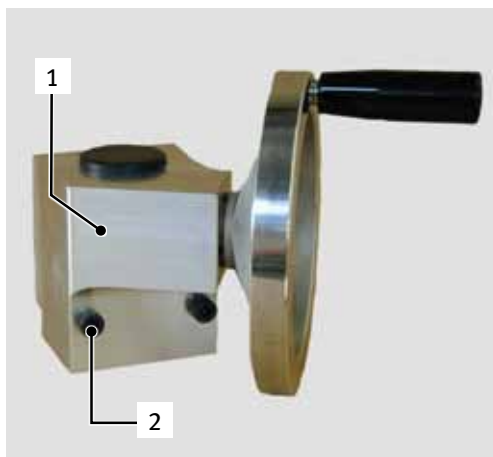

1. Gear
2. Fastening screws
3. Gear drive with free-wheel
4. Hand wheel

3.7 Accessories

Not included as standard.



WARNING

Danger presented by using poor-quality accessories and tools not approved by Orbitalum Tools!
Diverse physical injuries and material damage.

► Use only original tools, spare parts, materials, and accessories from Orbitalum Tools.

3.7.1 Saw blades and bevel cutters

All saw blades and bevel cutters are specially developed for Orbitalum Tools pipe cutters to endure maximum strain and have a maximum tool life.

4 different saw blades and bevel cutters are available for different uses:



Workable pipe materials	Al	Mild steel, Cu, CuNi, CuZn, CuSn	INOX, V2A, V4A, 304, 316 (L)	Ti, Duplex, Inconel
Economy range for low and non-alloy steels and cast iron pipes	*	*		
Performance range for high-alloy steels (stainless steel)		*	*	
High-Performance range for high-performance materials and high-alloy steels		*	*	*
Premium range especially made for stainless steel applications with extra long durability			*	

Please see our latest product catalog for a large selection of saw blades and bevel cutters.

3.7.2 Aluminum clamping shells for GF 6, RA 8, RA 12

For deformation-free clamping of thin-walled pipes. The aluminum clamping shells are produced for specific customers. When ordering, please indicate the outside diameter and/or inside diameter and the wall thickness of the pipe to be processed.

4 cylinder screws and 1 set of clamping shells are included.

When ordering clamping shells for RA 8, you also receive 1 drilling jig for assembling clamping shells and 2 cylinder screws for the drilling jig. Other dimensions are available.



Please see our latest product catalog for a large selection of aluminum clamping shells.

3.7.3 Aluminum clamping shells for GF 4 and RA 41 Plus

For deformation-free clamping of thin-walled pipes.

Other clamping shells are available for various outer diameters.

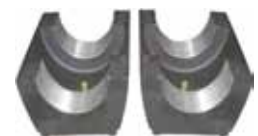

Article	Pipe OD [mm]	Pipe OD [inch]	Code
Aluminum clamping shells for GF 4 and RA 41 Plus	25.40	1.000	790 046 316
Aluminum clamping shells for GF 4 and RA 41 Plus	38.10	1.500	790 046 331
Aluminum clamping shells for GF 4 and RA 41 Plus	50.80	2.000	790 046 345
Aluminum clamping shells for GF 4 and RA 41 Plus	76.10	2.996	790 046 358
Aluminum clamping shells for GF 4 and RA 41 Plus	88.90	3.500	790 046 363
Aluminum clamping shells for GF 4 and RA 41 Plus	108.00	4.252	790 046 367
Aluminum clamping shells for GF 4 and RA 41 Plus	114.30	4.500	790 046 368

3.7.4 Special high quality stainless steel clamping jaws

For RA 2, GF 4, RA 4 and RA 41 Plus. In pairs. Can be retrofitted.
While stock last.



Article	Code
Special stainless steel clamping jaws for RA 2	790 041 323
Special stainless steel clamping jaws for GF 4, RA 4 and RA 41 Plus	790 042 201

3.7.5 Set of stainless steel caps

For GF 4 and GF 6 (AVM/MVM). Prevents contact corrosion between tube and clamping parts.
The stainless steel caps are supplied as standard with the GF 4 and GF 6 (AVM/MVM).



Article	Code
Set of stainless steel caps for GF 4, right + left	790 142 241
Set of stainless steel caps for GF 6, right + left	790 143 200

3.7.6 Quick-mounting plate with screw clamps

With integrated screw clamps for quick mounting of the machine on workbenches.
Ideal if changing location often.



Article	Code
Quick-mounting plate for GFX 3.0, RA 2, RA 21 S	790 041 027
Quick-mounting plate for GF 4, RA 4, GF 6, RA 8, RA 41 Plus	790 042 027
Quick-mounting plate for PS 4.5 and PS 6.6	790 048 334

3.7.7 Special gear oil

For all GF and RA machines.



Article	Code
Special gear oil, bottle, 250 ml	790 041 030

3.7.8 Saw blade lubricant GF TOP

Synthetic high-performance lubricant for cutting and beveling machines. Increases the tool life of the saw blade. Compliant with the NSF H2 food approval. The screwable brush guarantees an easy and uniform application of lubricant on the saw blade.



Article	Code
Saw blade lubricant GF TOP	790 060 228

3.7.9 Saw blade lubricant GF LUB

For cutting and beveling. Increases the tool life of the saw blade. The ecological lubricant is the environmentally-friendly successor to ROCOL; with a new name and improved quality. GF LUB complies with the latest environmental guidelines and ecological standards. The chlorine-free GF LUB can be ordered using the same article number as the previous lubricant, ROCOL.



Article	Code
Saw blade lubricant GF LUB, Tube, 160 ml	790 041 016

3.7.10 Continuous cooling system

For GF 20 AVM. For GF 4, GF 6, RA 8 and RA 12 on request.
To increase the service life of the tool and for improved surface finish to the pipe. Infinitely variable. The system is cooled with compressed air fed through a vortex tube. The cooling air rate can be configured to the optimum level for your application. Also suitable for cutting plastic pipes. Cooling without coolants. The tool is constantly cooled during the cutting process with cold air (to -37°C).



Consumption [slpm]	Temperature decrease [°C]*	[kcal/h]
351	46 (with 5.5 bar compressed air)	192
425	47 (with 6.9 bar compressed air)	227

* The temperature of the air current can also be reduced by 11 °C. Lower air current temperatures can also be achieved by increasing the flow of hot air through adjusting the pin valve. The pin valve is located in the hot air outlet. Vortex tubes produce a lower air current at lower temperatures, and at lower BTUH or kcal/h performance.

Article	Version	Code
Continuous cooling system	Compressed air (5.5 - 8.0 bar required)	790 050 773

3.7.11 Aluminum clamping shells for GF 20 AVM

For GF 20 AVM Ideal for clamping thin-walled pipes.
When ordering, please indicate the outside diameter of the tube to be worked on.
Included in the scope of delivery:

- 4 clamping shells
- 8 cylinder screws
- 8 cylinder pins



Article	Code
Aluminum clamping shells for GF 20 AVM	On request

3.7.12 Cutting lubrication KSS-TOP

The water soluble, fully synthetic cooling fluid extends the tool life of the tool bits.
 Contains no hazardous substances (no labeling requirements according to GefStoffV).
 Meets drinking water requirements in accordance with DVGW work sheet W521.
 Good anti-corrosion properties.



Article	Code
Cutting lubrication KSS-TOP, 500 ml pump sprayer	790 060 226
Cutting lubrication KSS-TOP, 10 l refill canister	790 060 227

3.7.13 Warning symbols

Overview of warning symbols with order numbers, see chap. 2.5, p. 12.

4. FEATURES AND SCOPE OF APPLICATION

4.1 Features

The pipe cutters are distinguished by the following characteristics:

- Enhanced safety due to stationary pipe – rotating tool.
- A restart inhibit function prevents the machine from starting in an uncontrolled way after it has been re-connected to the electric mains or after the voltage supply has been re-established following a power failure.
- Self-centering clamping system.
- Low-maintenance gear with oil lubrication.
- Saw motor with RPM control and ergonomically optimized motor for more secure operator position.
- Burr-free cutting surface and deformation-free pipe cross-section.
- Cold machining process.
- Quick cutting process.
- Production of standardized welding bevels.
- Cutting of pipe elbows.
- Quick tool change.
- Plug connection with quick-disconnect coupler: for easy and comfortable replacement of the power cable. Also prevents cables from twisting.
- Working without getting tired when cutting and beveling pipes with larger pipe dimensions and thicker walls.
- Laser beam for optically marking the cutting area (for GF 4 and GF 6 AVM/MVM only).
- Locking mechanism of the slide housing prevents unauthorized usage and theft (for GF 4 and GF AVM/MVM only).

Additional properties of the GF 4 AVM, GF 6 AVM, GF 20 AVM, RA 8 AVM or RA 12 AVM:

- The intelligent control system of the AVM monitors the feed force continuously depending on the torque and the parameter settings.
- The operator position guarantees the best possible protection against hot chips flying around.
- Advancing the pipe cutter in a usual way by operating the handle of the pipe cutter motor is always possible (e.g. when cutting thin-walled pipes).

4.2 Additional properties of the GF 4 and GF 6 (AVM/MVM)

Protection against corrosion



Anthracite-colored coated components for improved sliding properties and protection against corrosion.

Multifunctional wrench

Detachable. It is possible to make 6 different adjustments on the machine using this multifunctional wrench:



Dimension adjustment



Vice handle



Fixture for clamping jaws (GF 4 (AVM/MVM) only)



Fixture for saw blade/bevel cutter



Fixture of the saw for quick-mounting plate

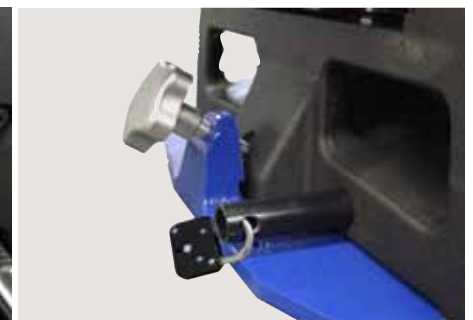

Locking mechanism of the slide housing prevents unauthorized usage and theft

Line laser to display cut-off point

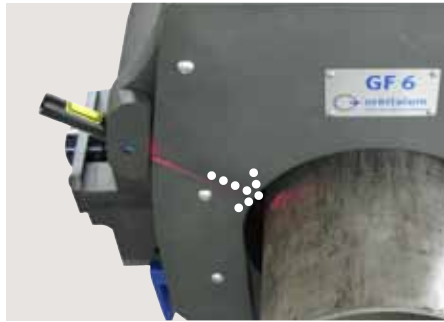

To mark the cut-off point on the pipe. Ideal for checking whether the pipe is adjusted to the desired cut-off point. A red line that marks the cut-off point appears on the clamped pipe once the red button on the line laser has been pressed. If necessary, the pipe position can be corrected until the desired cut-off point is marked.

Reversible clamping jaws



The reversible clamping jaws are a standard feature of the GF 4 and GF 6 (AVM/MVM). Turning the clamping jaws allows the following pipe diameters to be processed:

Machine	Pipe OD [mm]	Pipe OD [inch]
GF 4 (AVM/MVM)	12 - 56 / 20 - 120	0.472 - 2.205 / 0.787 - 4.724
GF 6 (AVM/MVM)	21.3 - 106 / 106 - 168.3	0.839 - 4.173 / 4.173 - 6.626

Clamping jaw assembly, see chap. 8.2, p. 32.

Plug connection with quick-disconnect coupler



For easy and comfortable replacement of power cables. Also prevents cables from twisting.

Optimized chip guard



Optimized chip guard protects against flying chips and comes with a meter rule slot for measuring the pipe length (GF 4 only).

Stainless steel clamping attachment



Ideal for processing stainless steel pipes. For protection against contact corrosion.

4.3 Scope of application

4.3.1 Working range

Type of machine		GF 4 (AVM/MVM)	GF 6 (AVM/MVM)	GF 20 AVM	RA 2	RA 8 (AVM/MVM)	RA 12 (AVM/MVM)
Pipe OD/pipe elbow OD*	[mm]	12 - 120	21.3 - 168.3	283 - 508	12 - 63	114 - 230	154 - 325
	[inch]	0.472 - 4.724	0.839 - 6.626	11.14 - 20	0.472 - 2.480	4.488 - 9.055	6.063 - 12.795
Wall thickness (depends on material)**	[mm]	1 - 9	1.5 - 15	15.0	1.5 - 5.5	2 - 10	2 - 10
	[inch]	0.039 - 0.354	0.059 - 0.591	0.590	0.059 - 0.217	0.079 - 0.394	0.079 - 0.394
Pipe ID min. (Saw blade Ø 63 mm/2.480")	[mm]	21	30	–	7	137	190
	[inch]	0.827	1.181	–	0.276	5.394	7.480
Pipe ID min. (Saw blade Ø 68 mm/2.677")	[mm]	16	25	–	2	132	185
	[inch]	0.630	0.984	–	0.079	5.197	7.283
Pipe ID min. (Saw blade Ø 80 mm/3.150")	[mm]	4	13	295***	–	120	173
	[inch]	0.157	0.512	11.600***	–	4.724	6.811
Pipe ID min. (Saw blade Ø 100 mm/3.937")	[mm]	–	0	275	–	100	153
	[inch]	–	0	10.800	–	3.937	6.024
Pipe ID min. (Saw blade Ø 110 mm/4.331")	[mm]	–	0	265	–	–	–
	[inch]	–	0	10.433	–	–	–

* The pipe elbows can only be separated with the GF 4 and GF 6 (AVM/MVM).

** With automatic cutting process. Greater wall thicknesses possible through manual feed or through another cut-off point (depending on the diameter of the saw blade). Special clamping shells (accessory) may be necessary for thin pipe wall thicknesses.

*** max. wall thickness: 7.5 mm (0.296 inch).

4.3.2 Materials

- High-quality steel (any Cr and Mo content)
- High-quality stainless steel (any Cr and Mo content)
- High-quality steel (Cr < 12% and Mo < 2.5%; Cr < 20% and Mo = 0%): case hardened steels, high-speed steels, tempering steels, bearing steels, tool steels
- Black and galvanized steel pipe
- General structural steel
- Annealed cast iron pipe (GGG)
- Aluminum
- Brass
- Copper
- Plastics (PE, PP, PVDE, PVC)

5. TECHNICAL DATA

5.1 Pipe Cutting and Beveling Machines

Type of machine		GF 4 (AVM/MVM)	GF 6 (AVM/MVM)	GF 20 AVM	RA 2	RA 8 (AVM/MVM)	RA 12 (AVM/MVM)
Dimensions (lxwxh)	[mm]	680 x 325 x 480	920 x 352.7 x 574	–	620 x 350 x 420	778 x 485 x 430	940 x 592 x 374
	[inch]	26.8 x 12.8 x 18.9	36.2 x 13.9 x 22.6	–	24.4 x 13.8 x 16.5	30.6 x 19.1 x 16.9	37.0 x 23.3 x 14.7
Dimensions (lxwxh) with AVM	[mm]	810 x 325 x 480	972 x 352.7 x 574	***	–	918 x 485 x 430	1.070 x 592 x 374
	[inch]	31.9 x 12.8 x 18.9	38.3 x 13.9 x 22.6	***	–	36.1 x 19.1 x 16.9	42.1 x 23.3 x 14.7
Dimensions (lxwxh) with MVM	[mm]	780 x 325 x 480	920 x 352.7 x 574	–	–	788 x 485 x 430	1.090 x 592 x 374
	[inch]	30.7 x 12.8 x 18.9	36.2 x 13.9 x 22.6	–	–	31.0 x 19.1 x 16.9	42.9 x 23.3 x 14.7
Machine weight approx.*	[kg]	55.0	92.7	–	45.0	102.5	138.6
	[lbs]	121.2	204.4	–	99.2	225.9	305.6
Machine weight approx.* with AVM	[kg]	64.5	101.7	482.0	–	110.0	146.1
	[lbs]	142.2	224.2	1.062.6	–	242.5	322.1
Machine weight approx.* with MVM	[kg]	60.0	97.8	–	–	104.6	140.7
	[lbs]	132.2	215.6	–	–	230.6	310.2
GF 20 AVM: max. load capacity of lifting bench approx.	[kg]	–	–	1.200	–	–	–
	[lbs]	–	–	2.645.5	–	–	–
Versions, 1 phase AC	[V,Hz]	230 V, 50/60 Hz	230 V, 50/60 Hz	230 V, 50/60 Hz	230 V, 50/60 Hz	230 V, 50/60 Hz	230 V, 50/60 Hz
	[V,Hz]	120 V, 50/60 Hz	120 V, 50/60 Hz	120 V, 50/60 Hz	120 V, 50/60 Hz	120 V, 50/60 Hz	120 V, 50/60 Hz
Power without AVM	[kW]	1.8	1.8	–	1.8	1.8	1.8
	[HP]	2.41	2.41	–	2.41	2.41	2.41
Power with AVM	[kW]	1.9	1.9	1.9	–	1.9	1.9
	[HP]	2.54	2.54	2.54	–	2.54	2.54
Power AVM	[kW]	0.05	0.05	0.05	–	0.05	0.05
	[HP]	0.07	0.07	0.07	–	0.07	0.07
Protection class	Double-insulated according to Class II, DIN EN 60745-1						
Protection class with AVM	Double-insulated according to Class I, EN 60204-1						
Protection class with MVM	Double-insulated according to Class II, DIN EN 60745-1						
Tool speed	[rpm]	65 - 215	65 - 215	50 - 163	65 - 215	65 - 215	65 - 215
Slide housing speed with AVM	[rpm]	0.1 - 3.9	0.3 - 3.5	0.1 - 1.1	–	0.1 - 2.3	0.1 - 1.8
Slide housing torque max. with AVM	[Nm]	101	353	350	–	165	210
Sound pressure level at the workplace approx.**	[dB (A)]	79	79	79	79	79	79
Vibration level	[m/s ²]	< 2.5 in accordance with DIN EN 28662, Part 1					
Mains fuse by customer	[A]	16	16	16	16	16	16

* Weight without packaging and accessories. Weight GF 20 AVM, lifting bench included.

** The sound pressure level was measured under normal operating conditions in accordance with EN 23741.

*** Dimensions of GF 20 AVM incl. lifting bench (h x w x d): approx. 145 - 171 x 94 x 63 cm (57.1 - 67.3 x 37 x 24.8 inch); Dimensions lifting table min.-max. (h x w x t): approx. 44.5 - 70.5 x 94 x 63 cm (17.5 - 27.8 x 37 x 24.8 inch)

5.2 Line laser

Component for the GF 4 and GF 6 (AVM/MVM) only.

Dimensions (lxb)	[mm]	68 x 15
	[inch]	2.7 x 0.59
Weight	[g]	30
	[lbs]	0.012
Power, Total Emitted	[mW]	5
	[HP]	5x10 ⁻⁶
Power for Classification	[μW]	< 390
Beam range	[m]	1
	[inch]	3.937
Wave length	[Nm]	650
Operating voltage	[V DC]	2.8 to 4.5
Operating current	[mA]	20
Operating temperature	[°C]	-10 to 40
Storage temperature	[°C]	-40 to 80
Laser class	Class 1	
Battery type	2 x LR44 / AG13	

6. INITIAL OPERATION

6.1 Checking the parts of delivery

- Check delivery for completeness and damage caused by transport.
- Report any missing parts or damage caused by transport to your supplier immediately.

6.2 Included with the machine

- 1 Pipe Cutting and Beveling Machine GF 4, GF 6, GF 20, RA 2, RA 8 or RA 12 (AVM/MVM)*
- 1 Transport case
- 1 Lifting bench (Code 790 050 051, for GF 20 AVM only)
- 1 Set of stainless steel caps (for GF 4 and GF 6 (AVM/MVM only)
- 1 Saw blade (GF 4: Code 790 042 064, GF 6: 790 043 018, GF 20: Code 790 047 026, RA 2: 790 041 035, RA 8: 790 043 018, RA 12: 790 043 018)
- 1 Mounting plate (not for GF 20 AVM)
- 1 Tool key set
- 1 Tube of saw blade lubricant GF TOP (Code 790 060 228, not for GF 20 AVM)
- 1 Bottle of special gear oil (Code 790 041 030)
- 1 Pump sprayer cutting lubrication KSS-TOP (Code 790 060 226, for GF 20 AVM only)
- 1 Set instruction manual and spare parts list

* *The automatic and manual feed module AVM/MVM is already fitted to the pipe cutter upon delivery.*

7. STORAGE AND TRANSPORT

7.1 Storage



ATTENTION

Incorrect machine storage!

Diverse physical injuries and material damage.

- ▶ Store the machine in its original crate in a dry environment.

NOTE

For GF 4, GF 6, GF 20, RA 8 or RA 12 with AVM/MVM: The automatic and manual feed module AVM/MVM is already fitted to the pipe cutter upon delivery.

7.1.1 Position of the cutter in the transport case



GF 4 (AVM/MVM)

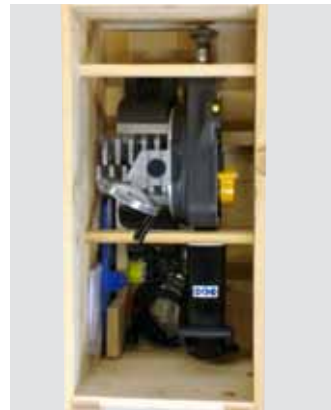

GF 6 (AVM/MVM)



GF 20 AVM



RA 2, 8, 12 (AVM/MVM)

NOTE

The accessories in the GF 6 (AVM/MVM) must be taken out of the transportation case before the frame is removed.

7.2 Transport



DANGER

Fatal electric shock!

- ▶ Before transportation or changing the workplace, allow the machine to run to a stop and pull the mains plug.



WARNING

During transportation, the ON/OFF switch may unintentionally be activated causing the machine to start up!

Diverse physical injuries and material damage.

- ▶ Before transportation or changing the workplace, allow the machine to run to a stop and pull the mains plug.



WARNING

Heavy weight when transporting the pipe cutters!

Danger of being injured through overstraining.

- ▶ Transport pipe cutters over long stretches with corresponding lifting aids.

7.2.1 Transporting the GF 4, GF 6, RA 2, RA 8 (AVM/MVM)

1. Loosen the hexagon bolt (1) on the quick-mounting plate.
2. Guide suitable transport straps through the pipe cutter slide housing.
3. Carefully lift the cutter at the straps and insert in the assembled quick-mounting plate on the side.
4. Bolt the pipe cutter securely in place on the mounting plate with the hexagon bolt (1).



7.2.2 Transporting the GF 20 AVM

NOTE The GF 20 AVM pipe cutter comes with the height-adjustable lifting bench already assembled. The product is delivered in a wooden crate (see chap. 7.1.1, p. 29).

IMPORTANT The bases of the lifting bench for the GF 20 AVM must be adjusted to the flooring conditions so that all the bases are in contact with the floor.

IMPORTANT Moving masses must have a minimum clearance of 1 m from the machine.

1. Use a screwdriver to remove the front and top panels of the wooden crate.
2. Use a screwdriver to remove the wooden retaining mounts in the crate.
3. Use a hand forklift to lift the pipe cutter out of the crate and move it to the desired location.

7.2.3 Transporting the RA 12

1. Suspend the crane hooks in the catch (2), lift and insert in the assembled quick-mounting plate on the side.
2. Bolt the pipe cutter securely in place on the mounting plate with the hexagon bolt (1).



8. SETUP AND ASSEMBLY

NOTE The steps described in chap. 8 are the same for all GF and RA versions.

8.1 Mounting the pipe cutter on the workbench

Not required for GF 20 AVM. This is already supplied on a height-adjustable lifting table (see chap. 3.3, p. 15).

Mount the pipe cutter together with the vice, either:

- on the quick-mounting plate (see chap. 8.1.1 for assembly), or
- on the quick-mounting plate with screw clamps (plate is clamped directly to the workbench without pre-drilling).

8.1.1 Mounting the quick-mounting plate on the workbench

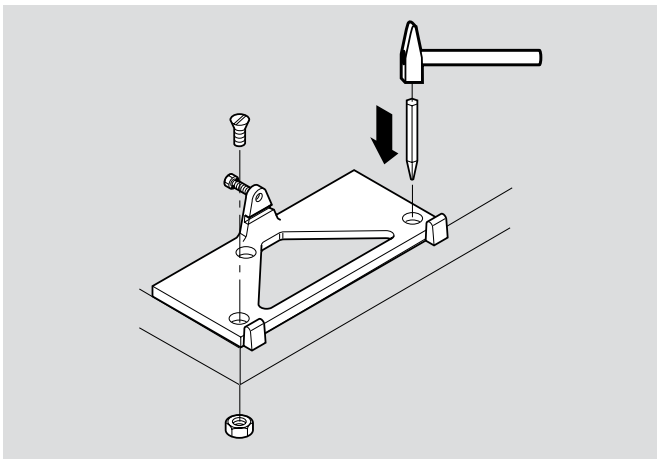

1. Mark and punch the bolt holes on the workbench. Use the quick-mounting plate as a template.
2. Drill \varnothing 13 mm holes.
3. Fasten the quick-mounting plate with screws.

8.1.2 Mounting the pipe cutter on the quick-mounting plate

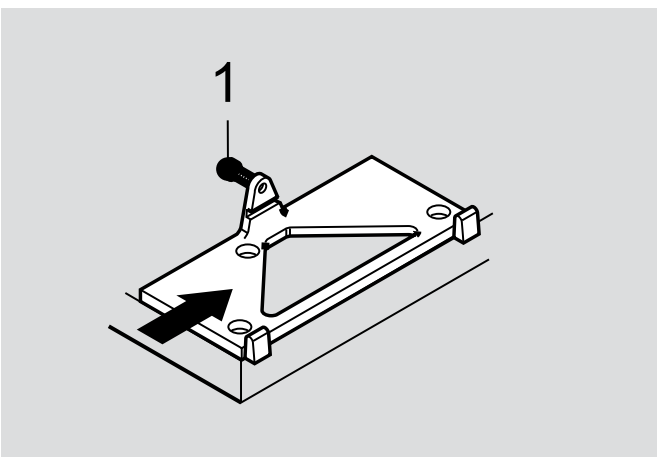

1. Only insert the pipe cutter in the assembled quick-mounting plate on the side with the help of a crane or a similar lifting tool.
2. Bolt the pipe cutter securely in place with the hexagon bolt.

8.1.3 Pipe feeder (base and extension unit, mobile workstation)

When using the Orbitalum Tools pipe feeder base unit, the pipe cutter is directly fitted to the mounting plate of the base unit without special accessories (special accessories, code no. 790 068 051).

NOTE We recommend supporting pipes longer than 1 m with one of the pipe feeders listed below (all special accessories).

IMPORTANT When working with the GF 20 AVM, support pipes with a length of more than 0.2 m using the optional unit listed below (Code 790 050 061).



Pipe feeder base unit (Code 790 068 051)



Pipe feeder extension unit (Code 790 068 061)



Extension unit for GF 20 AVM (Code 790 050 061)



Mobile Workstation (Code 790 068 071)

8.2 GF 4 and GF 6: fitting the clamping jaws

Clamping jaw characteristics, see chap. 4.2, p. 23.

8.2.1 Fitting the clamping jaws

1. Loosen the hexagon bolt (1) on the side of the vice of the GF 4 using a multifunctional wrench (2) and on the GF 6 with an SW8 socket head key.
2. Insert the clamping jaws.
3. Tighten hexagon bolts (1).

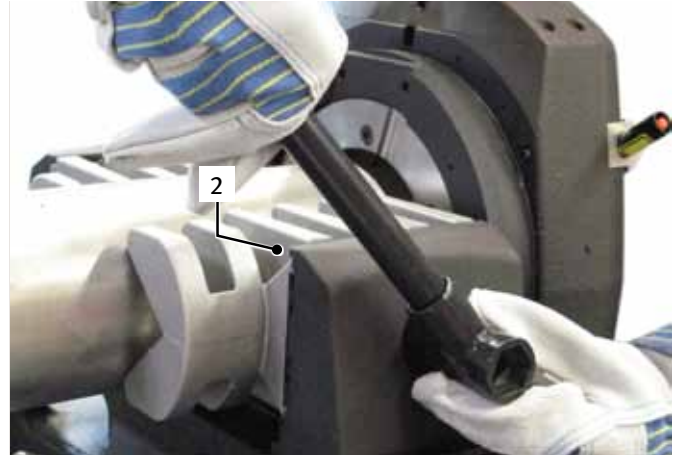

8.3 Fitting the saw blade, bevel cutter, additional cutters



WARNING

When switching the motor on, the pipe cutter may revolve around the pipe automatically.
Diverse physical injuries and material damage.

- ⊘ In their home position, the saw blade or bevel cutter must **not** touch the pipe.
- ▶ Make sure that the slide housing is in the home position when the cutting process starts.
- ▶ Clamp the pipe to be cut into the vice.
- ▶ Pull off the hand wheel from the spindle before the slide housing starts rotating.
- ▶ Before switching the motor on, make sure that the gap between the saw blade/bevel cutter and the pipe is sufficient, and that the pipe is securely clamped in the vice.
- ▶ Place sufficient pipe supports under the pipe.

ATTENTION

Damage to material!

- ⊘ When using an additional cutter, only use the special Orbitalum Tools clamping plate (code 790 046 188); **not** the clamping plate supplied as standard with the cutters.
- ⊘ **Never** use a damaged or deformed saw blade or bevel cutter.
- ▶ The saw blade or bevel cutter must be free from chips and dirt.
- ▶ Only use original tools by Orbitalum Tools.
- ▶ Mount the saw blade/bevel cutter or additional cutter with the inscription facing you. The teeth will then be pointing in the correct direction.

ATTENTION

Flying parts/breaking tool!

Diverse physical injuries and material damage.

- ⊘ **Do not** process the pipe while it is loose in the vice.
- ⊘ **Never** use a damaged or deformed saw blade or bevel cutter.
- ▶ Clamp the pipe to be cut into the vice.
- ▶ Immediately replace worn-out tools.
- ▶ Ensure that the cutting tools are correctly fitted.
- ▶ Pipe dimension must be set correctly. During cutting, the saw blade must saw through the entire pipe wall.
- ▶ Avoid breaking tool through low (adequate) feed force, correct dimension (see chap. 8.4, p. 35) and speed (see chap. 8.5, p. 38) settings.
- ▶ Hold on to the motor unit tightly by the handle, and guide it with low (adequate) feed force during the machining process.

IMPORTANT Before fitting the saw blade or bevel cutter: Move the slide (9) all the way down using the hand wheel (8).

8.3.1 Inserting the saw blade or bevel cutter

1. Turn the chip guard (1) down for approx. 90°.
2. Loosen the hexagon nut (4). Remove the clamping plate (3) and the saw blade (2).
3. Clean the saw blade shaft (6) and vicinity with a brush.
4. Fit the saw blade (2) or bevel cutter and the clamping plate (3).
5. Tighten the hexagon nut (4) a fraction.
6. Move the saw chip guard (1) back to its original position.

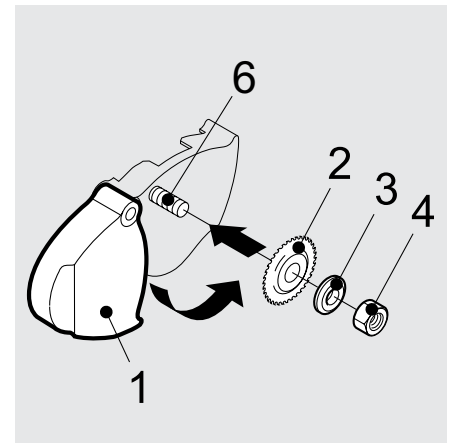
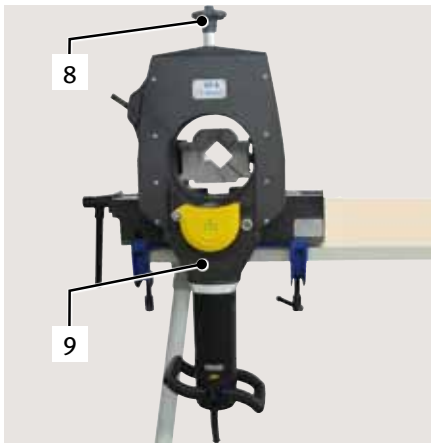

NOTE Make sure that the felt ring (7) is on the locking sleeve.

8.3.2 Inserting the saw blade/bevel cutter combination

1. Turn the chip guard (1) down for approx. 90°.
2. Loosen the hexagon nut (5). Remove the clamping plate and the saw blade.
3. Clean the saw blade shaft (6) and vicinity with a brush.
4. Fit the additional cutter (2), the saw blade (3) and the special clamping plate (4).
5. Tighten the hexagon nut (5) a fraction.
6. Move the saw chip guard (1) back to its original position.

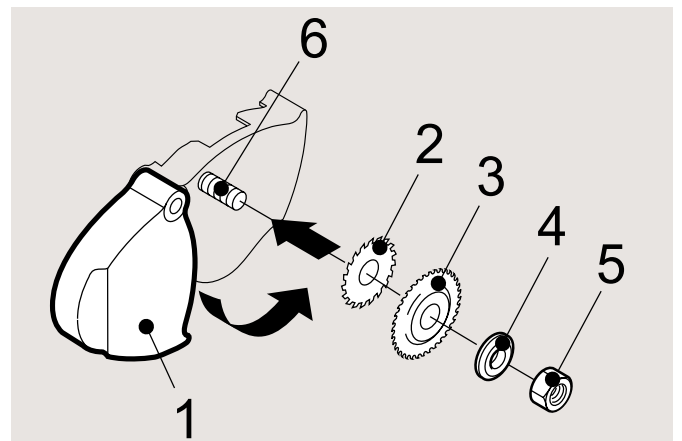
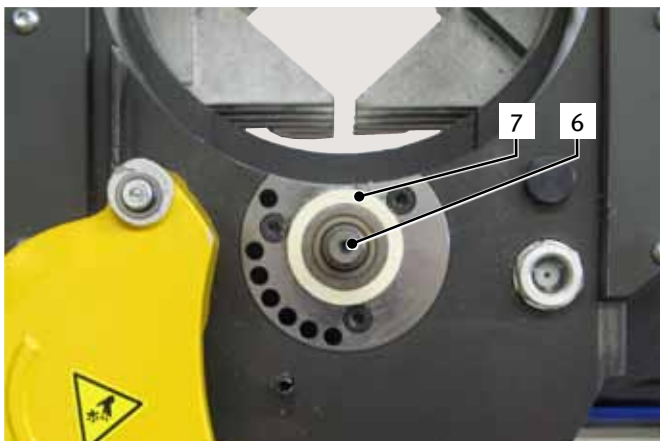

NOTE Make sure that the felt ring (7) is on the locking sleeve.

8.4 Adjusting the pipe dimension

NOTE We recommend supporting pipes longer than 1 m with a pipe feeder or extension unit (see chap. 8.1.3, p. 32).

8.4.1 Saw blade without additional cutter

1. Turn the slide with saw blade all the way down using the hand wheel (1).
2. Insert the pipe so that it almost reaches the saw blade (3) and tighten using the multifunctional wrench (4).

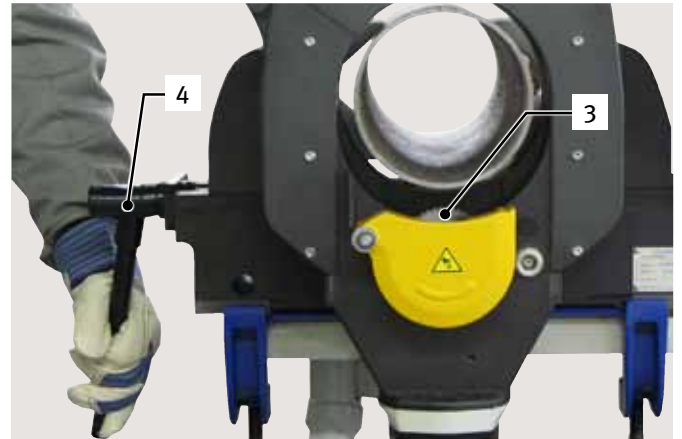

3. Use the handle to turn the motor upwards for about 30° (clockwise) until the saw blade is in cutting position.
4. Turn the hand wheel (1) until the teeth of the saw blade (3) protrude about 1 to 2 mm (0.039 - 0.079 inch) inside the pipe (2).
5. If desired, perform a test cut (cutting the pipe, see chap. 9.1.3, p. 41 for machines with AVM, chap. 9.2.2, p. 43 for machines with MVM and chap. 9.3.2, p. 46 for working without AVM/MVM), check the cut result and readjust the hand wheel (1) if necessary.
6. Turn the motor back to its home position.

When working with the AVM: Hold down the STOP button (6), and pivot the motor back into the normal position.

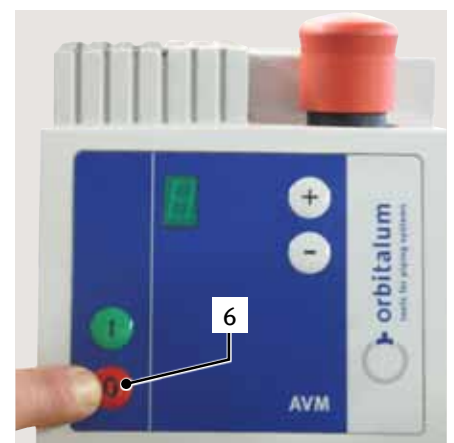
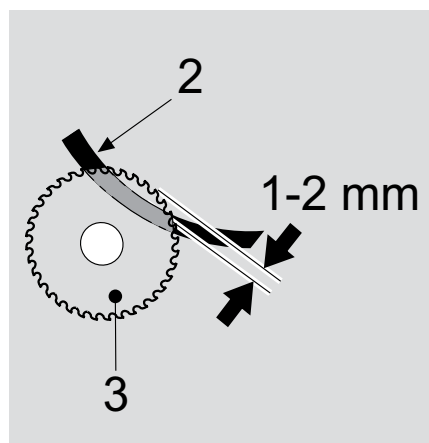
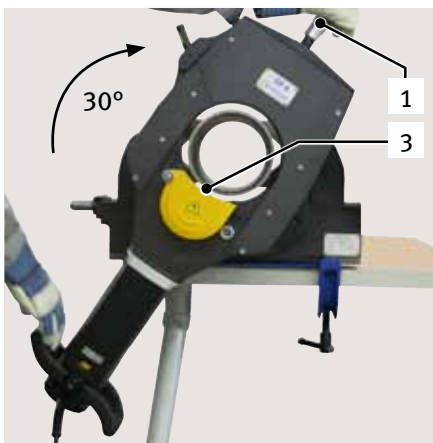

NOTE Scale of the hand wheel: a readjustment by one graduation mark results in a radial feed or bevel alteration of 0.1 mm (0.004 inch), for the GF 6 and GF 20 AVM of 0.2 mm (0.008 inch).

8.4.2 Saw blade with additional cutter

1. Turn the slide with the saw blade and additional cutter (2) all the way down using the hand wheel (1).
2. Insert the pipe so that it almost reaches the additional cutter (2) and tighten using the multifunctional wrench (4).

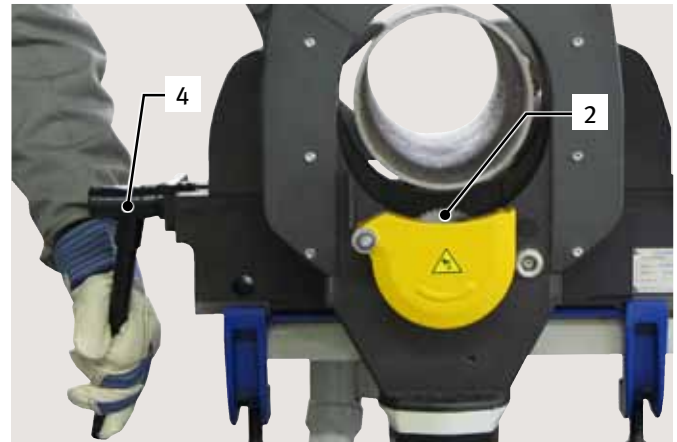

3. Use the handle to turn the motor upwards for about 30° until the saw blade is in cutting position.
4. Turn the hand wheel (1) until the teeth of the additional cutter (2) cover the wall thickness of the pipe.
5. If desired, perform a test cut (Cutting and beveling the pipe, see chap. 9.1.5, p. 42 for machines with AVM, chap. 9.2.4, p. 45 for machines with MVM and chap. 9.3.4, p. 48 for working without AVM/MVM), check the cut and bevel and readjust the hand wheel (1) if necessary.
6. Turn the motor back to its home position.

When working with the AVM: Hold down the STOP button (6), and pivot the motor back into the normal position.

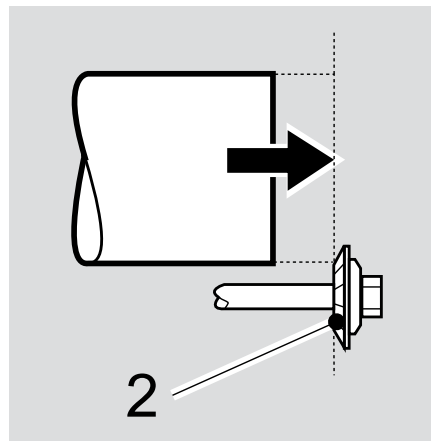
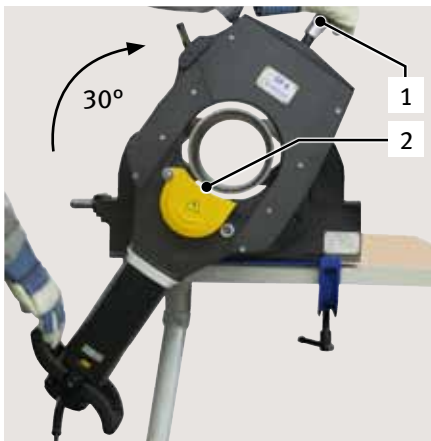

NOTE Scale of the hand wheel: a readjustment by one graduation mark results in a radial feed or bevel alteration of 0.1 mm (0.004 inch), for the GF 6 and GF 20 AVM of 0.2 mm (0.008 inch).

8.4.3 Adjusting the bevel cutter

1. Turn the slide with the bevel cutter (2) all the way down using the hand wheel (1).
2. Insert the pipe so that it almost reaches the bevel cutter (2). The pipe must not project over the cutter. Tighten using the multifunctional wrench (3).

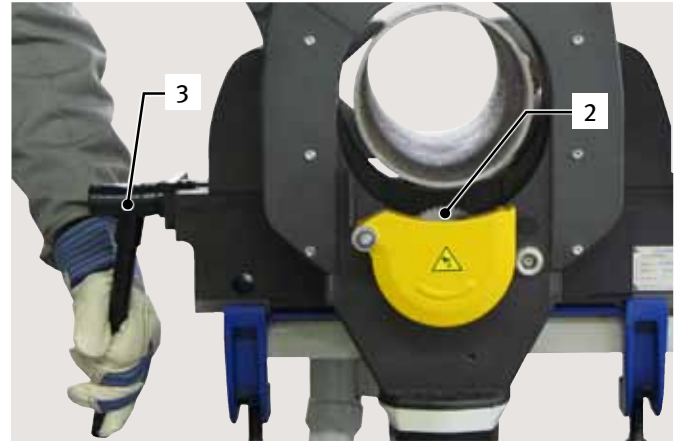

3. Use the handle to turn the motor upwards for about 30° until the bevel cutter is in beveling position.
4. Turn the hand wheel (1) until the teeth of the bevel cutter (2) cover the wall thickness of the pipe and the desired beveling position is reached.
5. If desired, perform a test bevel (beveling the pipe, see chap. 9.1.4, p. 42 for machines with AVM, chap. 9.2.3, p. 44 for machines with MVM and chap. 9.3.3, p. 47 for working without AVM/MVM), check the bevel and readjust the hand wheel (1) if necessary.
6. Turn the motor back to its home position.

When working with the AVM: Hold down the STOP button (6), and pivot the motor back into the normal position.

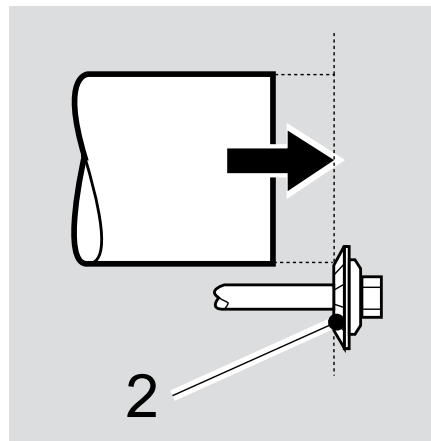
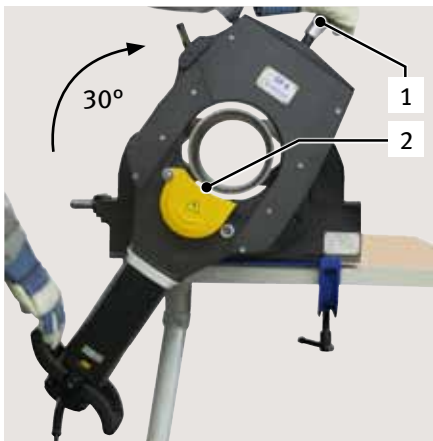



NOTE Scale of the hand wheel: a readjustment by one graduation mark results in a radial feed or bevel alteration of 0.1 mm (0.004 inch), for the GF 6 and GF 20 AVM of 0.2 mm (0.008 inch).

8.5 Selecting the motor speed



NOTE Select low power speed for tough and high-strength materials and large wall thickness.

8.5.1 Standard values for spindle speed and feed force level (AVM)

Pipe material	RPM control setting (1)	Spindle speed (rpm)	Force feed level AVM*  
High-alloy high-quality steels	1 - 2	65	L - 2
Low-alloy high-quality steels	2 - 4	150	L - 4 (GF 20 AVM: 2 - 4)
Structural steel	4 - 6	215 (GF 20 AVM: 163)	5 - 9

* The feed force level and spindle speed may be varied depending on the thickness and diameter of the pipe wall.

IMPORTANT NOTES REGARDING AVM

- ▶ When first starting to process the pipe with the AVM, a low feed force level is recommended which may be increased later. Higher levels result in a higher chip production and possibly also in a higher wear of tools. The intelligent control system of the AVM monitors the feed force continuously depending on the torque and the parameter settings.
- ▶ When cutting thin-walled pipes (wall thickness 3 - 5 mm), always start with level 1 and select a higher level afterwards.
- ▶ Select the feed force level (L - 9) using the / buttons on the AVM display (for standard values, see the table above).



9. OPERATION



DANGER

Machine start-up due to unintentional pressing of the ON/OFF switch or the speed regulator.

Fatal electric shock!

Diverse physical injuries and material damage!

- ▶ Prior to assembly, dismantling, maintenance and adjustment work, disconnect the machine from the mains supply and allow it to run to a stop.



DANGER

When the slide housing is rotating, excess lubricant can get into the motor unit.

Fatal electric shock!

- ▶ Remove excess lubricant from the machine after every step.



WARNING

Flying parts/breaking tool!

Diverse physical injuries and material damage.

- ⊘ **Do not** process the pipe while it is loose in the vice.
- ⊘ **Never** use a damaged or deformed saw blade or bevel cutter.
- ⊘ In the event of tool breakage with a new tool, do not enter the old cut because the tool can break again (for details of what to do in the event of tool breakage, see chap. 11.4.1, p. 55).
- ▶ Clamp the pipe to be cut into the vice.
- ▶ Immediately replace worn-out tools.
- ▶ Ensure that the cutting tools are correctly fitted.
- ▶ Pipe dimension must be set correctly. During cutting, the saw blade must saw through the entire pipe wall.
- ▶ Avoid breaking tool through low (adequate) feed force, correct dimension (see chap. 8.4, p. 35) and speed (see chap. 8.5, p. 38) settings.
- ▶ Hold on to the motor unit tightly by the handle, and guide it with low (adequate) feed force during the machining process.



WARNING

Risk of machine and pipe falling!

Irreversible crushing.

- ▶ Check the machine's position and secure it so it cannot fall.
- ▶ Support pipes using pipe stands.



WARNING

Trapped fingers between the vice/clamping shell and pipe!

Irreversible crushing.

- ⊘ **Do not** insert fingers between the vice/clamping shell and pipe!



ATTENTION

Restarting the machine following blockage!

Diverse physical injuries and material damage.

- ▶ In the event of a blockage, always disconnect the machine from the power supply before clearing it.
- ▶ If necessary, remove any tensioned parts before restarting the machine.



ATTENTION

Vapors when working with lubricants!

Damage to lungs, skin and the environment.

- ▶ Only use original lubricant recommended by Orbitalum Tools.



DANGER

Unexpected start-up!

Serious injury or death.

- ▶ Before connecting the machine to the power supply, check the on/off switch is switched off.



DANGER

Loose/baggy clothing, long hair or jewelry can get caught in rotating machine parts!

Serious injury or death.

- ⊘ During operation, **do not** wear loose/baggy clothing, e.g. neckties.
- ▶ Tie up long hair to prevent it from being caught.



WARNING

Body parts can fit between the cutting tools and the pipe!

Serious injury.

- ⊘ **Do not** place body parts between the cutting tools and the pipe.



WARNING

Flying, hot and sharp-edged chips, pipe surfaces, cutting edges and tools!

Danger of injury to eyes and hands.

- ⊘ **Do not** touch the running tool while the machine is in operation.
- ⊘ **Never** work without the saw chip guard mounted.
- ▶ Wear recommended protective clothing.
- ▶ Only remove chips with tight-fitting safety gloves (in accordance with DIN EN 388).
- ▶ Make sure the chips guard is working.

9.1 Processing the pipe with AVM

For more information on pipe processing with MVM, see chap. 9.2, p. 43.

For manual operation without AVM or MVM, see chap. 9.3, p. 46.

NOTE This processing type is not possible in combination with the RA 2.

IMPORTANT Only operate AVM in combination with the Orbitalum Tools pipe cutters GF 4, GF 6, GF 20, RA 8 or RA 12.
 ⊘ **Do not** connect any other devices to the socket of the AVM.

9.1.1 Shutting down (even in an emergency)



DANGER

EMERGENCY STOP cannot be reached if the operator is not standing correctly in front of the GF 20 AVM!

Diverse physical injuries and material damage.

- ▶ While the housing is rotating only stand to the side of the machine.
- ▶ The EMERGENCY STOP button (12) must be within reach at all times.



DANGER

Pulling the plug does not perform the EMERGENCY STOP function!

Diverse physical injuries and material damage.

- ⊘ **Do not use** crimped cables.
- ▶ Ensure the plug is not obstructed.
- ▶ Simulate an emergency by carrying out a practice plug removal.

IMPORTANT EMERGENCY STOP button (12) on the AVM:
 Only press in an emergency. Pressing the EMERGENCY STOP button (13) interrupts the power supply. Unlock the button to restart.



- ▶ Activate by switching the ON/OFF toggle switch (13). If the ON/OFF toggle switch (13) fails to work, remove the plug from the socket or vacate the danger zone as quickly as possible.

9.1.2 Initial operation



1. Connect the pipe cutter to the socket (1) of the AVM.
2. Connect the mains cable of the AVM to the main power supply.

9.1.3 Cutting the pipe with AVM

IMPORTANT If the pipe cutter was out of operation for a relatively long time:

- ▶ Swivel the cutter motor by 180° (GF 20 AVM: 150°).
- ▶ Switch on the AVM and the pipe cutter (see chap. 9.1.2, p. 41), let the cutter motor run for about 10 seconds.

This relubricates all gear components.

1. Adjust the pipe dimension (see chap. 8.4, p. 35).
2. Adjust the saw blade to the pipe dimension (see chap. 8.4, p. 35).
3. If necessary, tighten the hexagon nut of the saw blade fixture a fraction (see chap. 8.3, p. 33).
4. Adjust the spindle speed and the feed force level (for standard values, (see chap. 8.5.1, p. <?>)).
5. Push the pipe through the vice up to the desired length and clamp it securely.
Support pipes longer than 1 m using a pipe feeder (see chap. 8.1.3, p. 32).

IMPORTANT Pull off the vice handle from the spindle before the slide housing starts rotating.

6. Apply saw blade lubricant to the saw blade:
Recommendation:
 - for GF 20 AVM: prior to every step,
 - up to 2": at least every 3 cuts,
 - over 2" and with chrome and high-quality steel pipes: prior to every cut.

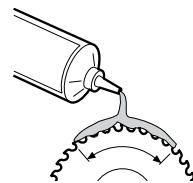

NOTE Use only saw blade lubricant (no oils) from Orbitalum Tools (e.g. GF LUB or GF TOP).
Keep the machine clean. Always remove residue from lubricant from the machine.

NOTE For continuous operation: after cutting loosen the hexagon nut on the bevel cutter to avoid damage caused by tension.

7. Switch pipe cutter on.
8. Press the  START button.

This starts the pipe processing. The cutter automatically shuts off after the complete cut has been made.

9.1.4 Beveling the pipe with AVM

- IMPORTANT** If the pipe cutter was out of operation for a relatively long time:
- ▶ Swivel the cutter motor by 180° (GF 20 AVM: 150°).
 - ▶ Switch on the AVM and the pipe cutter (see chap. 9.1.2, p. 41), let the cutter motor run for about 10 seconds.
- This relubricates all gear components.

1. Adjust the pipe dimension (see chap. 8.4, p. 35).
2. Adjust the bevel cutter to the pipe dimension (see chap. 8.4, p. 35).
3. If necessary, tighten the hexagon nut of the bevel cutter fixture a fraction (see chap. 8.3, p. 33).
4. Adjust the spindle speed and the feed force level (for standard values (see chap. 8.5.1, p. 38).
5. Push the pipe through the vice up to the desired length and clamp it securely.
Support pipes longer than 1 m using a pipe feeder (see chap. 8.1.3, p. 32).

IMPORTANT Pull off the vice handle from the spindle before the slide housing starts rotating.

6. Apply saw blade lubricant to the bevel cutter:
Recommendation:

- for GF 20 AVM: prior to every step,
- up to 2": at least every 3 cuts,
- over 2" and with chrome and high-quality steel pipes: prior to every cut.

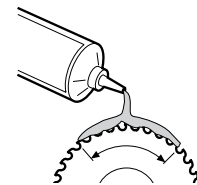

NOTE Use only saw blade lubricant (no oils) from Orbitalum Tools (e.g. GF LUB or GF TOP).
Keep the machine clean. Always remove residue from lubricant from the machine.

NOTE For continuous operation: after beveling, loosen the hexagon nut on the bevel cutter to avoid damage caused by tension.

7. Switch pipe cutter on.
8. Press the  START button.

This starts the pipe processing. The cutter automatically shuts off after the correct bevel has been cut.

9.1.5 Cutting and beveling pipes simultaneously

- Pipes with a wall thickness of up to 7 mm (0.276 inch) can be simultaneously cut and beveled.
- If using an additional cutter, the cutter motor has to be turned around the pipe more slowly than during normal cutting, as two tools are being used at the same time. The procedure is the same as described in chap. 9.1.3, p. 41.

NOTE

- If necessary, lubricate the saw blade and the additional cutter again during work.
- For continuous operation: after cutting, loosen the hexagon nut on the saw blade to avoid damage caused by tension.
- The evenness of the bevel height depends on the roundness of the pipe.

9.2 Processing the pipe with MVM

For more information on pipe processing with AVM, see chap. 9.1, p. 40.
For manual operation without AVM or MVM, see chap. 9.3, p. 46.

NOTE This processing type is not possible in combination with the RA 2 and the GF 20 AVM.

9.2.1 Shutting down (even in an emergency)



DANGER

Pulling the plug does not perform the EMERGENCY STOP function!

Diverse physical injuries and material damage.

- ⊘ **Do not use** crimped cables.
- ▶ Ensure the plug is not obstructed.
- ▶ Simulate an emergency by carrying out a practice plug removal.



- ▶ Activate by switching the ON/OFF toggle switch (12).
If the ON/OFF toggle switch (12) fails to work, remove the plug from the socket or vacate the danger zone as quickly as possible.

9.2.2 Cutting the pipe with MVM

IMPORTANT If the pipe cutter was out of operation for a relatively long time:

- ▶ Turn the cutter motor by 180°.
- ▶ Switch the pipe cutter on and let it run for about 10 seconds.
This relubricates all gear components.

1. Adjust the pipe dimension (see chap. 8.4, p. 35).
2. Adjust the saw blade to the pipe dimension (see chap. 8.4, p. 35).
3. If necessary, tighten the hexagon nut of the saw blade fixture a fraction (see chap. 8.3, p. 33).
4. Adjust the spindle speed (see chap. 8.5.1, p. 38).
5. Push the pipe through the vice up to the desired length and clamp it securely.
Support pipes longer than 1 m using a pipe feeder (see chap. 8.1.3, p. 32).

IMPORTANT Pull off the vice handle from the spindle before the slide housing starts rotating.

6. Apply saw blade lubricant to the saw blade:
Recommendation:
 - up to 2": at least every 3 cuts,
 - over 2" and with chrome and high-quality steel pipes: prior to every cut.

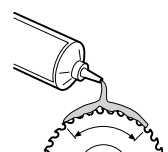

NOTE Use only saw blade lubricant (no oils) from Orbitalum Tools (e.g. GF LUB or GF TOP).
Keep the machine clean. Always remove residue from lubricant from the machine.

NOTE For continuous operation: after cutting loosen the hexagon nut on the bevel cutter to avoid damage caused by tension.



7. Switch pipe cutter on.
8. Carefully turn the hand wheel (1) of the MVM clockwise until the pipe wall has been pierced through.
9. Continue turning steadily until the pipe has been cut off.
10. Switch the motor off and allow the machine to run to a stop.

9.2.3 Beveling the pipe with MVM

IMPORTANT If the pipe cutter was out of operation for a relatively long time:

- ▶ Turn the cutter motor by 180°.
- ▶ Switch the pipe cutter on and let it run for about 10 seconds.

This relubricates all gear components.

1. Adjust the pipe dimension (see chap. 8.4, p. 35).
2. Adjust the bevel cutter to the pipe dimension (see chap. 8.4, p. 35).
3. If necessary, tighten the hexagon nut of the bevel cutter fixture a fraction (see chap. 8.3, p. 33).
4. Adjust the spindle speed (see chap. 8.5.1, p. 38).
5. Push the pipe through the vice up to the desired length and clamp it securely. Support pipes longer than 1 m using a pipe feeder (see chap. 8.1.3, p. 32).

IMPORTANT Pull off the vice handle from the spindle before the slide housing starts rotating.

6. Apply saw blade lubricant to the bevel cutter:
Recommendation:

- up to 2": at least every 3 cuts,
- over 2" and with chrome and high-quality steel pipes: prior to every cut.

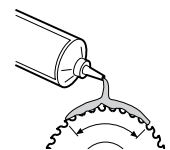

NOTE Use only saw blade lubricant (no oils) from Orbitalum Tools (e.g. GF LUB or GF TOP). Keep the machine clean. Always remove residue from lubricant from the machine.

NOTE For continuous operation: after beveling, loosen the hexagon nut on the bevel cutter to avoid damage caused by tension.



7. Switch pipe cutter on.
8. Carefully turn the hand wheel (1) of the MVM clockwise until the pipe wall has been pierced through.
9. Continue turning steadily until the pipe has been beveled completely.
10. Switch the motor off and allow the machine to run to a stop.

9.2.4 Cutting the pipe with MVM and beveling it simultaneously

- Pipes with a wall thickness of up to 7 mm (0.276 inch) can be simultaneously cut and beveled.
- If using an additional cutter, the cutter motor has to be turned around the pipe more slowly than during normal cutting, as two tools are being used at the same time. The procedure is the same as described in chap. 9.2.2, p. 43.

NOTE

- If necessary, lubricate the saw blade and the additional cutter again during work.
 - For continuous operation: after cutting, loosen the hexagon nut on the saw blade to avoid damage caused by tension.
 - The evenness of the bevel height depends on the roundness of the pipe.
-

9.3 Processing the pipe manually

For more information on pipe processing with AVM, see chap. 9.1, p. 40.
 For more information on pipe processing with MVM, see chap. 9.2, p. 43.

9.3.1 Shutting down (even in an emergency)



DANGER

Pulling the plug does not perform the EMERGENCY STOP function!

Diverse physical injuries and material damage.

- ⊘ Do not use crimped cables.
- ▶ Ensure the plug is not obstructed.
- ▶ Simulate an emergency by carrying out a practice plug removal.



- ▶ Activate by switching the ON/OFF toggle switch (12).
 If the ON/OFF toggle switch (12) fails to work, remove the plug from the socket or vacate the danger zone as quickly as possible.

9.3.2 Cutting the pipe manually

IMPORTANT If the pipe cutter was out of operation for a relatively long time:

- ▶ Turn the cutter motor by 180°.
- ▶ Switch the pipe cutter on and let it run for about 10 seconds.

This relubricates all gear components.

1. Adjust the pipe dimension (see chap. 8.4, p. 35).
2. Adjust the saw blade to the pipe dimension (see chap. 8.4, p. 35).
3. If necessary, tighten the hexagon nut of the saw blade fixture a fraction (see chap. 8.3, p. 33).
4. Adjust the spindle speed (see chap. 8.5.1, p. 38).
5. Push the pipe through the vice up to the desired length and clamp it securely.
 Support pipes longer than 1 m using a pipe feeder (see chap. 8.1.3, p. 32).

IMPORTANT Pull off the vice handle from the spindle before the slide housing starts rotating.

6. Apply saw blade lubricant to the saw blade:
 Recommendation:
 - up to 2": at least every 3 cuts,
 - over 2" and with chrome and high-quality steel pipes: prior to every cut.

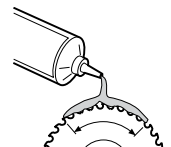

NOTE Use only saw blade lubricant (no oils) from Orbitalum Tools (e.g. GF LUB or GF TOP).
 Keep the machine clean. Always remove residue from lubricant from the machine.

NOTE For continuous operation: after cutting loosen the hexagon nut on the bevel cutter to avoid damage caused by tension.

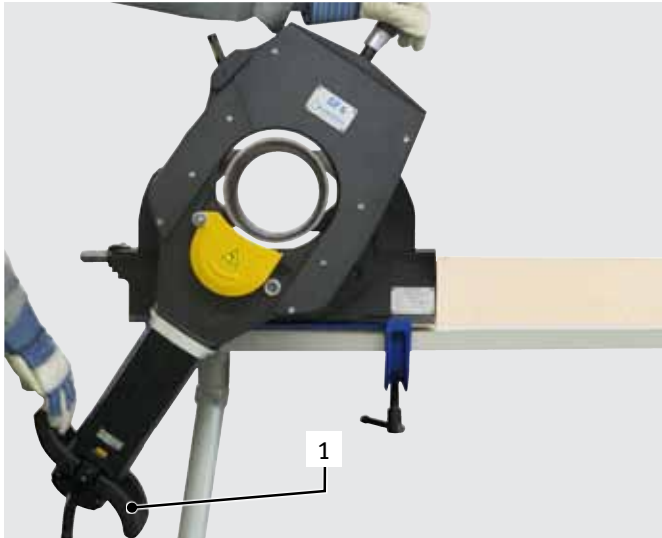

7. Switch the motor on.
8. Carefully turn the motor clockwise using the handle (1) until the pipe wall has been pierced through.
9. Continue turning steadily until the pipe has been cut off.
10. Switch the motor off and allow the machine to run to a stop.

9.3.3 Beveling the pipe manually

IMPORTANT If the pipe cutter was out of operation for a relatively long time:

- ▶ Turn the cutter motor by 180°.
- ▶ Switch the pipe cutter on and let it run for about 10 seconds.

This relubricates all gear components.

1. Adjust the pipe dimension (see chap. 8.4, p. 35).
2. Adjust the bevel cutter to the pipe dimension (see chap. 8.4, p. 35).
3. If necessary, tighten the hexagon nut of the bevel cutter fixture a fraction (see chap. 8.3, p. 33).
4. Adjust the spindle speed (see chap. 8.5.1, p. 38).
5. Push the pipe through the vice up to the desired length and clamp it securely.
Support pipes longer than 1 m using a pipe feeder (see chap. 8.1.3, p. 32).

IMPORTANT Pull off the vice handle from the spindle before the slide housing starts rotating.

6. Apply saw blade lubricant to the bevel cutter:

Recommendation:

- up to 2": at least every 3 cuts,
- over 2" and with chrome and high-quality steel pipes: prior to every cut.

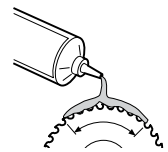

NOTE Use only saw blade lubricant (no oils) from Orbitalum Tools (e.g. GF LUB or GF TOP).
Keep the machine clean. Always remove residue from lubricant from the machine.

NOTE For continuous operation: after beveling, loosen the hexagon nut on the bevel cutter to avoid damage caused by tension.

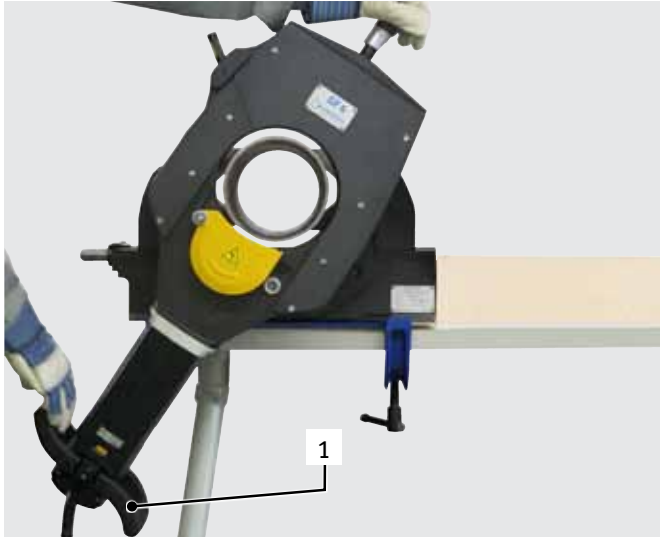

7. Switch the motor on.
8. Carefully turn the motor clockwise using the handle (1) until the pipe wall has been pierced through.
9. Continue turning steadily until the pipe has been beveled completely.
10. Switch the motor off and allow the machine to run to a stop.

9.3.4 Cutting the pipe manually and beveling it simultaneously

- Pipes with a wall thickness of up to 7 mm (0.276 inch) can be simultaneously cut and beveled.
- If using an additional cutter, the cutter motor has to be turned around the pipe more slowly than during normal cutting, as two tools are being used at the same time. The procedure is the same as described in chap. 9.3.2, p. 46.

NOTE

- If necessary, lubricate the saw blade and the additional cutter again during work.
- For continuous operation: after cutting, loosen the hexagon nut on the saw blade to avoid damage caused by tension.
- The evenness of the bevel height depends on the roundness of the pipe.

10. CONTINUOUS COOLING SYSTEM FOR THE GF 20 AVM

This cooling system which extends the life of the cutter blade and provides a better quality finish on the pipes, is not supplied in the standard scope of delivery for the GF 20 AVM. It can, however, be ordered using the code number provided and retrofitted onto the machine (Ordering and technical data, see chap. 3.7.12, p. 20).

10.1 Features

Infinitely variable. The system is cooled with compressed air fed through a cooling pipe. The cooling air rate can be configured to the optimum level for your application. Also suitable for cutting plastic pipes. Cooling without coolants. The saw blade is constantly cooled during the cutting process with cold air (to -37°C).

The amount of warm air flowing out into the cooling pipe can be set/adjusted by turning the valve (4). This way the operator can control the temperature of the cold air output.

NOTE The valve (4) can only be adjusted when the machine is at a complete stop.
 ► Make sure that the flexible hose (2) is aligned toward the teeth of the saw blade.

NOTE The compressed air hose must not be located behind the machine since this would pose a risk of jamming. The compressed air hose may never be tangled.

IMPORTANT The cooling system is only to be switched on when processing is being performed.

10.2 Position of the cooling system on the GF 20 AVM

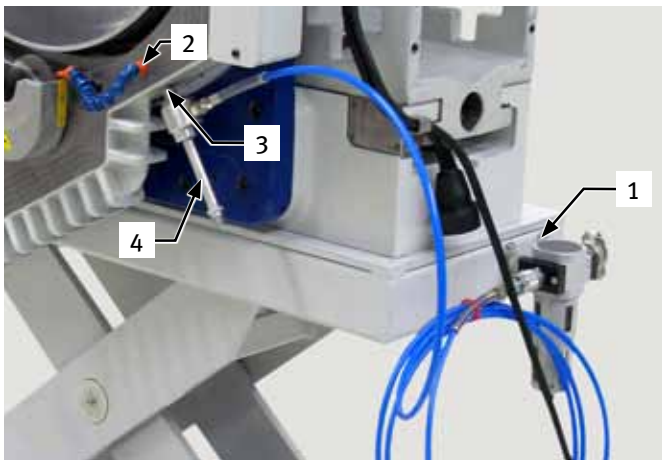

The continuous cooling system is mounted on the right-hand side of the GF 20's lifting bench (1), and on the GF 20 slide at the front (2+3). The machine already has the appropriate mounting holes.

10.3 Product design

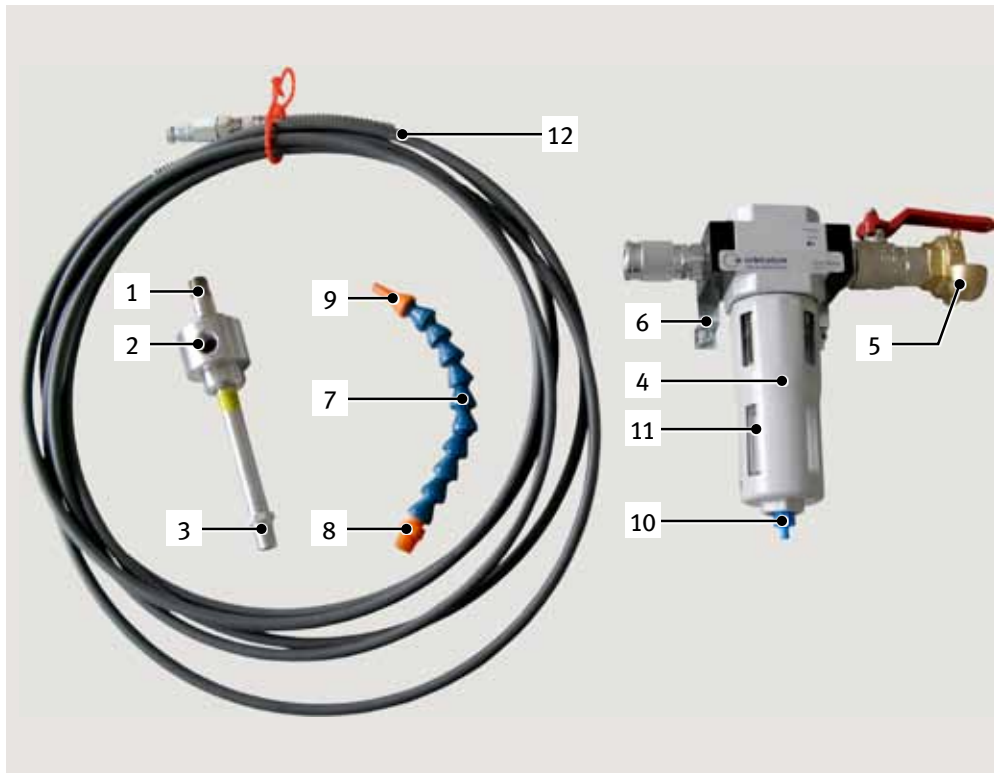

1. Cold air outputs 1/4" – 18 NPT
2. Cooling pipe
3. Warm air outputs 1/4" – 18 NPT
4. Filter
5. Air intake compressed air attachment, 1/2" coupling disk
6. Bracket for securing cooling system to side of lifting bench
7. Flexible hose
8. Air intake for flexible hose G 1/4"
9. Air output for flexible hose
10. Manual rotating condensation blow-out
11. Filter indicator
12. Compressed air hose

10.4 Assembly

1. Use an Allen wrench and 4 M5x12 cylinder head screws (1) to mount the filter unit (2) to the right-hand side of the lifting bench. There is no need to drill mounting holes since the lifting bench comes with 4 threaded holes already drilled.
2. Connect the quick-disconnect coupler of the compressed air hose (3) to the air outlet of the filter unit (4).



3. Connect the cooling pipe to the air output (7) by screwing it into the 1/4" - 18 NPT threaded hole.



4. Use a fork ring wrench to screw the output side of the compressed air hose (8) into the cooling pipe.
5. The flexible hose (9) has G1/4" threads in it for screwing onto the front side of the slide.



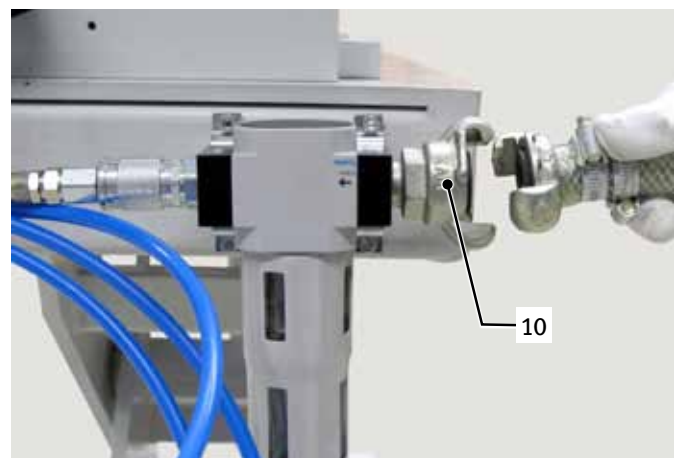

6. Next, flex the flexible hose (9) so that the cutter blade and/or bevel cutter has optimal compressed air feed during subsequent processing.
7. Connect the compressed air attachment (10) (1/2" coupling disk) to the compressed air supply (5.5 to 8.0 bars).



11. SERVICING, MAINTENANCE, TROUBLESHOOTING

NOTE Some of the work mentioned depends a great deal on the use and on the ambient conditions. The cycles specified are minimum specifications. In individual cases, differing maintenance cycles are possible. To ensure machine safety, carry out maintenance with VDE testing on an annual basis. If the machine does not function as previously described, the machine must also be sent into an authorized service center.

 **DANGER** **Danger of death by electric shock!**
 Non-observance could result in death or serious injury.
 ► Before the maintenance work is carried out, allow the machine to run to a stop and pull the mains plug.

 **DANGER** **Risk of electric shock due to poor electrics!**
 Fatal electric shock.
 ► Before the maintenance work is carried out, allow the machine to run to a stop and pull the mains plug.
 ► Repair and maintenance work on the electrical equipment may only be carried out by a qualified electrician.

11.1 Maintenance

Interval	Activity
Before starting work	<ul style="list-style-type: none"> ► Remove chips and dirt from the saw blade. ► Keep the vent holes free from chips. ► Check the oil level of the gear and top up if necessary (see chap. 11.2, p. 53). ► Make sure that the felt ring (1) is on the locking sleeve, replace if necessary. Felt ring for GF 4, GF 6, RA 2, RA 8, RA 12: Code 790 041 416. ► Felt ring for GF 20 AVM: Code 790 050 168.
Every time the cutter is cleaned Every time the tool is changed	<ul style="list-style-type: none"> ⊗ Do not use compressed air to clean the area at the end of the shaft marked with an arrow as the rotary shaft seal may otherwise be damaged by chips. ► Use a cloth or brush to clean the end of the shaft.
Every week	<ul style="list-style-type: none"> ► Clean and oil: <ul style="list-style-type: none"> • The spindle of the hand wheel (1) • The sliding block (2) • The guide bush (3) • Vice tracks (4) • Vice spindle (5)

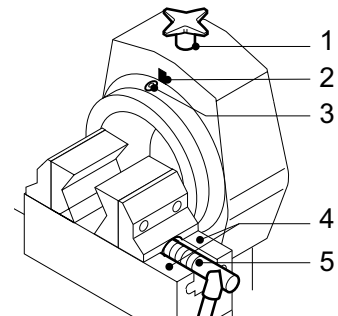
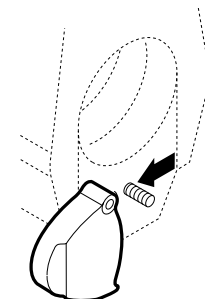

11.1.1 Laser

- No maintenance for the laser required.
- For the Laser is no service allowed.
- The laser has to be returned to the factory for any service or repair.
- It is not allowed to open, modify or to remove protective covers or housings except for battery change.

11.2 Checking the oil level of the gear and topping up

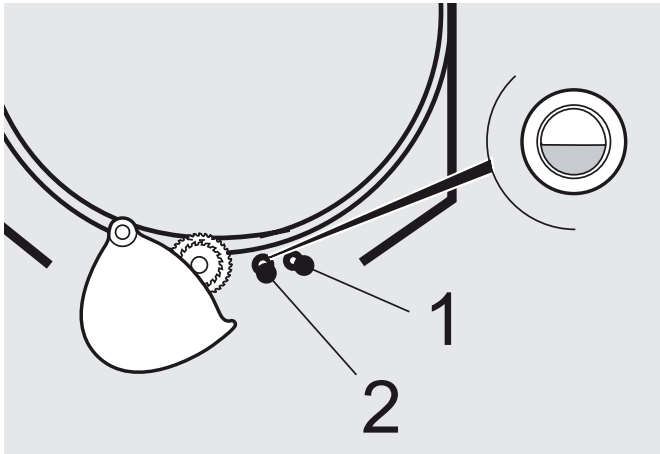

The gears of the pipe cutters have an oil level indicator. The oil level should be visible in the middle of the inspection glass.

1. Check the oil level through the inspection glass (2) and top up if necessary.
2. To top up: unscrew the oil filler screw (1). Fill with special Orbitalum Tools gear oil.
3. Re-insert and tighten the oil filler screw.

11.3 Cleaning the slide guide



WARNING

Danger of being injured by a not sufficiently secured slide!

⊘ **Never** dismount the slide by pulling it downwards.

▶ Always tighten the safety screw when assembling the slide.

1. Remove the safety screw (1).
2. Turn the slide housing upwards by 180°.
3. Turn the hand wheel (2) counterclockwise.
4. Pull out the slide (3) with the motor upwards.
5. Clean the guides of the slide housing and slide. Lightly lubricate both parts using HD 30 engine oil.
6. Remount the slide. Insert and tighten the safety screw (1).



Position of the safety screw for the GF 4 and GF 6 (AVM/MVM).



Position of the safety screw for the GF 20 AVM, RA 2, RA 6, RA 8, RA 12 (AVM/MVM).



11.4 Mounting instruction for laser/Change of batteries

It is not allowed to open, to modify or to remove protective covers or housings except for battery change.

11.4.1 GF 4, GF 6 (AVM/MVM)

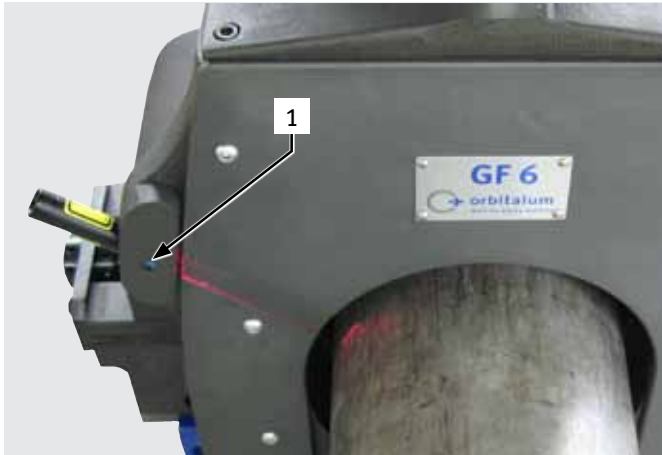

1. Loosen the threaded pin M6x5 (1) (Code 445 001 210) by using allen key SW4 to remove the laser from the slide housing.
2. Exchange the batteries.
3. After putting the laser in the slide housing the laser has to be adjusted and the threaded pin M6x5 (Code 445 001 210) has to be tightened with allen key SW4.

11.5 What to do if? – General trouble-shooting

Problem	Possible cause	Remedy
The motor is not running.	The overload protection relay has tripped.	▶ With the switch on "0", switch the pipe cutter back on and allow to run at idle for about 1 minute.
	The restart inhibitor has tripped.	▶ Set the switch to "0", then switch the pipe cutter back on.
The pipe cutter will not turn.	Pipe diameter not correctly set.	▶ Set the pipe dimension correctly (see chap. 8.4, p. 35).
The saw blade is not cutting and is slipping through.	Hexagon nut on the saw blade shaft not tightened.	▶ Tighten the hexagon nut.
The saw blade is not cutting.	The saw blade has been inserted the wrong way round.	▶ Insert the saw blade correctly. The labelling of the saw blade must be visible when viewed from the front of the machine.
It is no longer possible to set the pipe dimension.	The slide guide is dirty.	▶ Clean the slide guide (see chap. 11.3, p. 53).
The feeder does not start.	Feed force level or motor speed too low.	▶ Increase feed force level or motor RPMs.
Tool breakage.	Feed rate and cutting speed too high.	▶ See chap. 11.4.1 for details of the remedy.

11.5.1 What to do in the event of tool breakage

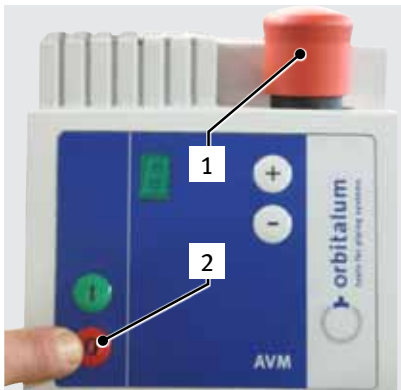

- ⊘ Stop the machine.
- ▶ Press the EMERGENCY STOP button (1), remove the mains plug and undo the hexagon nut on the saw blade.
- ▶ Reinsert the mains plug and engage the EMERGENCY STOP button (1).
- ▶ Keep pressing the red stop button (2) on the AVM and, if required, turn the machine back to its starting position with additional assistance (another person).
- ▶ Fit a new tool; remove the mains plug before replacing the tool, see from chap. 8.3, p. 33 ff for details of saw blade milling cutter fitting).

NOTE If a new tool breaks, do not enter the old cut as the tool can break again.

11.6 Error messages/trouble-shooting AVM

In case of faults concerning the AVM, the machine will stop automatically. The display will flash at 1-second intervals, alternately showing "F" and a figure from 1 to 6. Before restarting the AVM, it has to be disconnected from the mains supply by pressing the EMERGENCY OFF button or by pulling the mains plug.

Error message/fault	Possible cause	Remedy
Alert F1: Cutter motor overload.	Feed force level too high.	▶ Select a lower feed force level.
Alert F2: Feed motor overload.	Feed force level too high.	▶ Select a lower feed force level.
	Pipe dimension not correctly set.	▶ Set the pipe dimension correctly (see chap. 8.4, p. 35).
	Chips between slide housing and pipe.	▶ Remove the chips.
	The slide housing is running sluggishly.	▶ Make the slide housing run smoothly.
Alert F3: The cutter motor stops during processing.	Obstacle in the swiveling range.	▶ Remove the obstacle.
	Power supply of the cutter motor interrupted.	▶ Check the connecting cable and the plug connections.
Alert F4: Internal control error.	The overload protection relay of the cutter motor has tripped.	▶ With the switch on "0", switch the pipe cutter back on and allow to run at idle for about 1 minute.
	The processor is defective.	▶ Contact the service department.
Alert F5: Overheating.	The temperature of the control system is too high.	▶ Self-regulating after cooling down.
Alert F6: Internal control error.	Wrong basic setting.	▶ Contact the service department.
No alert: AVM does not start.	The cutter motor is not running or is not running long enough.	▶ The cutter motor must be running for at least 5 seconds before the AVM can be started.
The feed stops at the cut-in area.	Blocking by chips.	▶ Remove the chips.
	Pipe dimension not correctly set.	▶ Correct the adjustment.
	Saw blade worn out.	▶ Insert new saw blade.

Error message/fault	Possible cause	Remedy
The feed does not stop at the stop position. Display: No decimal point at the stop position.	Light barrier or reflector defective.	▶ Replace the defective parts (contact the service department, if necessary).
	Light barrier or reflector dirty.	▶ Clean the dirty parts.

After having remedied the cause of malfunction, the AVM has to be reconnected to the mains supply. After having switched off the cutter motor (to position "0"), it may be restarted.

11.7 Servicing/customer service

For ordering spare parts, refer to the separate spare parts list.
For troubleshooting, please contact the branch responsible directly.

Please indicate the following details:

- Type of machine:
 - GF 4, GF 4 AVM or GF 4 MVM
 - GF 6, GF 6 AVM or GF 6 MVM
 - GF 20 AVM
 - RA 2
 - RA 8, RA 8 AVM or RA 8 MVM
 - RA 12, RA 12 AVM or RA 12 MVM
- Machine no.: *(see type plate)*

12. EU DECLARATION OF CONFORMITY

12.1 GF 4, GF 6, RA 2, RA 8, RA 12 (Standard/MVM)



EG-Konformitätserklärung
Declaration of conformity
Dichiarazione di conformità
Déclaration de conformité
Declaración de conformidad

Orbitalum Tools GmbH
Josef-Schüttler-Straße 17
78224 Singen, Deutschland
Tel.: +49 (0) 77 31 792-0
Fax: +49 (0) 77 31 792-524

As in appendix II A of the EC Machinery Directive 2006/42/EC and the EMC Directive 2004/108/EC

Die Bauart der Maschine:
The following product:
Il seguente prodotto:
Le produit suivant:
El producto siguiente:

GF 4 Pipe Cutting and Beveling Machine*
GF 4 MVM Pipe Cutting and Beveling Machine
with Manual Feed Module*
RA 2 Pipe Cutting and Beveling Machine*
GF 6 Pipe Cutting and Beveling Machine*
GF 6 MVM Pipe Cutting and Beveling Machine
with Manual Feed Module*
RA 8 Pipe Cutting and Beveling Machine*
RA 8 MVM Pipe Cutting and Beveling Machine
with Manual Feed Module*
RA 12 Pipe Cutting and Beveling Machine*
RA 12 MVM Pipe Cutting and Beveling Machine
with Manual Feed Module*

Seriennummer:
Series number:
Numero di serie:
Nombre de série:
Número de serie:

Baujahr / Year / Anno / Année / Año:

ist entwickelt, konstruiert and gefertigt in Übereinstimmung mit folgenden EG-Richtlinien:
was designed, constructed and manufactured in accordance with the following EC guidelines:
è stata progettato costruito e commercializzato in osservanza delle seguenti Direttive:
a été dessiné, produit et commercialisé selon les Directives suivantes:
ha sido proyectado construido y comercializado bajo observación de las siguientes Directivas:

EG-Maschinen-Richtlinie 2006/42/EG (MaschR)
EMV-Richtlinie 2004/108/EG

Folgende harmonisierte Normen sind angewandt:
The following harmonized norms have been applied:
Le seguenti norme armonizzate ove applicabili:
Les normes suivantes harmonisées où applicables:
Las siguientes normas armonizadas han sido aplicadas:

EN ISO 13849-1: 2008
EN ISO 13849-2: 2008
EN ISO 12100: 2010
EN 1037: 2008
EN 60745: 2009
EN 61029-1: 2009

* including all accessories of Orbitalum Tools, e.g. the pipe feeder base and extension units, the mobile workstation, etc.

Authorised to compile the technical file is Mr. Gerd Riegraf, Orbitalum Tools GmbH, D-78224 Singen.

Markus Tamm
Managing Director

Hasan Caglar
Manager Division Process

Singen, 22.01.2010

12.2 GF 4 AVM, GF 6 AVM, RA 8 AVM, RA 12 AVM

EG-Konformitätserklärung
 Declaration of conformity
 Dichiarazione di conformità
 Déclaration de conformité
 Declaración de conformidad

Orbitalum Tools GmbH
 Josef-Schüttler-Straße 17
 78224 Singen, Deutschland
 Tel.: +49 (0) 77 31 792-0
 Fax: +49 (0) 77 31 792-524

As in appendix II A of the EC Machinery Directive 2006/42/EC and the EMC Directive 2004/108/EC

Die Bauart der Maschine:
 The following product:
 Il seguente prodotto:
 Le produit suivant:
 El producto siguiente:

GF 4 AVM Pipe Cutting and Beveling Machine
 with Automatic Feed Module*
GF 6 AVM Pipe Cutting and Beveling Machine
 with Automatic Feed Module*
RA 8 AVM Pipe Cutting and Beveling Machine
 with Automatic Feed Module*
RA 12 AVM Pipe Cutting and Beveling Machine
 with Automatic Feed Module*

Seriennummer:
 Series number:
 Numero di serie:
 Nombre de série:
 Número de serie:

Baujahr / Year / Anno / Année / Año:

ist entwickelt, konstruiert and gefertigt in Übereinstimmung mit folgenden EG-Richtlinien:
 was designed, constructed and manufactured in accordance with the following EC guidelines:
 è stata progettato costruito e commercializzato in osservanza delle seguenti Direttive:
 a été dessiné, produit et commercialisé selon les Directives suivantes:
 ha sido proyectado construido y comercializado bajo observación de las siguientes Directivas:

EG-Maschinen-Richtlinie 2006/42/EG (MaschR)
EMV-Richtlinie 2004/108/EG

Folgende harmonisierte Normen sind angewandt:
 The following harmonized norms have been applied:
 Le seguenti norme armonizzate ove applicabili:
 Les normes suivantes harmonisées où applicables:
 Las siguientes normas armonizadas han sido aplicadas:

EN ISO 13849-1: 2008
EN ISO 13849-2: 2008
EN ISO 12100: 2010
EN 1037: 2008
EN 60745: 2009
EN 61029-1: 2009

* including all accessories of Orbitalum Tools, e.g. the pipe feeder base and extension units, the mobile workstation, etc.

Authorised to compile the technical file is Mr. Gerd Riegraf, Orbitalum Tools GmbH, D-78224 Singen.

Markus Tamm
 Managing Director

Hasan Caglar
 Manager Division Process

Singen, 22.01.2010

12.3 GF 20 AVM



EG-Konformitätserklärung
Declaration of conformity
Dichiarazione di conformità
Déclaration de conformité
Declaración de conformidad

Orbitalum Tools GmbH
Josef-Schüttler-Straße 17
78224 Singen, Deutschland
Tel.: +49 (0) 77 31 792-0
Fax: +49 (0) 77 31 792-524

As in appendix II A of the EC Machinery Directive 2006/42/EC and the EMC Directive 2004/108/EC

Die Bauart der Maschine:
The following product:
Il seguente prodotto:
Le produit suivant:
El producto siguiente:

**GF 20 AVM Pipe Cutting and Beveling Machine
with Automatic Feed Module***

Seriennummer:
Series number:
Numero di serie:
Nombre de série:
Número de serie:

Baujahr / Year / Anno / Année / Año:

ist entwickelt, konstruiert und gefertigt in Übereinstimmung mit folgenden EG-Richtlinien:
was designed, constructed and manufactured in accordance with the following EC guidelines:
è stata progettato costruito e commercializzato in osservanza delle seguenti Direttive:
a été dessiné, produit et commercialisé selon les Directives suivantes:
ha sido proyectado construido y comercializado bajo observación de las siguientes Directivas:

**Maschinen-Richtlinie (2006/42/EG)
EMV-Richtlinie (2004/108/EG)**

Folgende harmonisierte Normen sind angewandt:
The following harmonized norms have been applied:
Le seguenti norme armonizzate ove applicabili:
Les normes suivantes harmonisées où applicables:
Las siguientes normas armonizadas han sido aplicadas:

**EN ISO 13849-1: 2008
EN ISO 13849-2: 2008
EN ISO 12100: 2010
EN 1037: 2008
EN 60204-1: 2006**

* including all accessories of Orbitalum Tools, e.g. the pipe feeder base and extension units, the mobile workstation, etc.

Authorised to compile the technical file is Mr. Gerd Riegraf, Orbitalum Tools GmbH, D-78224 Singen.

Markus Tamm
Managing Director

Hasan Caglar
Manager Division Process

Singen, 22.01.2010

**We value
your opinion!**

Please send us
your comments
and queries.



Orbitalum Tools GmbH
Josef-Schuettler-Str. 17
78224 Singen, Germany
Tel. +49 (0) 77 31 792-0
Fax +49 (0) 77 31 792-524
tools@orbitalum.com
www.orbitalum.com

790 142 766_02 | EN | 12.11
© Orbitalum Tools GmbH
D-78224 Singen
Printed in Germany