

Operating Instructions

MTG 250d, 320d, 400d, 500d
MHP 400d G ML
MHP 500d G ML M
MTB 250i, 320i, 330i, 400i, 550i G ML
MTW 250d, 400d, 500d, 700d
MHP 500d W ML, 700d W ML
MHP 700d W ML M
MTB 250i, 330i, 400i, 500i W ML
MTB 700i W ML
MTG 400d K4
MTW 500d K4

DE | Bedienungsanleitung

EN | Operating Instructions

ES | Manual de instrucciones

FR | Instructions de service

IT | Istruzioni per l'uso

PT-BR | Manual de instruções



Inhaltsverzeichnis

Sicherheit.....	4
Bestimmungsgemäße Verwendung.....	4
Sicherheit.....	4
Gefahr durch Schweißrauch.....	5
MTG d, MTW d, MHP d - Allgemeines.....	6
Up/Down Funktion.....	6
JobMaster Funktion.....	6
MTG 400d K4, MTW 500d K4 - Allgemeines.....	8
Allgemeines.....	8
Richtwerte für Absauggeräte.....	8
Luftstromregler.....	8
Up/Down Funktion.....	9
Verschleißteile am Brennerkörper montieren.....	10
MTG d, MTW d - Verschleißteile am Brennerkörper montieren.....	10
MTG 400d K4, MTW 500d K4 - Verschleißteile montieren.....	10
ML-Brennerkörper am MHP-Schlauchpaket montieren.....	12
Multilock-Schweißbrenner zusammenbauen.....	12
Draht-Führungsseelen montieren.....	13
Spann-Nippel überprüfen.....	13
Draht-Führungsseele aus Stahl montieren.....	13
Draht-Führungsseele aus Kunststoff montieren (F, F++).....	15
Kunststoff-Seele montieren (Fronius-Anschluss mit Draht-Führungsdüse).....	16
Draht-Führungsseele aus Kunststoff montieren (Euro).....	17
Inbetriebnahme.....	18
Schweißbrenner anschließen.....	18
Absaugung anschließen.....	18
Brennerkörper des Multilock-Schweißbrenners verdrehen.....	19
Brennerkörper des Multilock-Schweißbrenners wechseln.....	20
Prisma-Halterung für Maschinen-Schweißbrenner.....	21
Pflege und Wartung.....	22
Allgemeines.....	22
Erkennen von defekten Verschleißteilen.....	22
Wartung bei jeder Inbetriebnahme.....	22
Wartung bei jedem Austausch der Draht- /Korbspule.....	23
Fehlerdiagnose, Fehlerbehebung.....	25
Fehlerdiagnose, Fehlerbehebung.....	25
Technische Daten.....	31
Allgemeines.....	31
Schweißbrenner gasgekühlt - MTG 250d - 500d.....	31
Brennerkörper gasgekühlt - MTB 250i, 320i, 330i, 400i, 550i G ML.....	31
Schlauchpaket gasgekühlt - MHP 400d G ML.....	32
Schlauchpaket gasgekühlt - MHP 500d G ML M.....	32
Schweißbrenner wassergekühlt - MTW 250d - 700d.....	32
Brennerkörper wassergekühlt - MTB 250i, 330i, 400i, 500i, 700i W ML.....	33
Schlauchpaket wassergekühlt - MHP 500d, 700d W ML.....	34
Schlauchpaket wassergekühlt - MHP 700d W ML M.....	34
MTG 400d K4.....	35
Absaug-Kennlinie MTG 400d K4.....	35
MTW 500d K4.....	36
Absaug-Kennlinie MTW 500d K4.....	36

Sicherheit

Bestimmungsgemäße Verwendung

Der MIG/MAG Hand-Schweißbrenner ist ausschließlich zum MIG/MAG-Schweißen bei manuellen Anwendungen bestimmt. Eine andere oder darüber hinausgehende Benutzung gilt als nicht bestimmungsgemäß. Für hieraus entstehende Schäden haftet der Hersteller nicht.

Zur bestimmungsgemäßen Verwendung gehört auch

- das Beachten aller Hinweise aus der Bedienungsanleitung
 - die Einhaltung der Inspektions- und Wartungsarbeiten
-

Sicherheit

WARNUNG!

Gefahr durch Fehlbedienung und fehlerhaft durchgeführte Arbeiten.

Schwere Personen- und Sachschäden können die Folge sein.

- ▶ Alle in diesem Dokument beschriebenen Arbeiten und Funktionen dürfen nur von technisch geschultem Fachpersonal ausgeführt werden.
 - ▶ Dieses Dokument vollständig lesen und verstehen.
 - ▶ Sämtliche Sicherheitsvorschriften und Benutzerdokumentationen dieses Gerätes und aller Systemkomponenten lesen und verstehen.
-

WARNUNG!

Gefahr durch elektrischen Strom.

Schwere Personen- und Sachschäden können die Folge sein.

- ▶ Vor Beginn der Arbeiten alle beteiligten Geräte und Komponenten ausschalten und von Stromnetz trennen.
 - ▶ Alle beteiligten Geräte und Komponenten gegen Wiedereinschalten sichern.
-

WARNUNG!

Gefahr durch elektrischen Strom infolge von schadhaften Systemkomponenten und Fehlbedienung.

Schwere Personen- und Sachschäden können die Folge sein.

- ▶ Sämtliche Kabel, Leitungen und Schlauchpakete müssen immer fest angeschlossen, unbeschädigt, und korrekt isoliert sein.
 - ▶ Nur ausreichend dimensionierte Kabel, Leitungen und Schlauchpakete verwenden.
-

WARNUNG!

Rutschgefahr durch Kühlmittel-Austritt.

Schwere Personen- und Sachschäden können die Folge sein.

- ▶ Die Kühlmittel-Schläuche der wassergekühlten Schweißbrenner immer mit dem darauf montierten Kunststoff-Verschluss verschließen, wenn diese vom Kühlgerät oder anderen Systemkomponenten getrennt werden.
-

! WARNUNG!**Gefahr durch heiße Systemkomponenten und / oder Betriebsmittel.**

Schwere Verbrennungen und Verbrühungen können die Folge sein.

- ▶ Vor Beginn der Arbeiten alle heißen Systemkomponenten und / oder Betriebsmittel auf +25 °C / +77 °F abkühlen lassen (beispielsweise Kühlmittel, wassergekühlte Systemkomponenten, Antriebsmotor des Drahtvorschubes, ...).
- ▶ Geeignete Schutzausrüstung tragen (beispielsweise hitzebeständige Schutzhandschuhe, Schutzbrille, ...), wenn ein Abkühlen nicht möglich ist.

! WARNUNG!**Gefahr durch Kontakt mit giftigem Schweißrauch.**

Schwere Personenschäden können die Folge sein.

- ▶ Schweißrauch immer absaugen.
- ▶ Für ausreichend Frischluft-Zufuhr sorgen. Sicherstellen, dass eine Durchlüftungsrate von mindestens 20 m³ (169070.1 US gi) pro Stunde zu jeder Zeit gegeben ist.
- ▶ Im Zweifelsfall die Schadstoffbelastung am Arbeitsplatz durch einen Sicherheitstechniker feststellen lassen.

! VORSICHT!**Gefahr durch Betrieb ohne Kühlmittel.**

Sachschäden können die Folge sein.

- ▶ Wassergekühlte Geräte nie ohne Kühlmittel in Betrieb nehmen.
- ▶ Während des Schweißens sicherstellen, dass ein ordnungsgemäßer Kühlmittel-Durchfluss gegeben ist - bei Verwendung von Fronius-Kühlgeräten ist dies der Fall, wenn im Kühlmittel-Behälter des Kühlgerätes ein ordnungsgemäßer Kühlmittel-Rückfluss ersichtlich ist.
- ▶ Für Schäden aufgrund von Nichtbeachtung der oben angeführten Punkte haftet der Hersteller nicht, sämtliche Gewährleistungsansprüche erlöschen.

Gefahr durch Schweißrauch**! WARNUNG!****Gefahr durch beim Schweißen entstehenden Rauch, der gesundheitsschädliche Gase und Dämpfe enthält.**

Schwere gesundheitliche Schäden können die Folge sein.

- ▶ Ein Schweißbetrieb ohne ein eingeschaltetes Absauggerät ist nicht zulässig.
- ▶ Unter Umständen kann die alleinige Verwendung eines Absaug-Schweißbrenners nicht ausreichen.
In diesem Fall eine zusätzliche Absaugung installieren, um die Schadstoffbelastung am Arbeitsplatz zu verringern.
- ▶ Im Zweifelsfall die Schadstoffbelastung am Arbeitsplatz durch einen Sicherheitstechniker feststellen lassen.

MTG d, MTW d, MHP d - Allgemeines

Up/Down Funktion

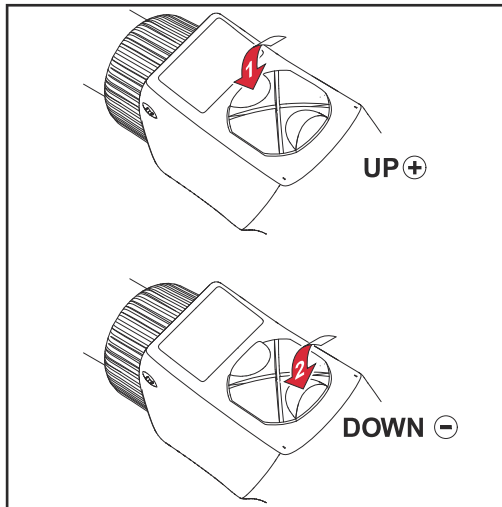

- An der Stromquelle einen der folgenden Parameter anwählen:
 - Drahtgeschwindigkeit
 - Jobnummer
- Parameter mittels Up/Down-Funktion einstellen

WICHTIG! In den Betriebsarten „MIG/MAG Standard- und Puls Synergic Schweißen“ sind zusätzliche Parameter einstellbar.

JobMaster Funktion

WICHTIG! Am JobMaster können codierte Meldungen aufscheinen. Diese entsprechen dem gleichzeitig am Bedienpanel angezeigten Service-Code (siehe Bedienungsanleitung der Stromquelle, Kapitel „Fehlerdiagnose und -behebung“).

Synchro Puls (Option) - kein Symbol am JobMaster leuchtet (siehe Bedienungsanleitung der Stromquelle, Kapitel „MIG/MAG-Schweißen“).

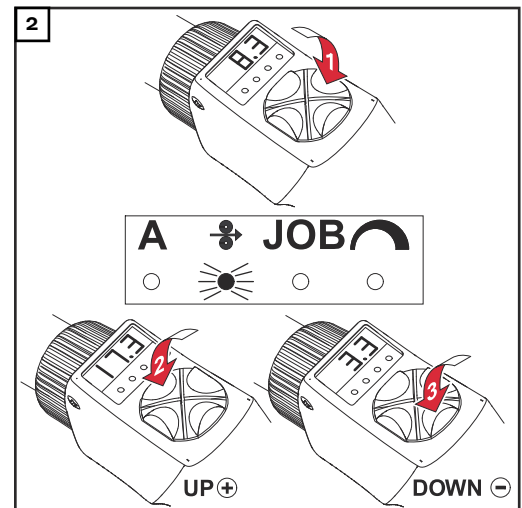
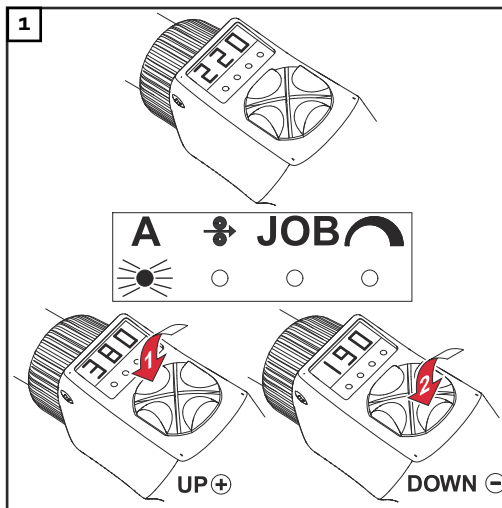

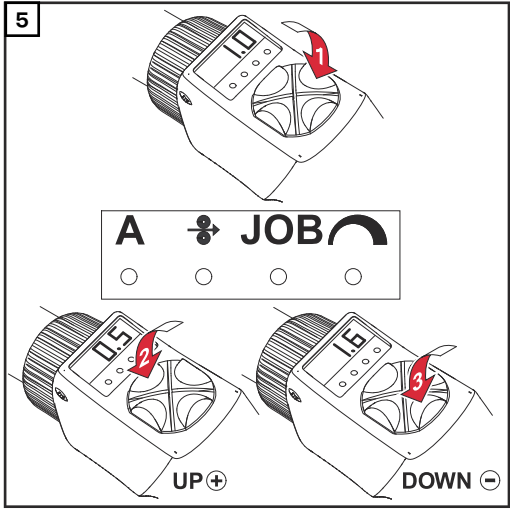
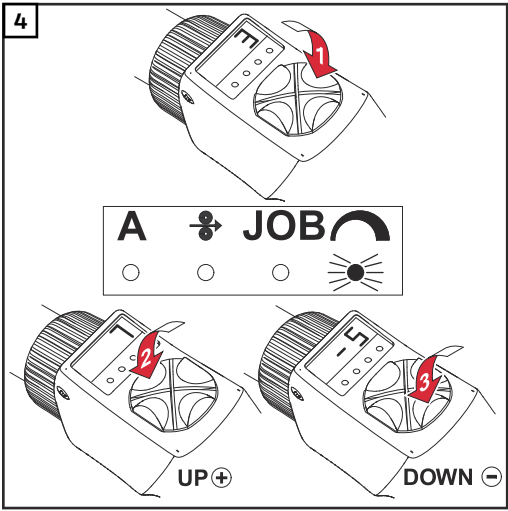
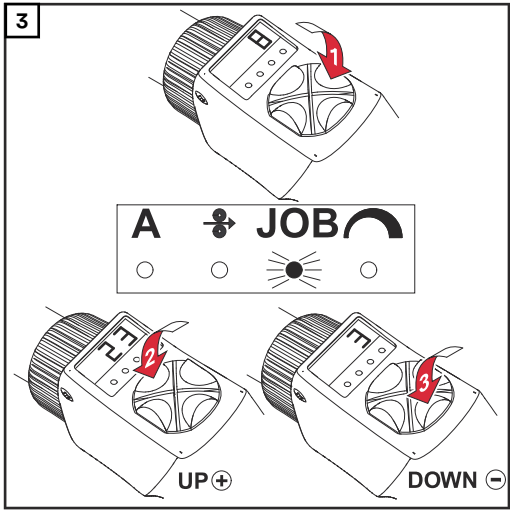

MTG 400d K4, MTW 500d K4 - Allgemeines

Allgemeines

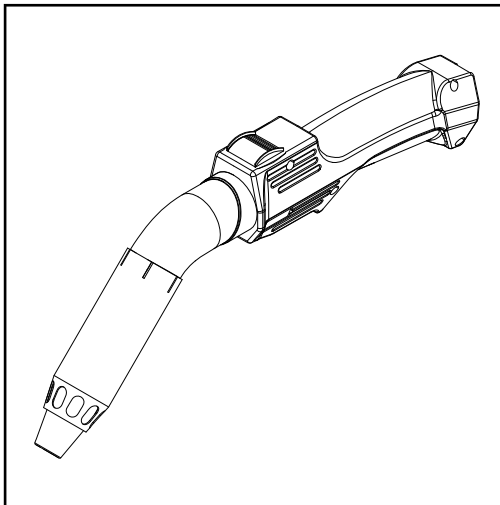

Die Absaug-Schweißbrenner MTG 400d K4 und MTW 500d K4 erfassen den beim Schweißen entstehenden, gesundheitsschädlichen Schweißrauch direkt am Entstehungsort. Der Schweißrauch wird abgesaugt, bevor dieser in den Atembereich des Schweißers gelangt. Gesetzlich vorgeschriebene Werte für die max. Arbeitsplatzkonzentration (MAK) werden eingehalten oder unterschritten.

Richtwerte für Absauggeräte

Das Absauggerät für die Absaug-Schweißbrenner sollte folgende Spezifikationen erfüllen:

Saugleistung	ca. 100 m ³ /h
Unterdruckwerte	zwischen 0,05 und 0,2 bar (zwischen 5000 und 20000 Pa)

Luftstromregler

Mit dem Luftstromregler kann die Menge des abgesaugten Schweißrauchs während des Schweißvorganges stufenlos zwischen 10 und 100 % reguliert werden.

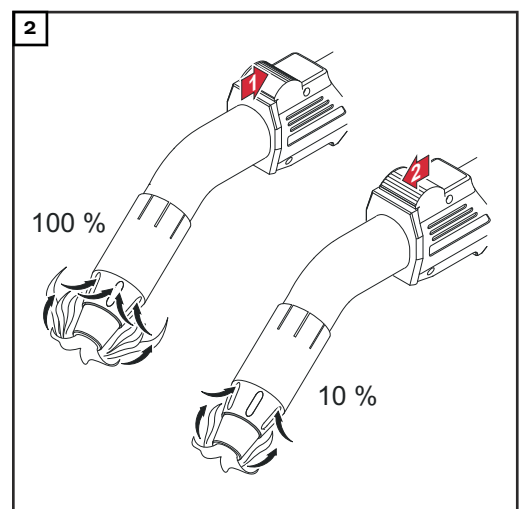
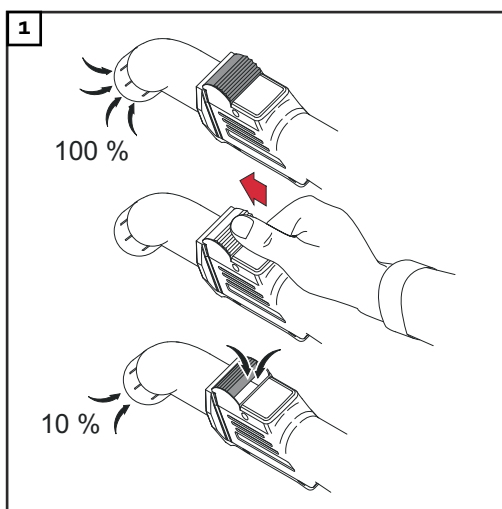

WICHTIG! Die Regulierung der abgesaugten Schweißrauch-Menge ist erforderlich, wenn Schutzgas mit dem Schweißrauch abgesaugt wird (z.B. beim Schweißen in Eckposition).

Up/Down Funktion

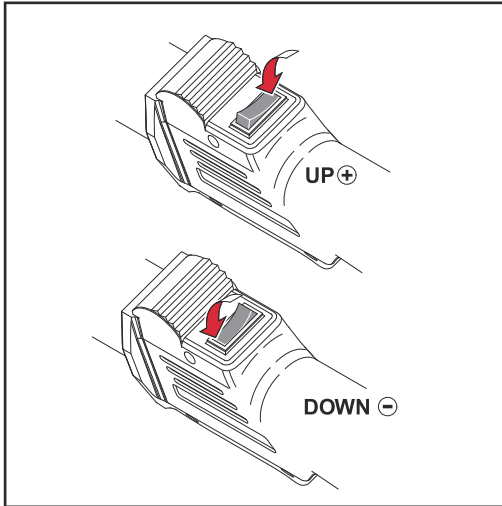

Verschleißteile am Brennerkörper montieren

MTG d, MTW d -
Verschleißteile
am Bren-
nerkörper mon-
tieren

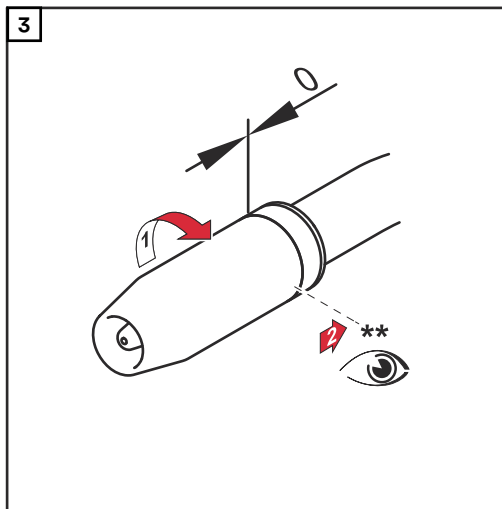
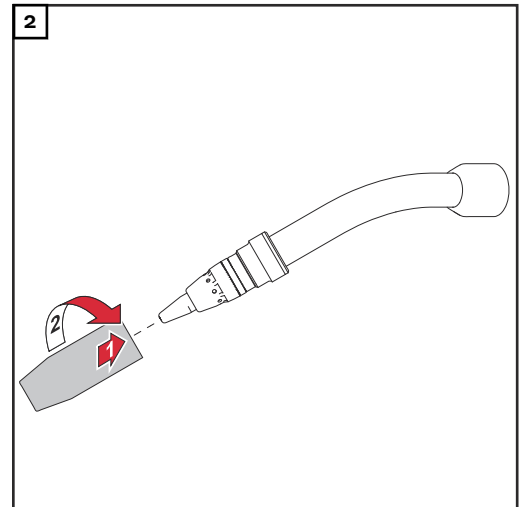
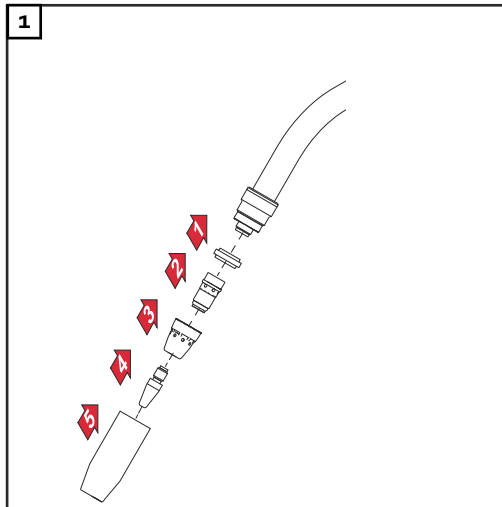

** Gasdüse bis auf Anschlag fest-
ziehen

MTG 400d K4,
MTW 500d K4 -
Verschleißteile
montieren

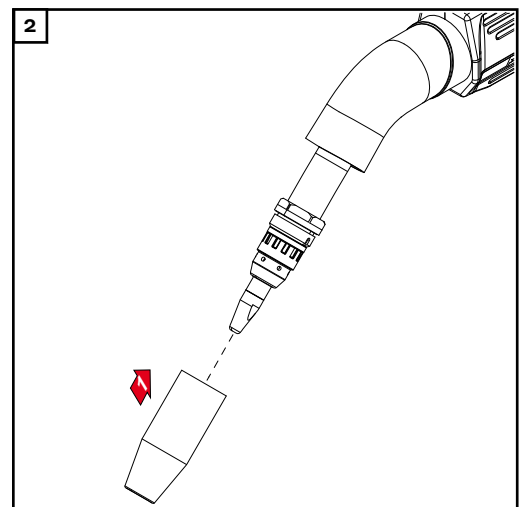
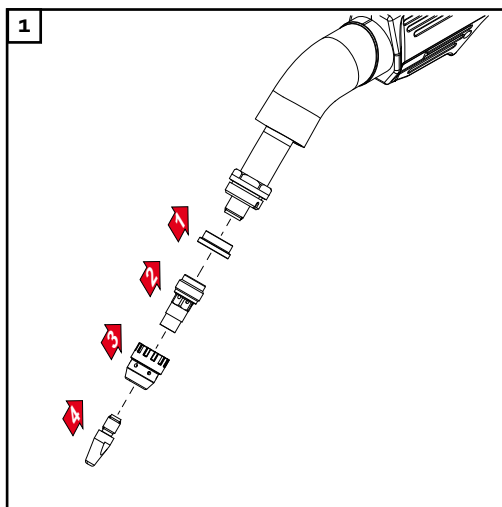

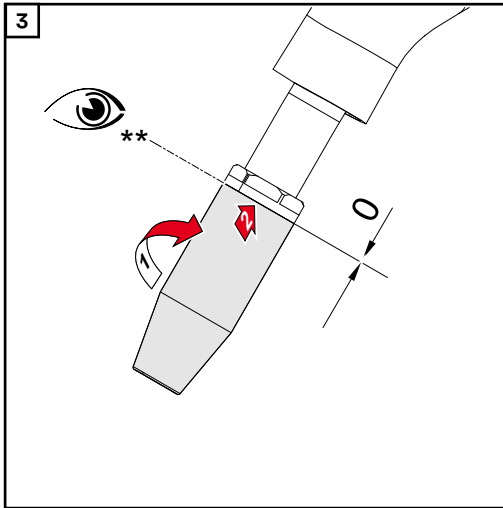

** Gasdüse bis auf Anschlag festziehen

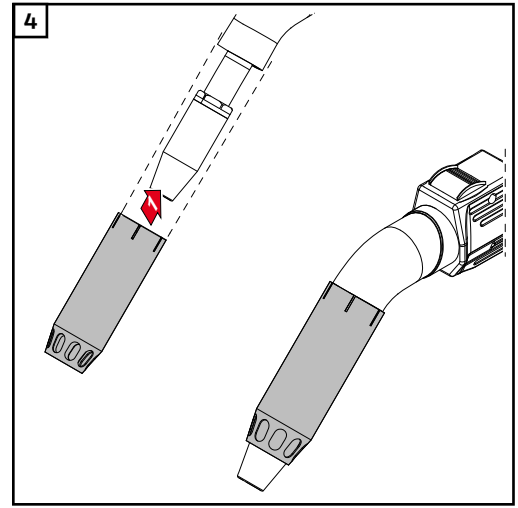

Absaugdüse aufstecken

ML-Brennerkörper am MHP-Schlauchpaket montieren

Multilock-Schweißbrenner zusammenbauen

HINWEIS!

Gefahr von Beschädigung des Schweißbrenners. Die Überwurfmutter des Brennerkörpers immer bis auf Anschlag festschrauben.

HINWEIS!

Bei wassergekühlten Schweißbrennern kann aufgrund der Bauweise des Schweißbrenners ein erhöhter Widerstand beim Festschrauben der Überwurfmutter auftreten. Dies ist normal. Die Überwurfmutter des Brennerkörpers immer bis auf Anschlag festschrauben.

HINWEIS!

Vor der Montage eines Brennerkörpers sicherstellen, dass die Kuppelstelle des Brennerkörpers und des Schlauchpaketes unbeschädigt und sauber ist.

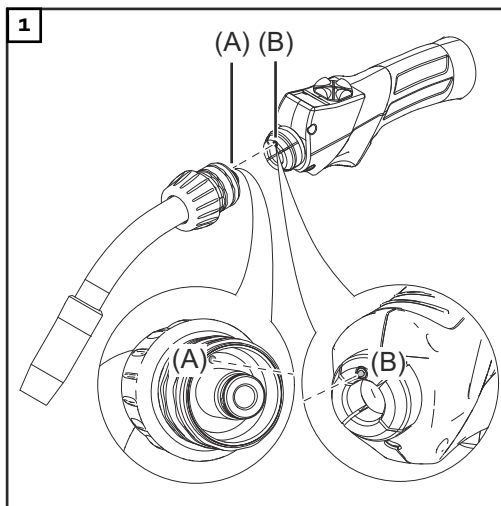

HINWEIS!

Wenn der Pass-Stift (A) des Schlauchpaketes in die Passbohrung (B) des Brennerkörpers greift, befindet sich der Brennerkörper in der 0°-Stellung.

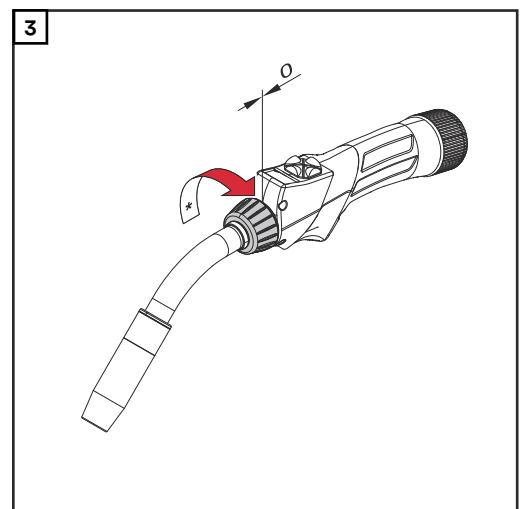
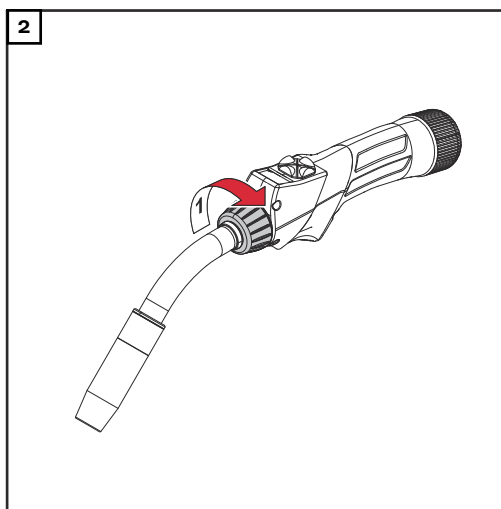

* Sicherstellen, dass die Überwurfmutter bis auf Anschlag festgeschraubt ist.

Draht-Führungsseelen montieren

Spann-Nippel überprüfen

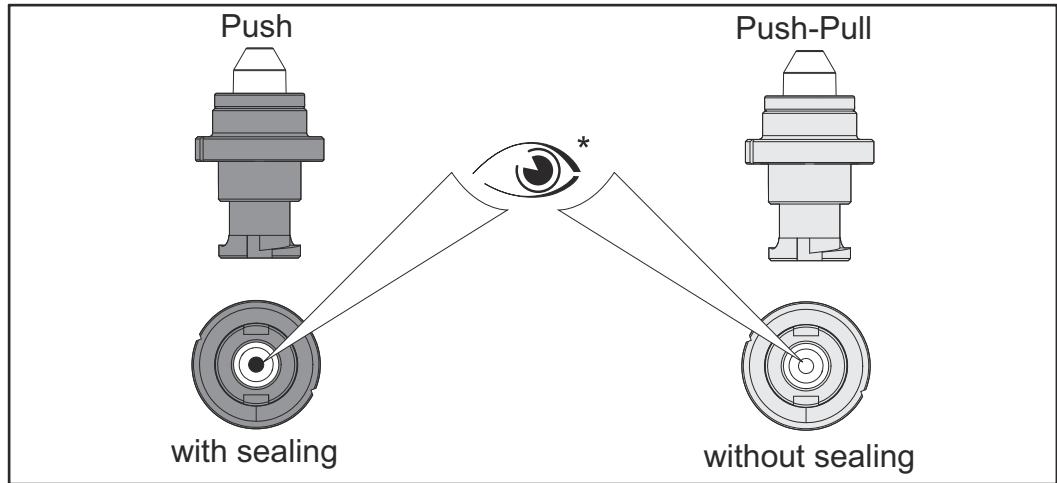

- * Vor Inbetriebnahme und bei jedem Wechsel der Drahtführungsseele den Spann-Nippel kontrollieren. Dazu eine Sichtkontrolle durchführen:
- links: Messing-Spann-Nippel mit Dichtscheibe. Durch die Dichtscheibe kann man nicht hindurchsehen.
 - rechts: silberner Spann-Nippel mit sichtbarer Durchführung

HINWEIS!

Falscher oder defekter Spann-Nippel bei Push-Anwendungen

Gasverlust und schlechte Schweiß Eigenschaften sind die Folge

- ▶ Messing-Spann-Nippel verwenden, um Gasverlust zu minimieren
- ▶ kontrollieren, ob die Dichtscheibe intakt ist

HINWEIS!

Falscher Spann-Nippel bei Push-Pull-Anwendungen

Drahtwickler und erhöhter Abrieb in der Draht-Führungsseele bei Verwendung eines Spann-Nippels mit Dichtscheibe

- ▶ silbernen Spann-Nippel verwenden, um Drahtführung zu erleichtern

Draht-Führungsseele aus Stahl montieren

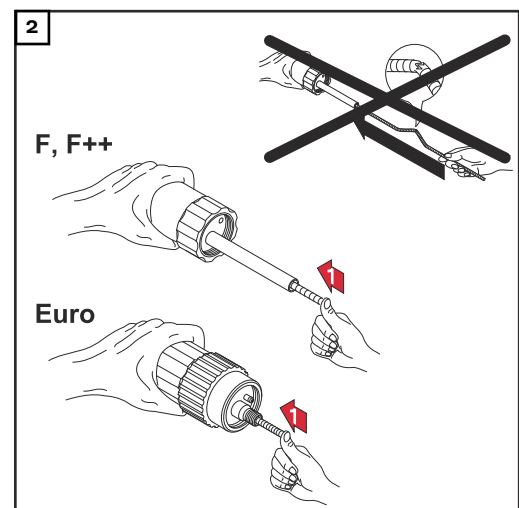
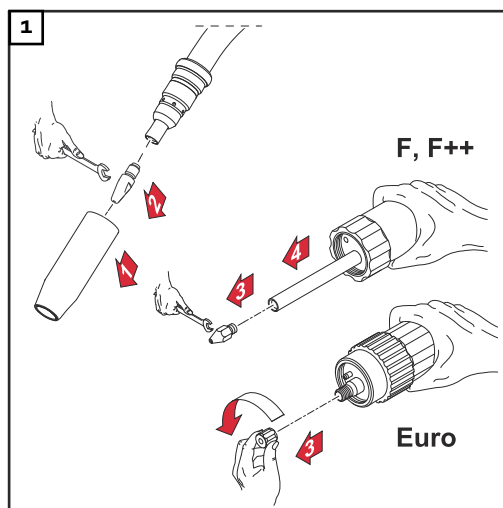

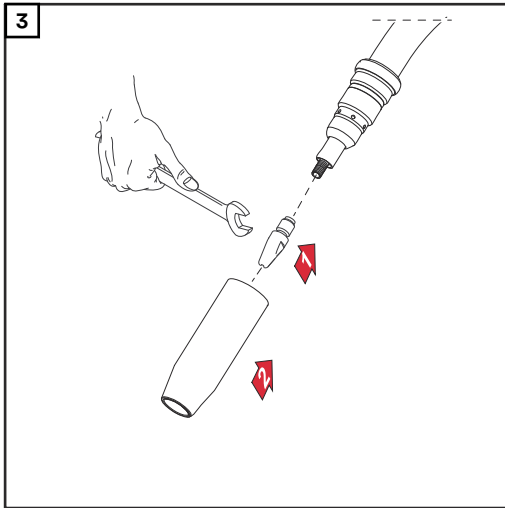

F++, F:

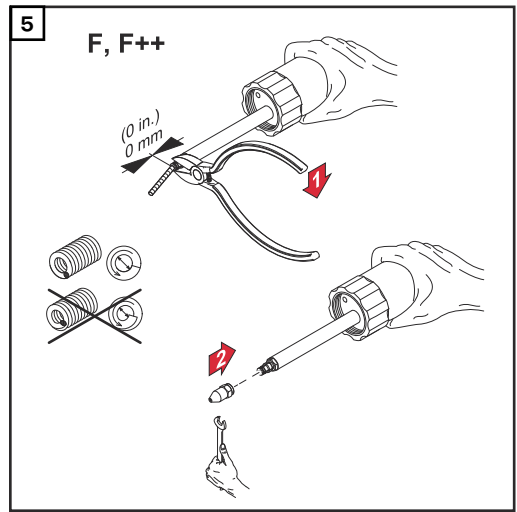
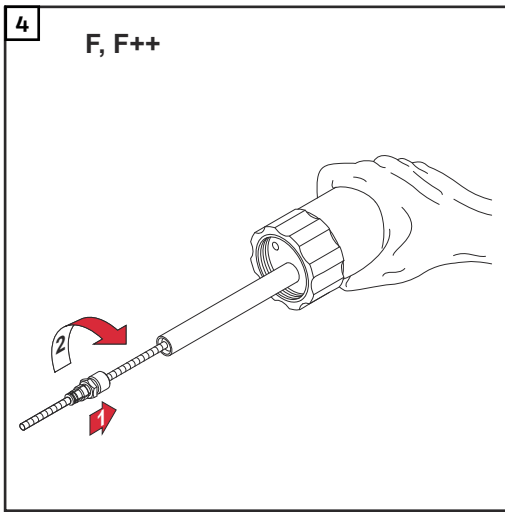

Euro:

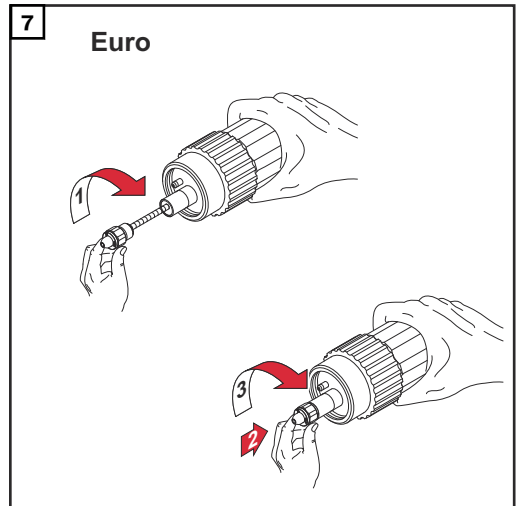
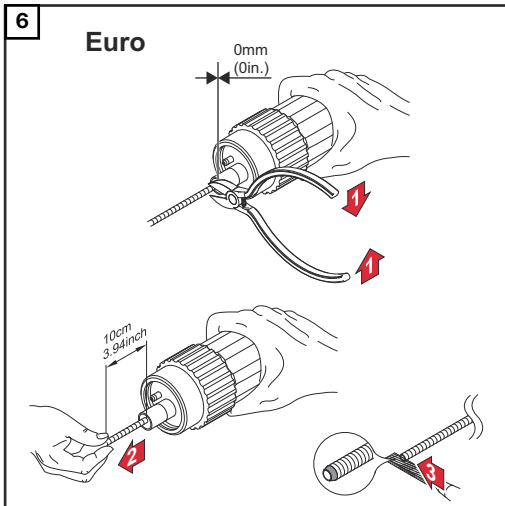

**Draht-Führungs-
seele aus Kunst-
stoff montieren
(F, F++)**

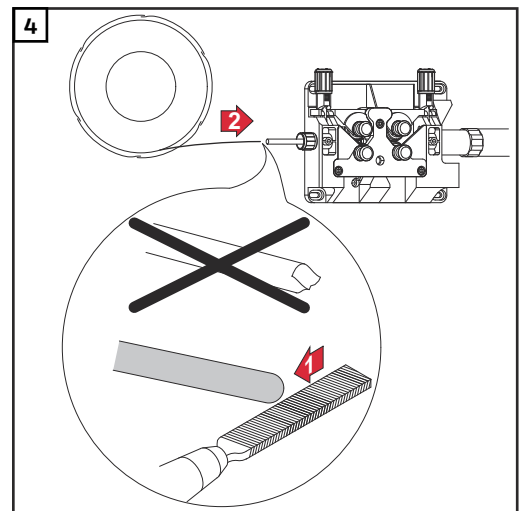
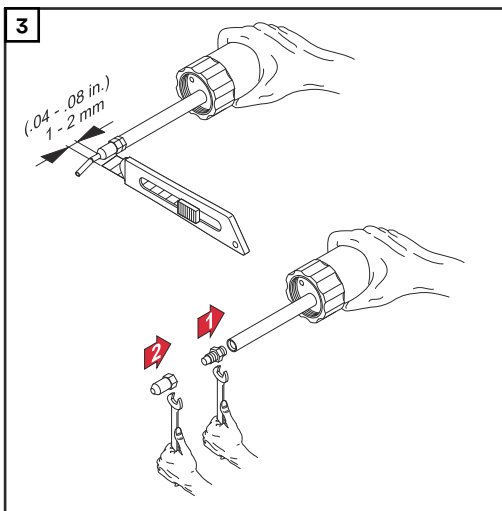
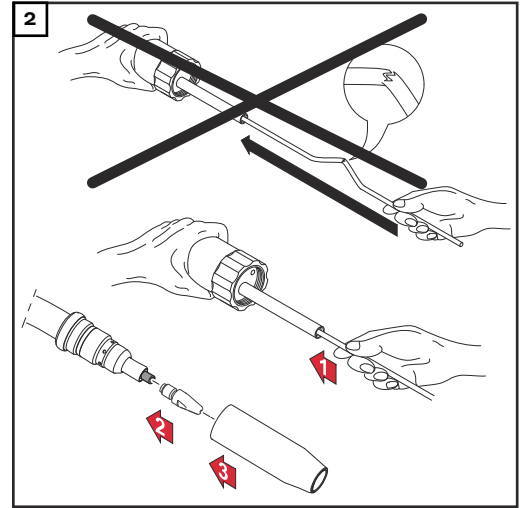
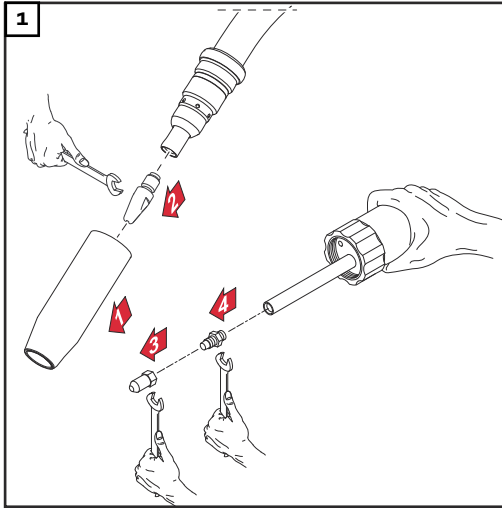

**Kunststoff-Seele montieren
(Fronius-Anschluss mit
Draht-
Führungsdüse)**

HINWEIS!

Vor dem Einfädeln der Drahtelektrode, Drahtelektroden-Ende abrunden.

Gilt für Teflonseelen, Kombiseelen und Graphitseelen

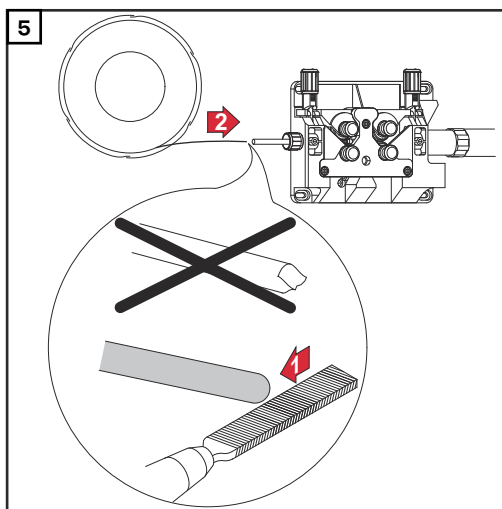
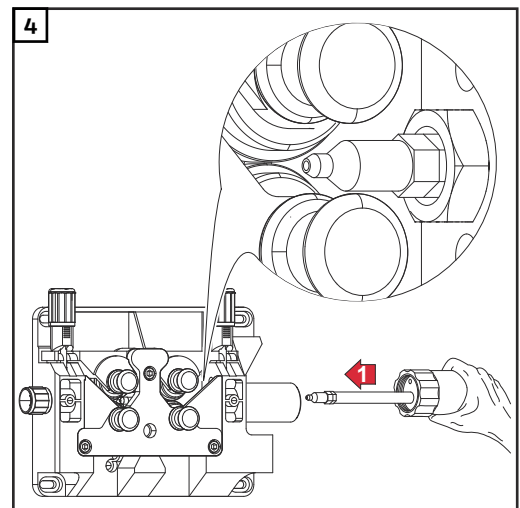
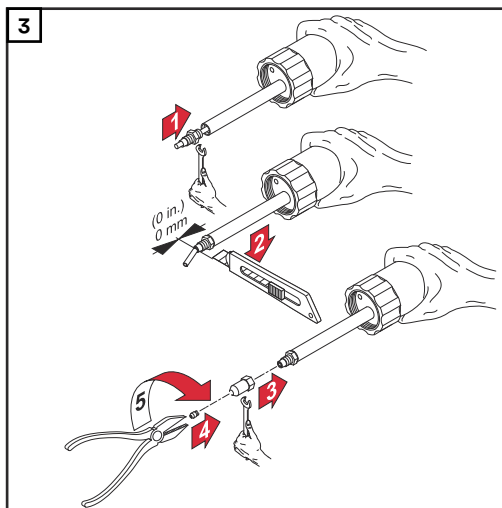
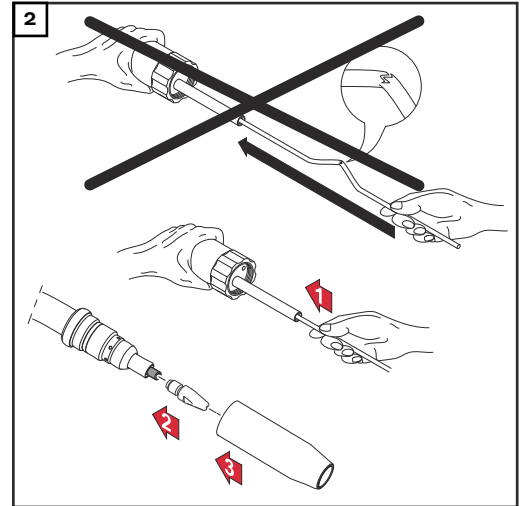
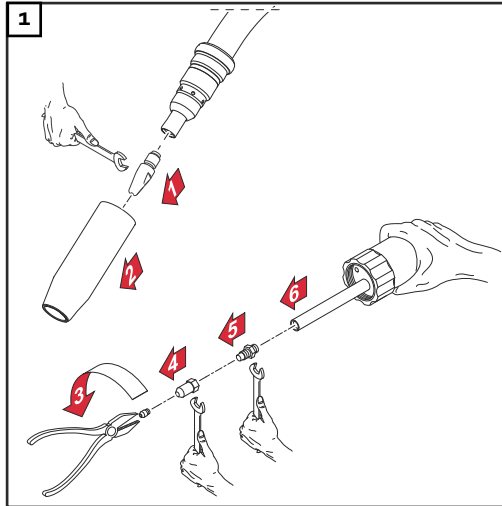

**Draht-Führungs-
seele aus Kunst-
stoff montieren
(Euro)**

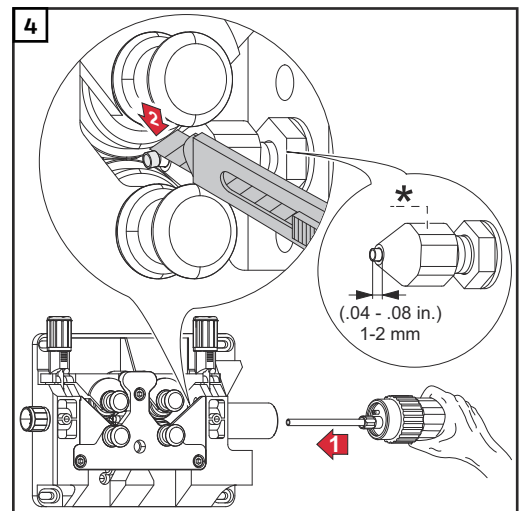
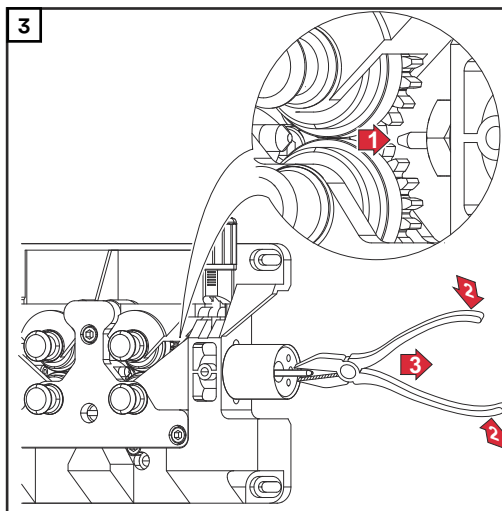
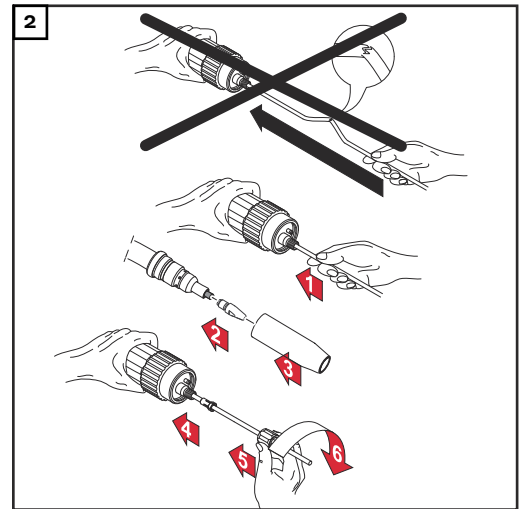
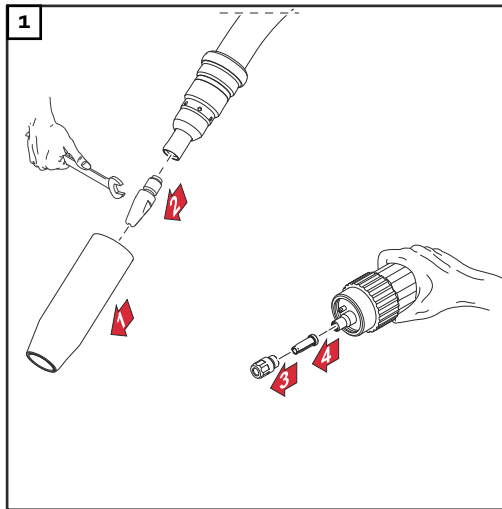

* Option Einlaufdüse (42,0001,5421)

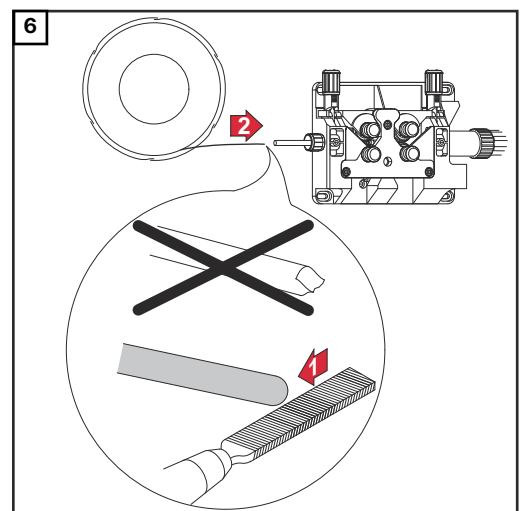
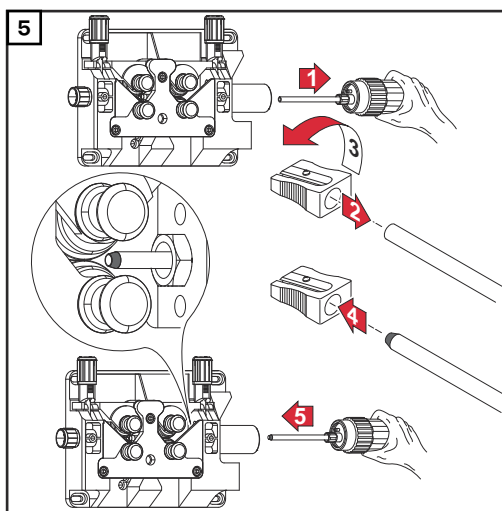

Inbetriebnahme

Schweißbrenner anschließen

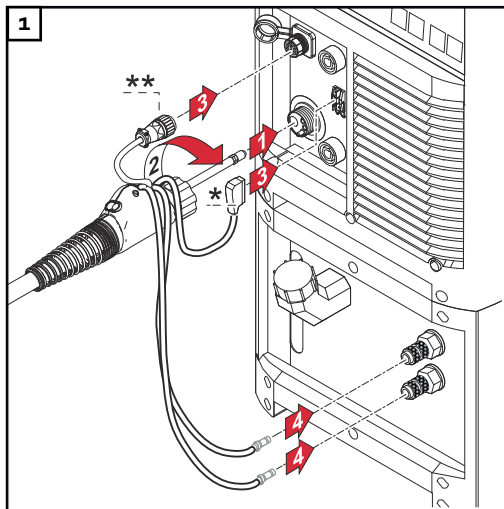

- * Stecker LocalNet
(Schweißbrenner Standard oder Up/Down)
- ** Stecker JobMaster
(Schweißbrenner JobMaster)

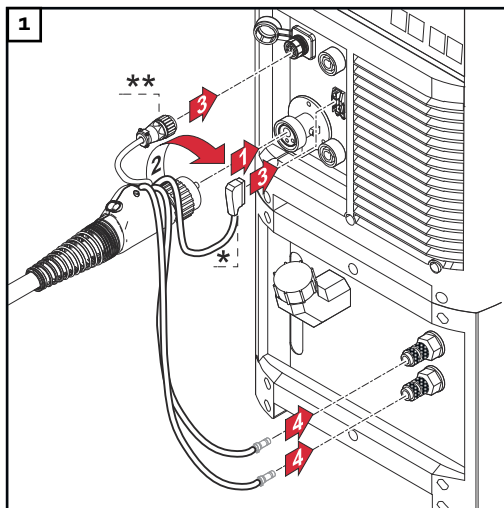

- * Stecker LocalNet
(Schweißbrenner Standard oder Up/Down)
- ** Stecker JobMaster
(Schweißbrenner JobMaster)

Absaugung anschließen

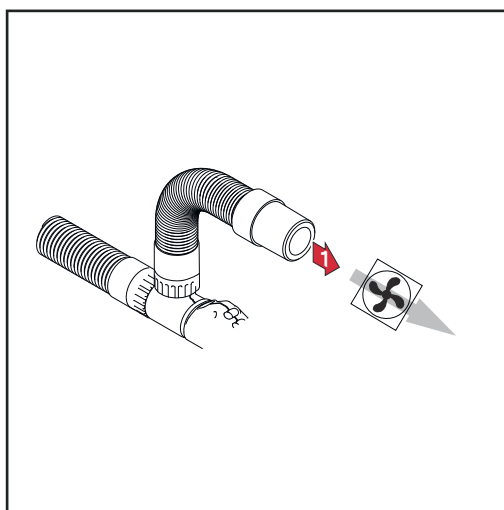

- 1 Schlauch für die Absaugung entsprechend den Richtwerten für Absauggeräte am Absauggerät anschließen

**Brennerkörper
des Multilock-
Schweißbren-
ners verdrehen**

⚠ VORSICHT!

Verbrennungsgefahr durch heißes Kühlmittel und heißen Brennerkörper.

- ▶ Vor Beginn der Arbeiten, das Kühlmittel und den Brennerkörper auf Zimmertemperatur (+25 °C, +77 °F) abkühlen lassen.

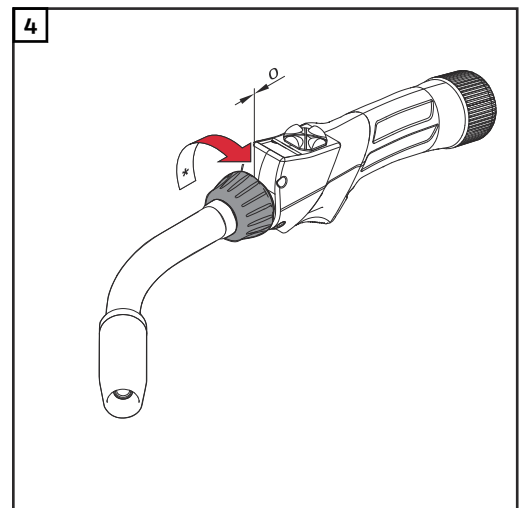
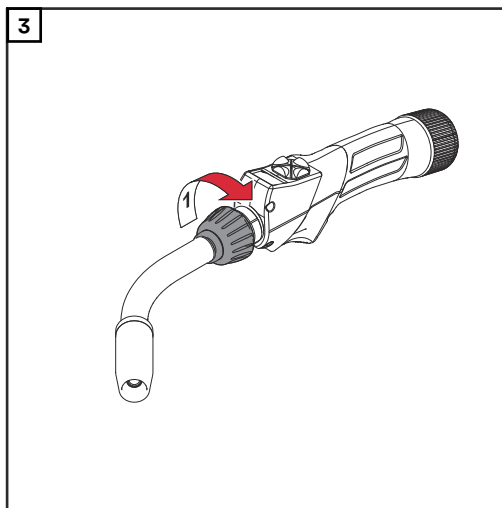
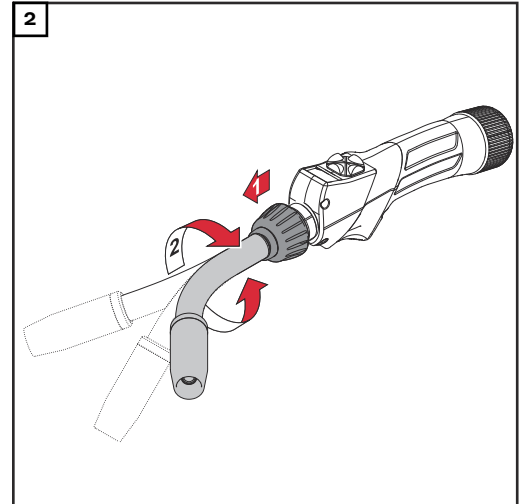
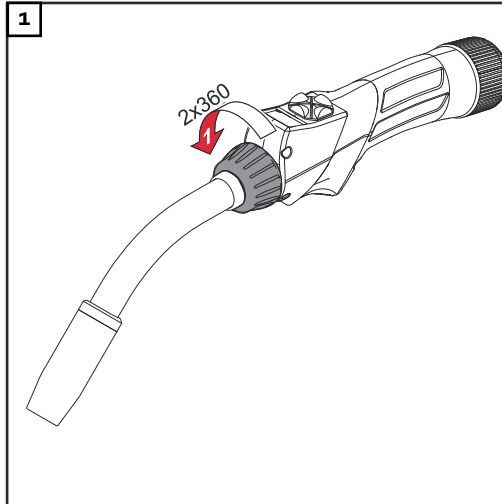

- * Sicherstellen, dass die Überwurfmutter bis auf Anschlag festgeschraubt ist.

Brennerkörper des Multilock- Schweißbren- ners wechseln

⚠ VORSICHT!

Verbrennungsgefahr durch heißes Kühlmittel und heißen Brennerkörper.

Schwere Verbrühungen können die Folge sein.

- ▶ Vor Beginn der Arbeiten, das Kühlmittel und den Brennerkörper auf Zimmertemperatur (+25 °C, +77 °F) abkühlen lassen.

HINWEIS!

Im Brennerkörper befindet sich immer ein Rest an Kühlmittel.

Brennerkörper nur demontieren, wenn die Gasdüse nach unten zeigt.

HINWEIS!

Vor der Montage eines Brennerkörpers sicherstellen, dass die Kuppelstelle des Brennerkörpers und des Schlauchpaketes unbeschädigt und sauber ist.

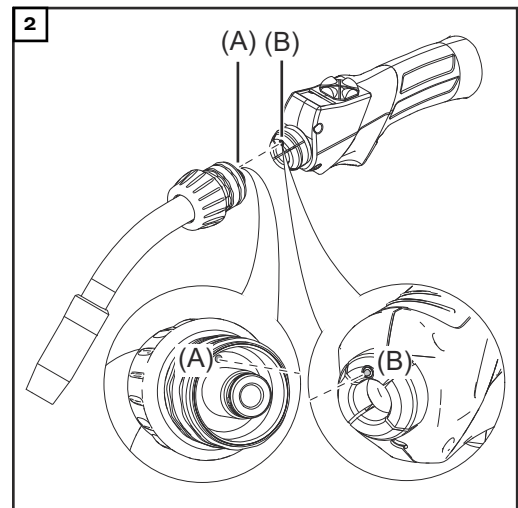
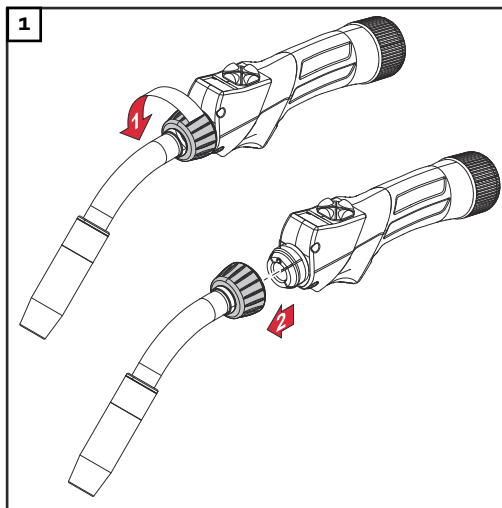

HINWEIS!

Wenn der Pass-Stift (A) des Schlauchpaketes in die Passbohrung (B) des Brennerkörpers greift, befindet sich der Brennerkörper in der 0°-Stellung.

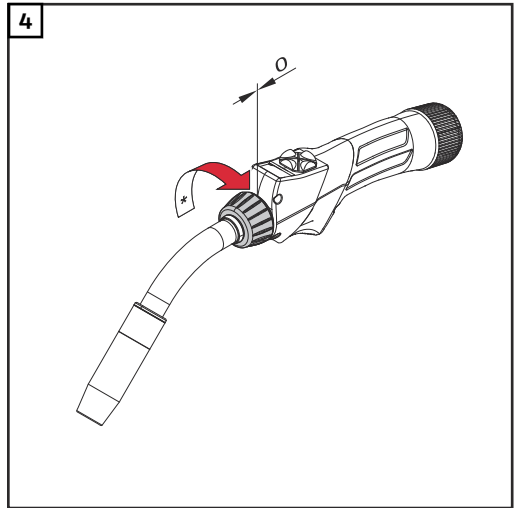
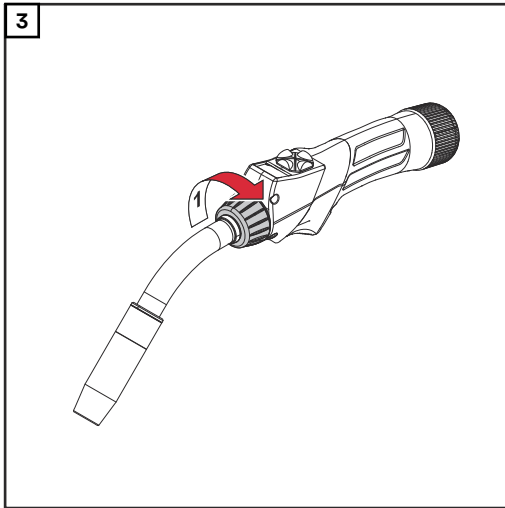

* Sicherstellen, dass die Überwurfmutter bis auf Anschlag festgeschraubt ist.

Prisma-Halterung für Maschinen-Schweißbrenner

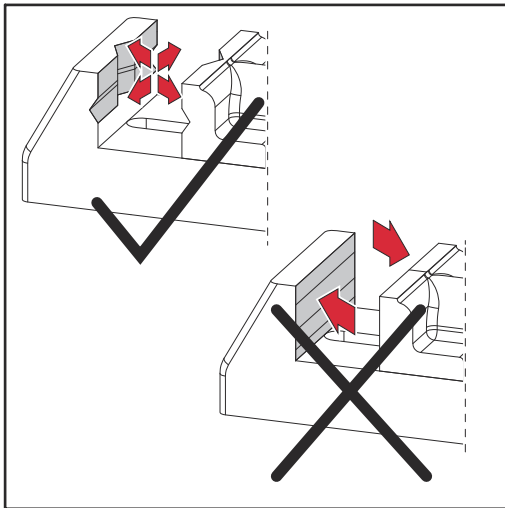

Den Maschinen-Schweißbrenner zur Bearbeitung nur in eine geeignete Prisma-Halterung einspannen!

Pflege und Wartung

Allgemeines

Regelmäßige und vorbeugende Wartung des Schweißbrenners sind wesentliche Faktoren für einen störungsfreien Betrieb. Der Schweißbrenner ist hohen Temperaturen und starker Verunreinigung ausgesetzt. Daher benötigt der Schweißbrenner eine häufigere Wartung als andere Komponenten des Schweißsystems.

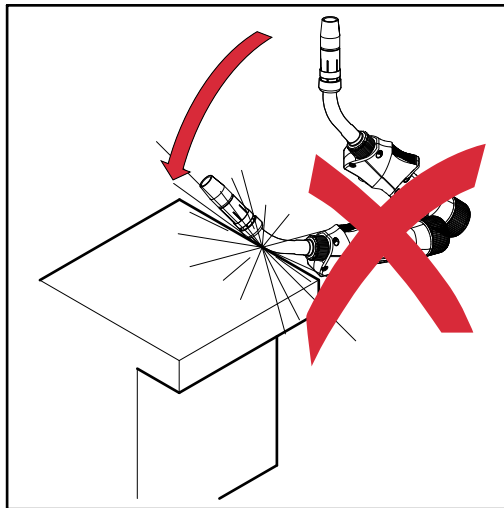

VORSICHT!

Beschädigungsgefahr durch unsachgemäßen Umgang mit dem Schweißbrenner.

Schwere Sachschäden können die Folge sein.

- ▶ Den Schweißbrenner nicht auf harte Gegenstände schlagen.
- ▶ Riefen und Kratzer im Kontaktrohr vermeiden.
- ▶ Den Brennerkörper keinesfalls biegen.

Erkennen von defekten Verschleißteilen

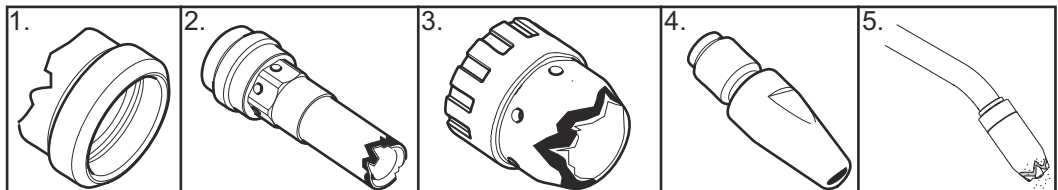

1. Isolierteile
 - abgebrannte Außenkanten, Einkerbungen
2. Düsenstöcke
 - abgebrannte Außenkanten, Einkerbungen
 - stark mit Schweißspritzern behaftet
3. Spritzerschutz
 - abgebrannte Außenkanten, Einkerbungen
4. Kontaktrohre
 - ausgeschliffene (ovale) Draht Eintritts- und Drahtaustritts-Bohrungen
 - stark mit Schweißspritzern behaftet
 - Einbrand an der Kontaktrohr-Spitze
5. Gasdüsen
 - stark mit Schweißspritzern behaftet
 - abgebrannte Außenkanten
 - Einkerbungen

Wartung bei jeder Inbetriebnahme

- Verschleißteile kontrollieren
- defekte Verschleißteile austauschen
- Gasdüse von Schweißspritzern befreien

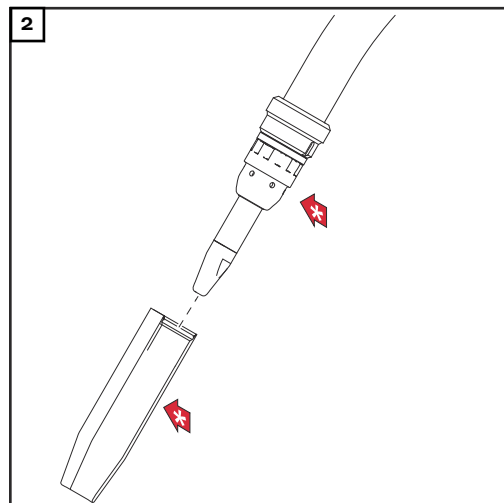
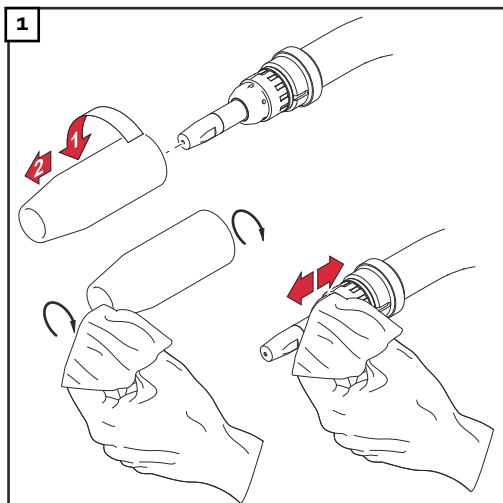

- * Gasdüse, Spritzerschutz und Isolationen auf Beschädigung prüfen und beschädigte Komponenten austauschen.
- Zusätzlich bei jeder Inbetriebnahme, bei wassergekühlten Schweißbrennern:
 - sicherstellen, dass alle Kühlmittel-Anschlüsse dicht sind
 - sicherstellen, dass ein ordnungsgemäßer Kühlmittel-Rückfluss gegeben ist

Wartung bei jedem Austausch der Draht- / Korbspule

- Draht-Förderschlauch mit reduzierter Druckluft reinigen
- Empfohlen: Draht-Führungsseele austauschen, vor dem erneuten Einbau der Draht-Führungsseele die Verschleißteile reinigen

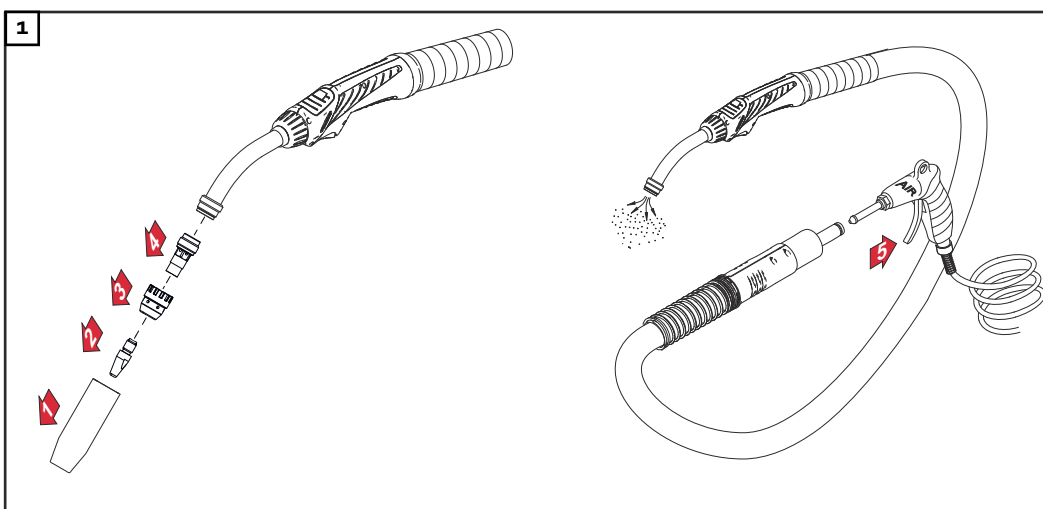

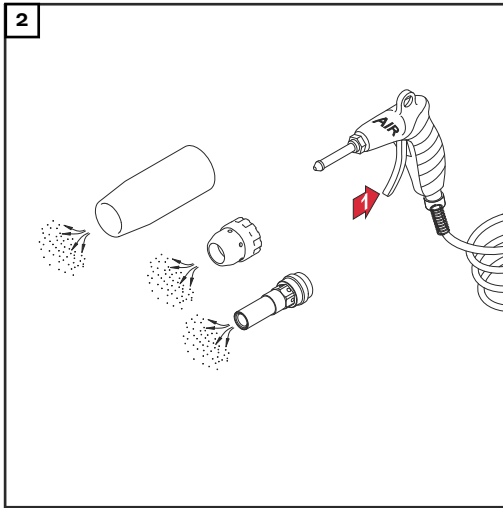

Fehlerdiagnose, Fehlerbehebung

Kein Schweißstrom

Netzschalter der Stromquelle eingeschaltet, Anzeigen an der Stromquelle leuchten, Schutzgas vorhanden

Ursache: Masseanschluss falsch

Behebung: Masseanschluss ordnungsgemäß herstellen

Ursache: Stromkabel im Schweißbrenner unterbrochen

Behebung: Schweißbrenner austauschen

Keine Funktion nach Drücken der Brenntaste

Netzschalter der Stromquelle eingeschaltet, Anzeigen an der Stromquelle leuchten

Ursache: FSC ('Fronius System Connector' - Zentralanschluss) nicht bis auf Anschlag eingesteckt

Behebung: FSC bis auf Anschlag einstecken

Ursache: Schweißbrenner oder Schweißbrenner-Steuerleitung defekt

Behebung: Schweißbrenner austauschen

Ursache: Verbindungs-Schlauchpaket nicht ordnungsgemäß angeschlossen oder defekt

Behebung: Verbindungs-Schlauchpaket ordnungsgemäß anschließen
Defektes Verbindungs-Schlauchpaket austauschen

Ursache: Stromquelle defekt

Behebung: Service-Dienst verständigen

Kein Schutzgas

alle anderen Funktionen vorhanden

Ursache: Gasflasche leer

Behebung: Gasflasche wechseln

Ursache: Gas-Druckminderer defekt

Behebung: Gas-Druckminderer austauschen

Ursache: Gasschlauch nicht montiert, geknickt oder schadhaft

Behebung: Gasschlauch montieren, gerade auslegen. Defekten Gasschlauch austauschen

Ursache: Schweißbrenner defekt

Behebung: Schweißbrenner austauschen

Ursache: Gas-Magnetventil defekt

Behebung: Service-Dienst verständigen (Gas-Magnetventil austauschen lassen)

Schlechte Schweißeigenschaften

Ursache: Falsche Schweißparameter

Behebung: Einstellungen korrigieren

Ursache: Masseverbindung schlecht

Behebung: Guten Kontakt zum Werkstück herstellen

Ursache: Kein oder zu wenig Schutzgas

Behebung: Druckminderer, Gasschlauch, Gas-Magnetventil und Schweißbrenner-Gasanschluss überprüfen. Bei gasgekühlten Schweißbrennern Gasabdichtung überprüfen, geeignete Draht-Führungsseele verwenden

Ursache: Schweißbrenner undicht

Behebung: Schweißbrenner austauschen

Ursache: Zu großes oder ausgeschliffenes Kontaktrohr

Behebung: Kontaktrohr wechseln

Ursache: Falsche Drahtlegierung oder falscher Drahtdurchmesser

Behebung: Eingelegte Draht- /Korbspule überprüfen

Ursache: Falsche Drahtlegierung oder falscher Drahtdurchmesser

Behebung: Verschweißbarkeit des Grund-Werkstoffes prüfen

Ursache: Schutzgas für Drahtlegierung nicht geeignet

Behebung: Korrektes Schutzgas verwenden

Ursache: Ungünstige Schweißbedingungen: Schutzgas verunreinigt (Feuchtigkeit, Luft), mangelhafte Gas-Abschirmung (Schmelzbad „kocht“, Zugluft), Verunreinigungen im Werkstück (Rost, Lack, Fett)

Behebung: Schweißbedingungen optimieren

Ursache: Schutzgas geht bei Spann-Nippel aus

Behebung: richtigen Spann-Nippel verwenden

Ursache: Dichtscheibe Spann-Nippel defekt, Schutzgas geht bei Spann-Nippel aus

Behebung: Spann-Nippel austauschen, um Gasdichtheit zu gewährleisten

Ursache: Schweißspritzer in der Gasdüse

Behebung: Schweißspritzer entfernen

Ursache: Turbulenzen auf Grund zu hoher Schutzgas-Menge

Behebung: Schutzgas-Menge reduzieren, empfohlen:
 $\text{Schutzgas-Menge (l/min)} = \text{Drahtdurchmesser (mm)} \times 10$
(beispielsweise 16 l/min für 1,6 mm Drahtelektrode)

Ursache: Zu großer Abstand zwischen Schweißbrenner und Werkstück

Behebung: Abstand zwischen Schweißbrenner und Werkstück reduzieren (ca. 10 - 15 mm / 0.39 - 0.59 in.)

Ursache: Zu großer Anstellwinkel des Schweißbrenners

Behebung: Anstellwinkel des Schweißbrenners reduzieren

Ursache: Draht-Förderkomponenten passen nicht zum Durchmesser der Drahtelektrode / dem Werkstoff der Drahtelektrode

Behebung: Richtige Draht-Förderkomponenten einsetzen

Schlechte Drahtförderung

Ursache: Je nach System, Bremse im Drahtvorschub oder in der Stromquelle zu fest eingestellt

Behebung: Bremse lockerer einstellen

Ursache: Bohrung des Kontaktrohres verlegt

Behebung: Kontaktrohr austauschen

Ursache: Draht-Führungsseele oder Draht-Führungseinsatz defekt

Behebung: Draht-Führungsseele oder Draht-Führungseinsatz auf Knicke, Verschmutzung, etc. prüfen
Defekte Draht-Führungsseele, defekten Draht-Führungseinsatz austauschen

Ursache: Vorschubrollen für verwendete Drahtelektrode nicht geeignet

Behebung: Passende Vorschubrollen verwenden

Ursache: Falscher Anpressdruck der Vorschubrollen

Behebung: Anpressdruck optimieren

Ursache: Vorschubrollen verunreinigt oder beschädigt

Behebung: Vorschubrollen reinigen oder austauschen

Ursache: Draht-Führungsseele verlegt oder geknickt

Behebung: Draht-Führungsseele austauschen

Ursache: Draht-Führungsseele nach dem Ablängen zu kurz

Behebung: Draht-Führungsseele austauschen und neue Draht-Führungsseele auf korrekte Länge kürzen

Ursache: Abrieb der Drahtelektrode infolge von zu starkem Anpressdruck an den Vorschubrollen

Behebung: Anpressdruck an den Vorschubrollen reduzieren

Ursache: Drahtelektrode verunreinigt oder angerostet

Behebung: Hochwertige Drahtelektrode ohne Verunreinigungen verwenden

Ursache: Bei Draht-Führungsseelen aus Stahl: unbeschichtete Draht-Führungsseele in Verwendung

Behebung: Beschichtete Draht-Führungsseele verwenden

Ursache: Draht Eintritts- und Draht Austritts-Bereich Spann-Nippel verformt (oval, ausgeschlagen), Schutzgas geht bei Spann-Nippel aus

Behebung: Spann-Nippel austauschen, um Gasdichtheit zu gewährleisten

Gasdüse wird sehr heiß

Ursache: Keine Wärmeableitung auf Grund zu losen Sitzes der Gasdüse

Behebung: Gasdüse bis auf Anschlag festschrauben

Schweißbrenner wird sehr heiß

Ursache: Nur bei Multilock-Schweißbrennern: Überwurfmutter des Brennerkörpers locker

Behebung: Überwurfmutter festziehen

Ursache: Schweißbrenner wurde über dem maximalen Schweißstrom betrieben

Behebung: Schweißleistung herabsetzen oder leistungsfähigeren Schweißbrenner verwenden

Ursache: Schweißbrenner zu schwach dimensioniert

Behebung: Einschaltdauer und Belastungsgrenzen beachten

Ursache: Nur bei wassergekühlten Anlagen: Kühlmittel-Durchfluss zu gering

Behebung: Kühlmittel-Stand, Kühlmittel-Durchflussmenge, Kühlmittel-Verschmutzung, Verlegung des Schlauchpaketes etc. überprüfen

Ursache: Spitze des Schweißbrenners zu nahe am Lichtbogen

Behebung: Stick-Out vergrößern

Kurze Lebensdauer des Kontaktrohres

Ursache: Falsche Vorschubrollen

Behebung: Korrekte Vorschubrollen verwenden

Ursache: Abrieb der Drahtelektrode infolge von zu starkem Anpressdruck an den Vorschubrollen

Behebung: Anpressdruck an den Vorschubrollen reduzieren

Ursache: Drahtelektrode verunreinigt / angerostet

Behebung: Hochwertige Drahtelektrode ohne Verunreinigungen verwenden

Ursache: Unbeschichtete Drahtelektrode

Behebung: Drahtelektrode mit geeigneter Beschichtung verwenden

Ursache: Falsche Dimension des Kontaktrohres

Behebung: Kontaktrohr korrekt dimensionieren

Ursache: Zu lange Einschaltdauer des Schweißbrenners

Behebung: Einschaltdauer herabsetzen oder leistungsfähigeren Schweißbrenner verwenden

Ursache: Kontaktrohr überhitzt. Keine Wärmeableitung auf Grund zu losen Sitzes des Kontaktrohres

Behebung: Kontaktrohr festziehen

HINWEIS!

Bei CrNi-Anwendungen kann auf Grund der Oberflächen-Beschaffenheit der CrNi-Drahtelektrode ein höherer Kontaktrohr-Verschleiß auftreten.

Fehlfunktion der Brennertaste

Ursache: Steckverbindungen zwischen Schweißbrenner und Stromquelle fehlerhaft

Behebung: Steckverbindungen ordnungsgemäß herstellen / Stromquelle oder Schweißbrenner zum Service

Ursache: Verunreinigungen zwischen Brennertaste und dem Gehäuse der Brennertaste

Behebung: Verunreinigungen entfernen

Ursache: Steuerleitung ist defekt

Behebung: Service-Dienst verständigen

Porosität der Schweißnaht

Ursache: Spritzerbildung in der Gasdüse, dadurch unzureichender Gasschutz der Schweißnaht

Behebung: Schweißspritzer entfernen

Ursache: Löcher im Gasschlauch oder ungenaue Anbindung des Gasschlauches

Behebung: Gasschlauch austauschen

Ursache: O-Ring am Zentralanschluss ist zerschnitten oder defekt

Behebung: O-Ring austauschen

Ursache: Feuchtigkeit / Kondensat in der Gasleitung

Behebung: Gasleitung trocknen

Ursache: Zu starke oder zu geringe Gasströmung

Behebung: Gasströmung korrigieren

Ursache: Ungenügende Gasmenge zu Schweißbeginn oder Schweißende

Behebung: Gas-Vorströmung und Gas-Nachströmung erhöhen

Ursache: Rostige oder schlechte Qualität der Drahtelektrode

Behebung: Hochwertige Drahtelektrode ohne Verunreinigungen verwenden

Ursache: Gilt für gasgekühlte Schweißbrenner: Gasaustritt bei nicht isolierten Draht-Führungsseelen

Behebung: Bei gasgekühlten Schweißbrennern nur isolierte Draht-Führungsseelen verwenden

Ursache: Zu viel Trennmittel aufgetragen

Behebung: Überschüssiges Trennmittel entfernen / weniger Trennmittel auftragen

Ursache: Zu starke Absaugung

Behebung: Absaugung reduzieren

Zu geringe Absaugung

Ursache: Löcher im Absaugschlauch

Behebung: Absaugschlauch erneuern

Ursache: Filter des Absauggerätes verlegt

Behebung: Filter des Absauggerätes erneuern

Ursache: Luftwege anderwärtig verstopft

Behebung: Verstopfungen beseitigen

Ursache: Zu geringe Absaugleistung des Absauggerätes;
falsche Konfiguration von OPT/i FumeEx

Behebung: Absauggerät mit höherer Absaugleistung verwenden;
Absaugleistung erhöhen

Technische Daten

Allgemeines

Spannungsbemessung (V-Peak):

- für handgeführte Schweißbrenner: 113 V
- für maschinell geführte Schweißbrenner: 141 V

Technische Daten Brenntaste:

- $U_{max} = 5 \text{ V}$
- $I_{max} = 10 \text{ mA}$

Der Betrieb der Brenntaste ist nur im Rahmen der technischen Daten erlaubt.

Das Produkt entspricht den Anforderungen laut Norm IEC 60974-7 / - 10 CI. A.

Schweißbrenner gasgekühlt - MTG 250d - 500d

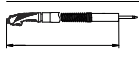
	MTG 250d	MTG 320d	MTG 400d	MTG 500d
I (Amp.) 10 min/40° C CO ²	40% ED* 250 60% ED* 200 100% ED* 170	40% ED* 320 60% ED* 260 100% ED* 210	40% ED* 400 60% ED* 320 100% ED* 260	40% ED* 500 60% ED* 400 100% ED* 320
I (Amp.) 10 min/40° C M21	40% ED* 200 60% ED 160 100% ED 120	40% ED* 260 60% ED* 210 100% ED* 160	40% ED* 320 60% ED* 260 100% ED* 210	40% ED* 400 60% ED* 320 100% ED* 260
 [mm (in.)]	0,8-1,2 (.032-.047)	0,8-1,6 (.032-.063)	1,0-1,6 (.039-.063)	1,0-1,6 (.039-.063)
 [m (ft.)]	3,5 / 4,5 (12 / 15)	3,5 / 4,5 (12 / 15)	3,5 / 4,5 (12 / 15)	3,5 / 4,5 (12 / 15)

* ED = Einschaltdauer

Brennerkörper gasgekühlt - MTB 250i, 320i, 330i, 400i, 550i G ML

	MTB 250i G ML	MTB 320i G ML	MTB 330i G ML
I (Ampère) 10 min/40° C M21+C1 (EN 439)	40 % ED* 250 60 % ED* 200 100 % ED* 170	40 % ED* 320 60 % ED* 260 100 % ED* 210	40 % ED* 330 60 % ED* 270 100 % ED* 220
 [mm (in.)]	0,8-1,2 (.032-.047)	0,8-1,6 (.032-.063)	0,8-1,6 (.032-.063)



* ED = Einschaltdauer

	MTB 400i G ML	MTB 550i G ML
I (Ampère) 10 min/40° C C1 (EN 439)	-	30 % ED* 550

	MTB 400i G ML	MTB 550i G ML
I (Ampère) 10 min/40° C M21 (EN 439)	-	30 % ED* 520
I (Ampère) 10 min/40° C M21+C1 (EN 439)	40 % ED* 400 60 % ED* 320 100 % ED* 260	- 60 % ED* 420 100 % ED* 360
 [mm (in.)]	0,8-1,6 (.032-.063)	0,8-1,6 (.032-.063)



* ED = Einschaltdauer

**Schlauchpaket
gasgekühlt -
MHP 400d G ML**

	MHP 400d G ML
I (Ampère) 10 min/40° C CO ²	40 % ED* 400 60 % ED* 320 100 % ED* 260
I (Ampère) 10 min/40° C M21	40 % ED* 320 60 % ED* 260 100 % ED* 210
 [mm (in.)]	0,8-1,6 (.032-.063)
 [m (ft.)]	3,35 / 4,35 (11 / 14)

* ED = Einschaltdauer





**Schlauchpaket
gasgekühlt -
MHP 500d G ML M**

	MHP 500d G ML M
I (Amp.) 10 min/40° C CO ²	40 % ED* 500 60 % ED* 400 100 % ED* 320
I (Amp.) 10 min/40° C M21	40 % ED* 400 60 % ED* 320 100 % ED* 260
 [mm (in.)]	0,8-1,6 (.032-.063)
 [m (ft.)]	1,35 / 2,35 / 3,35 (4.4 / 7.7 / 14)

* ED = Einschaltdauer

**Schweißbrenner
wassergekühlt -
MTW 250d -
700d**

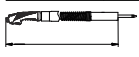

	MTW 250d	MTW 400d	MTW 500d	MTW 700d
I (Ampère) 10 min/40° C CO ²	100% ED* 250	100% ED* 400	100% ED* 500	100% ED* 700

	MTW 250d	MTW 400d	MTW 500d	MTW 700d
I (Ampère) 10 min/40° C M21	100% ED* 200	100% ED* 320	100% ED* 400	100% ED* 560
 [mm (in.)]	0,8-1,2 (.032-.047)	0,8-1,6 (.032-.063)	0,8-1,6 (.032-.063)	0,8-1,6 (.032-.063)
Q _{min}  [l/min (gal./min)]	1 (.26)	1 (.26)	1 (.26)	1 (.26)
P _{min}  [W]**	500 (3,5 m) 600 (4,5 m)	800 (3,5 m) 950 (4,5 m)	1400 (3,5 m) 1700 (4,5 m)	1800 (3,5 m) 2200 (4,5 m)
P _{min}  [bar (psi.)]	3 (43)	3 (43)	3 (43)	3 (43)
P _{max}  [bar (psi.)]	5 (72)	5 (72)	5 (72)	5 (72)
 [m (ft.)]	3,5 / 4,5 (12 / 15)	3,5 / 4,5 (12 / 15)	3,5 / 4,5 (12 / 15)	3,5 / 4,5 (12 / 15)



* ED = Einschaltdauer

** Geringste Kühlleistung laut Norm IEC 60974-2

**Brennerkörper
wassergekühlt -
MTB 250i, 330i,
400i, 500i, 700i
W ML**







	MTB 250i W ML	MTB 330i W ML	MTB 400i W ML	MTB 500i W ML
I (Ampère) 10 min/40° C M21+C1 (EN 439)	100 % ED* 250	100 % ED* 330	100 % ED* 400	100 % ED* 500
 [mm (in.)]	0,8-1,2 (.032-.047)	0,8-1,6 (.032-.063)	0,8-1,6 (.032-.063)	1,0-1,6 (.039-.063)
Q _{min}  [l/min (gal./min)]	1 (.26)	1 (.26)	1 (.26)	1 (.26)

* ED = Einschaltdauer

	MTB 700i W ML
I (Ampère) 10 min/40° C M21+C1 (EN 439)	100 % ED* 700
 [mm (in.)]	1,0-1,6 (.039-.063)
Q _{min}  [l/min (gal./min)]	1 (.26)

* ED = Einschaltdauer





**Schlauchpaket
wassergekühlt -
MHP 500d, 700d
W ML**

	MHP 500d W ML	MHP 700d W ML
I (Ampère) 10 min/40° C CO ²	100 % ED* 500	100 % ED* 700
I (Ampère) 10 min/40° C M21	100 % ED* 400	100 % ED* 560
 [mm (in.)]	0,8-1,6 (.032-.063)	0,8-1,6 (.032-.063)
 [m (ft.)]	3,35 / 4,35 (11 / 14)	3,35 / 4,35 (11 / 14)
P _{min}  [W]**	1400 / 1700	1800 / 2200
Q _{min}  [l/min (gal./ min.)]	1 (.26)	1 (.26)
P _{min}  [bar (psi.)]	3 (43)	3 (43)
P _{max}  [bar (psi.)]	5 (72)	5 (72)

* ED = Einschaltdauer

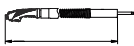
** Geringste Kühlleistung laut Norm IEC 60974-2



**Schlauchpaket
wassergekühlt -
MHP 700d W ML M**

	MHP 700d W ML M
I (Ampère) 10 min/40° C CO ²	100 % ED* 700
I (Ampère) 10 min/40° C M21	100 % ED* 560
 [mm (in.)]	0,8-1,6 (.032-.063)
 [m (ft.)]	1,35 / 2,35 / 3,35 (4.4 / 7.7 / 14)
P _{min}  [W]**	1100 / 1450 / 1800
Q _{min}  [l/min (gal./ min.)]	1 (.26)
P _{min}  [bar (psi.)]	3 (43)
P _{max}  [bar (psi.)]	5 (72)

* ED = Einschaltdauer

** Geringste Kühlleistung laut Norm IEC 60974-2

MTG 400d K4



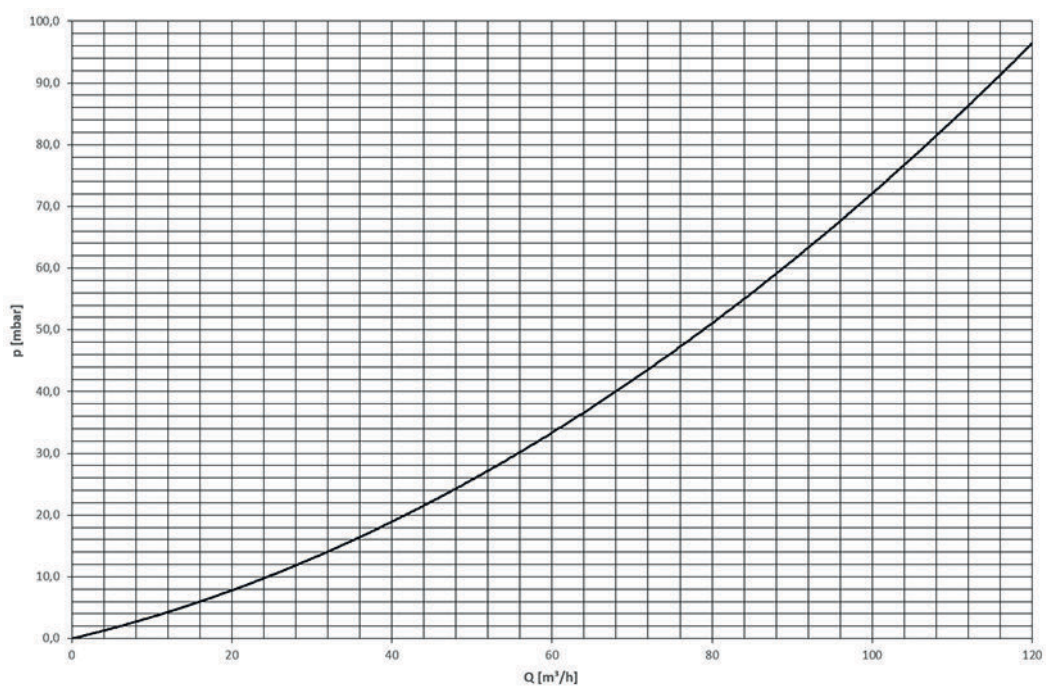

	MTG 400d K4
I (Ampère) 10 min/40° C CO ₂ / mixed	40 % ED* 400 60 % ED* 320 100 % ED* 260
 [mm (in.)]	0,8-1,6 (.032-.063)
 [m (ft.)]	4,5 (15)

* ED = Einschaltdauer

Absaug-Kennlinie MTG 400d K4

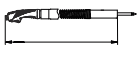

MTW 500d K4

MTW 500d K4		MTW 500d K4
I (Ampère) 10 min/40° C CO ₂ / mixed		100 % ED* 500
 [mm (in.)]		0,8-1,6 (.032-.063)
 [m (ft.)]		4,5 (15)
P _{max}  [W]**		1700
Q _{min}  [l/min (gal./min)]		1 (26)
P _{min}  [bar (psi.)]		3 (43)
P _{max}  [bar (psi.)]		5 (72)

* ED = Einschaltdauer

** Geringste Kühlleistung laut Norm IEC 60974-2

Absaug-Kennlinie MTW 500d K4

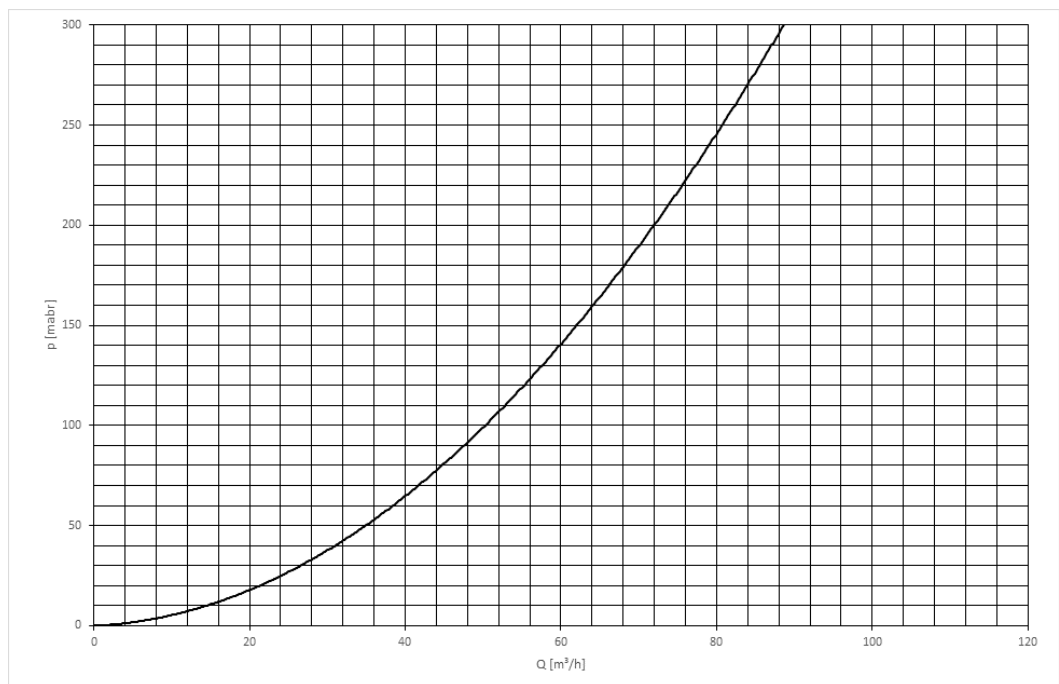

Contents

Safety	38
Proper use	38
Safety	38
Danger from welding fumes	39
MTG d, MTW d, MHP d - General	40
Up/Down function	40
JobMaster function	40
MTG 400d K4, MTW 500d K4 - General	42
General	42
Standard values for extraction units	42
Air chamber	42
Up/Down function	43
Fitting wearing parts to the torch neck	44
MTG d, MTW d - Fitting wearing parts to the torch body	44
MTG 400d K4, MTW 500d K4 - Fitting wearing parts	44
Fitting the ML torch body to the MHP hosepack	46
Assembling the Multilock welding torch	46
Fitting the inner liners	47
Checking the clamping nipple	47
Fitting the steel inner liner	47
Fitting the plastic inner liner (F, F++)	49
Fitting the plastic inner liner (Fronius connection with wirefeeding nozzle)	50
Fitting the plastic inner liner (Euro)	51
Start-up	52
Connecting the welding torch	52
Connecting the extractor	52
Twisting the Multilock welding torch body	53
Changing the torch body on a Multilock welding torch	54
Prisma holder for machine welding torch	55
Care and maintenance	56
General	56
Recognising faulty wearing parts	56
Maintenance at every start-up	56
Maintenance every time the wirepool/basket-type spool is changed:	57
Troubleshooting	59
Troubleshooting	59
Technical data	65
General	65
Gas-cooled welding torch - MTG 250d - 500d	65
Gas-cooled torch body - MTB 250i, 320i, 330i, 400i, 550i G ML	65
Gas-cooled hosepack - MHP 400d G ML	66
Gas-cooled hosepack - MHP 500d G ML M	66
Water-cooled welding torch - MTW 250d - 700d	66
Water-cooled torch body - MTB 250i, 330i, 400i, 500i, 700i W ML	67
Water-cooled hosepack - MHP 500d, 700d W ML	68
Water-cooled hosepack - MHP 700d W ML M	68
MTG 400d K4	69
MTG 400d K4 extraction characteristic	69
MTW 500d K4	70
MTW 500d K4 extraction characteristic	70

Safety

Proper use

The MIG/MAG manual welding torch is intended solely for MIG/MAG welding in manual applications.

Any use above and beyond this purpose is deemed improper. The manufacturer shall not be held liable for any damage arising from such usage.

Proper use includes:

- Carefully reading and following all the instructions given in the operating instructions
 - Performing all stipulated inspection and maintenance work.
-

Safety

WARNING!

Danger from incorrect operation and work that is not carried out properly.

This can result in serious personal injury and damage to property.

- ▶ All the work and functions described in this document must only be carried out by technically trained and qualified personnel.
 - ▶ Read and understand this document in full.
 - ▶ Read and understand all safety rules and user documentation for this device and all system components.
-

WARNING!

Danger from electrical current.

This can result in serious personal injury and damage to property.

- ▶ Before starting work, switch off all devices and components involved and disconnect them from the grid.
 - ▶ Secure all devices and components involved so they cannot be switched back on.
-

WARNING!

Danger from electric current due to defective system components and incorrect operation.

This can result in serious personal injury and damage to property.

- ▶ All cables, leads and hosepacks must always be securely connected, undamaged and correctly insulated.
 - ▶ Only use adequately dimensioned cables, leads and hosepacks.
-

WARNING!

Risk of coolant escaping.

This can result in serious personal injury and damage to property.

- ▶ When disconnecting a welding torch from the cooling unit or other system components, always seal the coolant hoses using the plastic seal attached to the torch.
-

⚠ WARNING!**Danger due to hot system components and/or equipment.**

Can result in serious burns or scalding.

- ▶ Before starting work, allow all hot system components and/or equipment to cool to +25°C/+77°F (e.g., coolant, water-cooled system components, wire-feeder drive motor, etc.)
- ▶ Wear suitable protective equipment (e.g., heat-resistant gloves, safety goggles, etc.) if cooling down is not possible.

⚠ WARNING!**Danger from contact with toxic welding fumes.**

This can result in serious personal injuries.

- ▶ Always extract welding fumes.
- ▶ Ensure an adequate supply of fresh air. Ensure that there is a ventilation rate of at least 20 m³ (169070.1 US gi) per hour at all times.
- ▶ If in doubt, a safety engineer should be commissioned to check the pollution level in the workplace.

⚠ CAUTION!**Danger from operation without coolant.**

This can result in damage to property.

- ▶ Never operate water-cooled welding torches without coolant.
- ▶ During welding, ensure that the coolant is circulating correctly – this will be the case for Fronius cooling units if a regular return flow of coolant can be seen in the coolant container of the cooling unit.
- ▶ The manufacturer will not be liable for any damages due to non-observance of the above mentioned points. All claims against the warranty are void.

Danger from welding fumes**⚠ WARNING!****Danger from the fumes produced during welding, which contain harmful gases and vapours.**

These can cause severe damage to health.

- ▶ A welding operation is not permitted without an extraction unit that is switched on.
- ▶ Under certain circumstances, the sole use of a fume extraction torch is not sufficient.
In this case, install an additional extractor to reduce the pollution level in the workplace.
- ▶ If in doubt, a safety engineer should be commissioned to check the pollution level in the workplace.

MTG d, MTW d, MHP d - General

Up/Down function

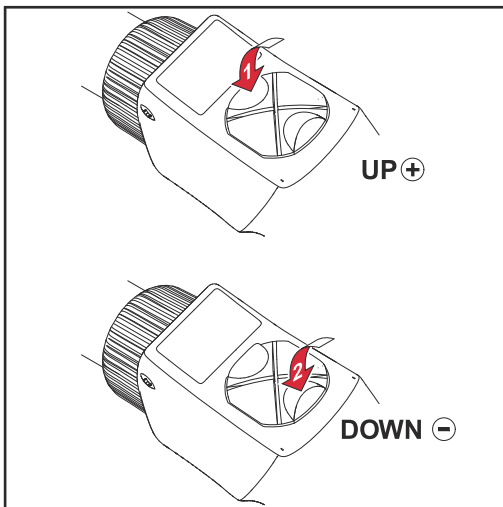

- Select one of the following parameters on the power source:
 - Wire feed speed
 - Job number
- Set the parameters using the Up/Down function

IMPORTANT! In the "MIG/MAG Standard Synergic and Pulse Synergic Welding" operating modes, extra parameters can be set.

JobMaster function

IMPORTANT! Coded messages can appear on the JobMaster. These correspond to the service code displayed on the control panel at the same time (see the "Troubleshooting" section of the power source operating instructions).

SynchroPulse (option) - no symbol lights up on the JobMaster (see the "MIG/MAG welding" section of the power source operating instructions).

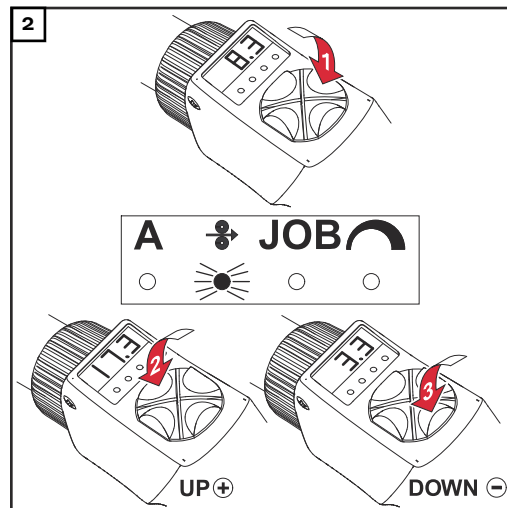
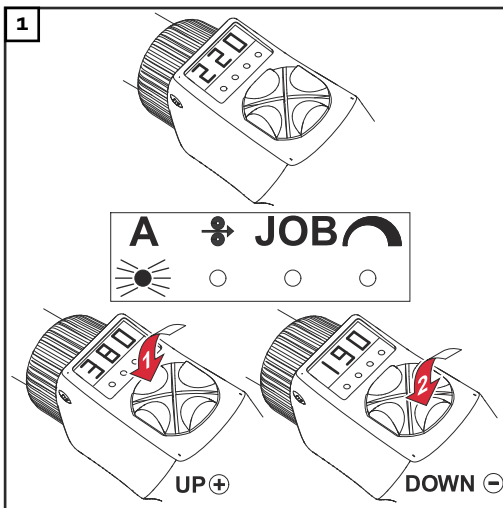

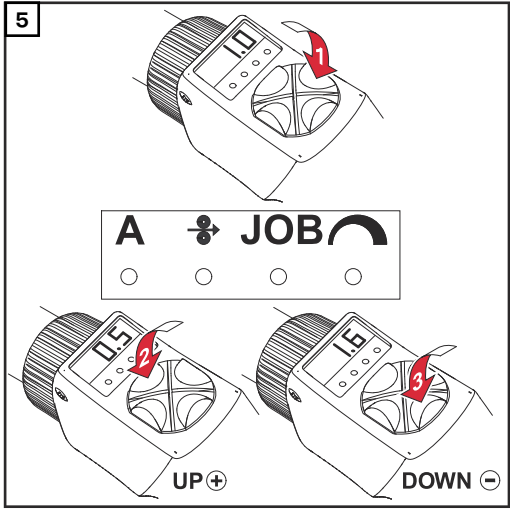
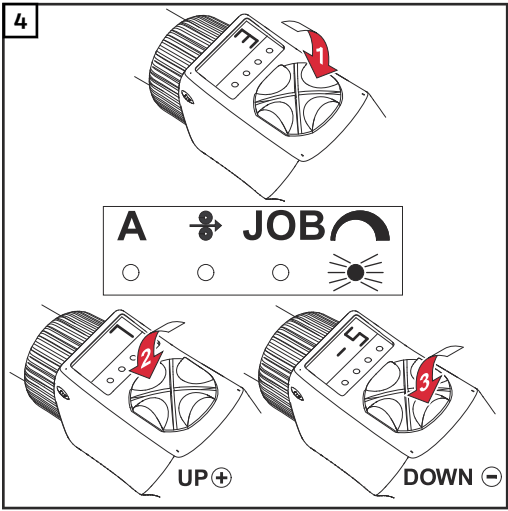
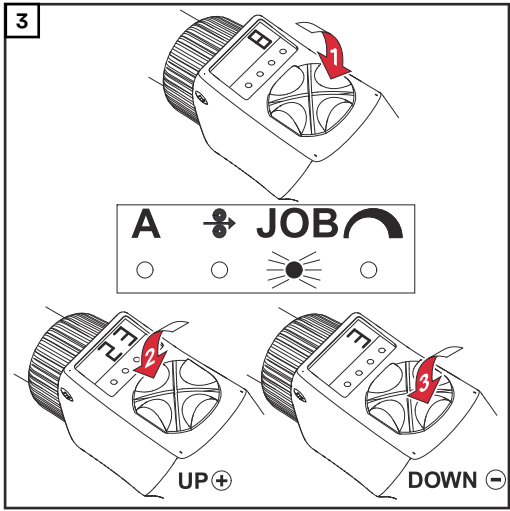

MTG 400d K4, MTW 500d K4 - General

General

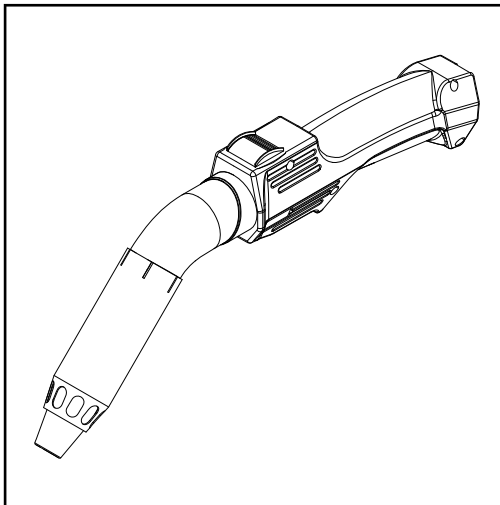

The MTG 400d K4 and MTW 500d K4 fume extraction torches capture the harmful welding fumes directly at source. The welding fumes are extracted, before they get into the welder's breathing zone. Legal specified values for the maximum workplace concentration (MAK) are adhered to or undercut.

Standard values for extraction units

The extraction unit for the fume extraction torch must comply with the following specifications:

Suction power	Approx. 100 m ³ /h
Negative pressure values	Between 0.05 and 0.2 bar (between 5000 and 20000 Pa)

Air chamber

The quantity of extracted welding fumes can be continuously controlled between 10 and 100% using the air chamber during the welding process.

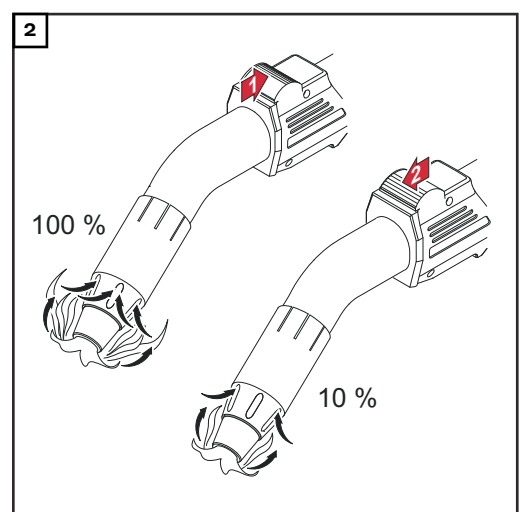
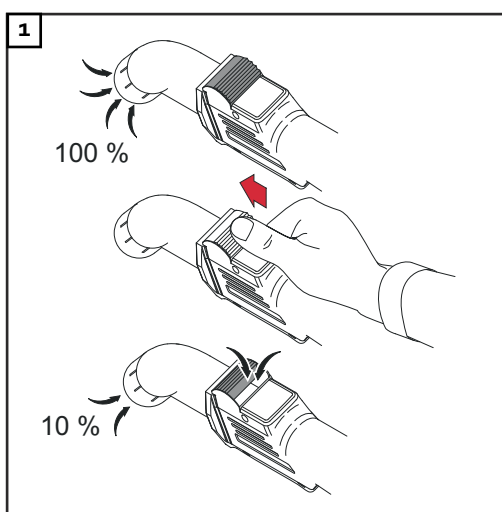

IMPORTANT! Regulation of the extracted welding fume quantity is required if the shielding gas is extracted with the welding fumes (e.g. when welding in a corner position).

**Up/Down func-
tion**

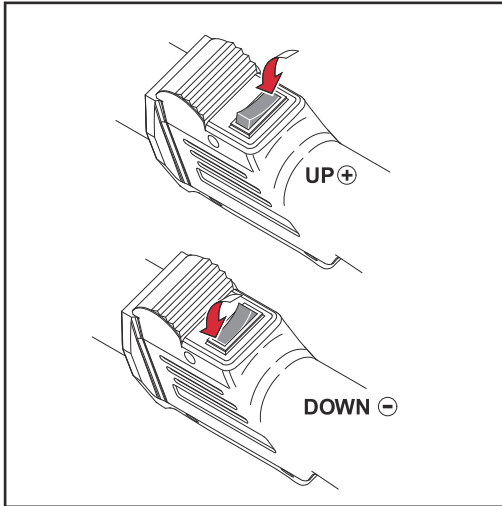

Fitting wearing parts to the torch neck

MTG d, MTW d -
Fitting wearing
parts to the
torch body

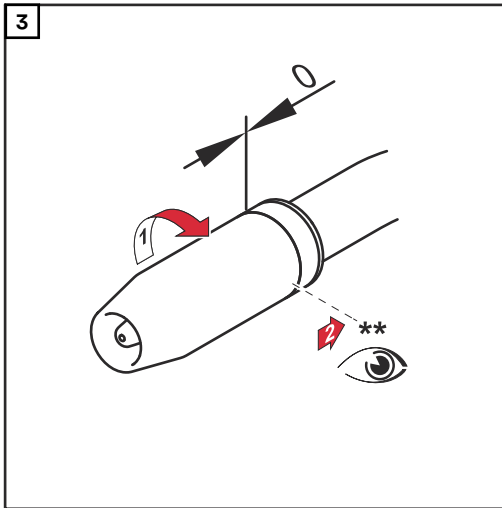
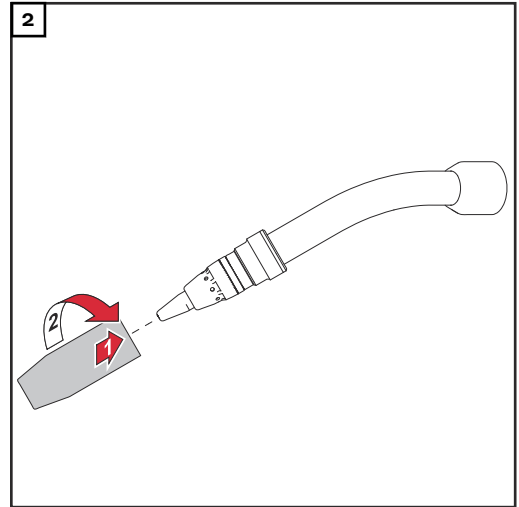
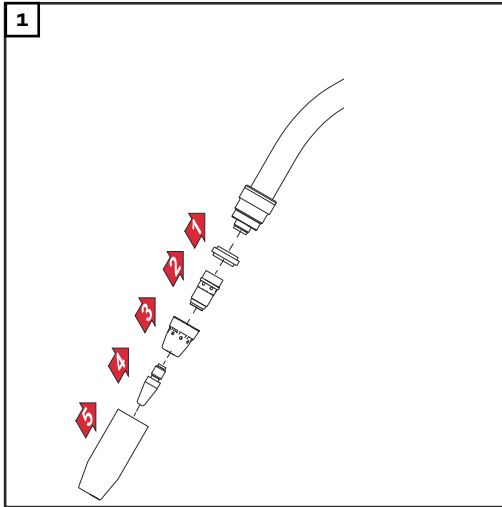

** Screw on and tighten the gas nozzle as far as it will go

MTG 400d K4,
MTW 500d K4 -
Fitting wearing
parts

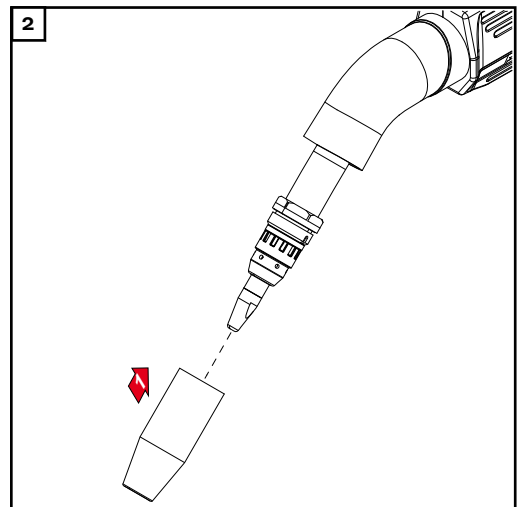
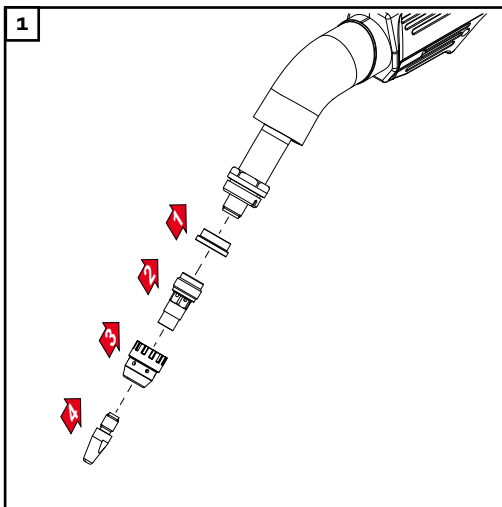

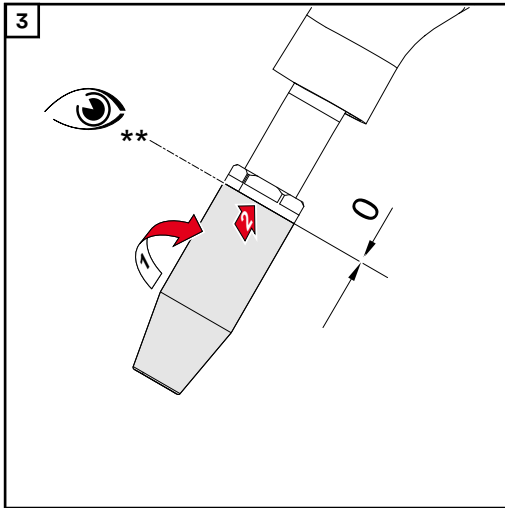

** Screw on and tighten the gas nozzle as far as it will go

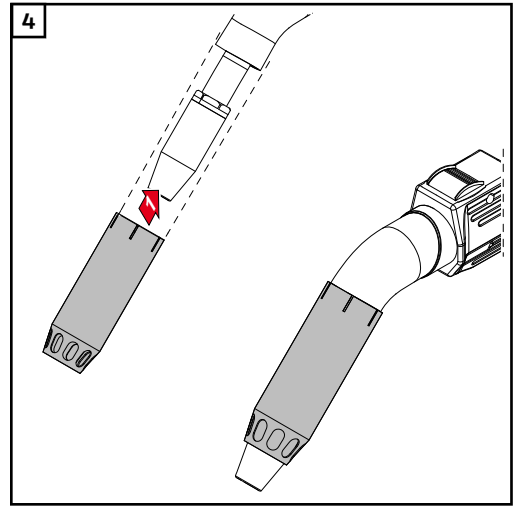

Fit the extraction nozzle

Fitting the ML torch body to the MHP hosepack

Assembling the Multilock welding torch

NOTE!

Risk of damage to the welding torch. Always tighten the union nut on the torch body as far as it will go.

NOTE!

In the case of water-cooled welding torches, increased resistance may arise when tightening the union nut due to the construction of the welding torch. This is normal. Always tighten the union nut on the torch body as far as it will go.

NOTE!

Before fitting a torch body, ensure that the interface between the torch body and the hosepack is clean and undamaged.

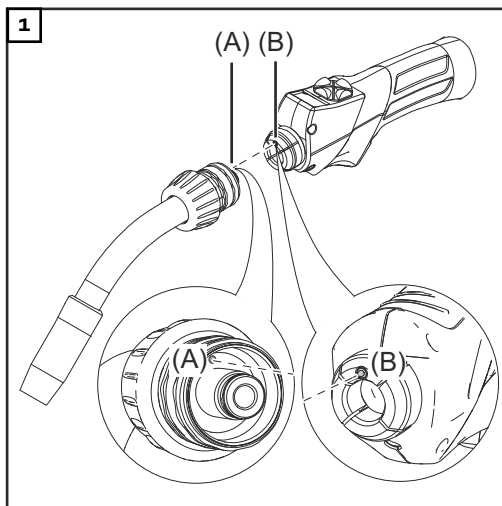

NOTE!

The torch body is in the 0° position when the dowel pin (A) on the hosepack engages in the locating hole (B) in the torch body.

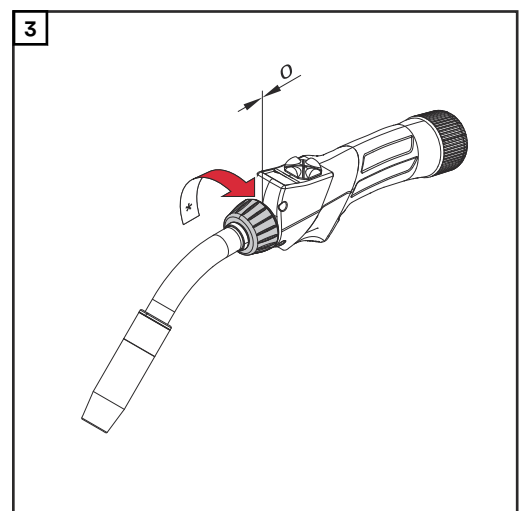
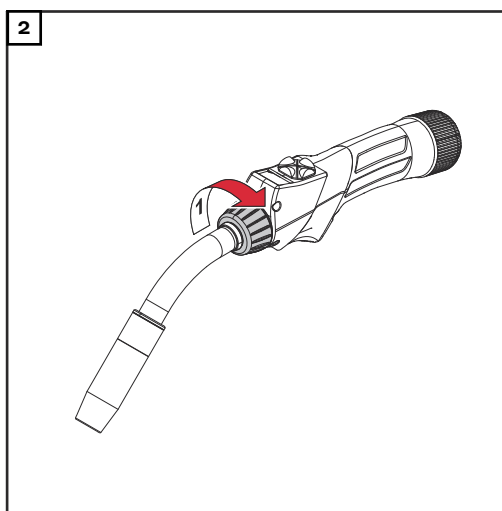

* Ensure that the union nut is tightened as far as it will go.

Fitting the inner liners

Checking the clamping nipple

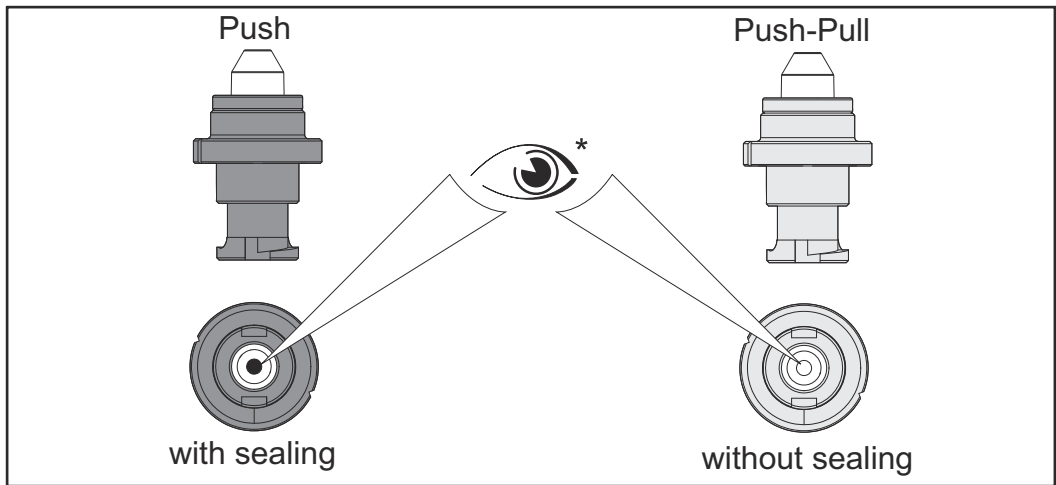

* Check the clamping nipple before commissioning and whenever the inner liner is changed. To do so, carry out a visual inspection:

- Left: brass clamping nipple with seal ring. You cannot see through the seal ring.
- Right: silver clamping nipple with see-through bushing

NOTE!

Incorrect or defective clamping nipple in push applications

Causes gas loss and poor weld properties

- ▶ use brass clamping nipples to minimise gas loss
- ▶ check that the seal ring is intact

NOTE!

Incorrect clamping nipple in push-pull applications

Tangled wire and increased abrasion in the inner liner when using a clamping nipple with seal ring

- ▶ use silver clamping nipple to facilitate wirefeeding

Fitting the steel inner liner

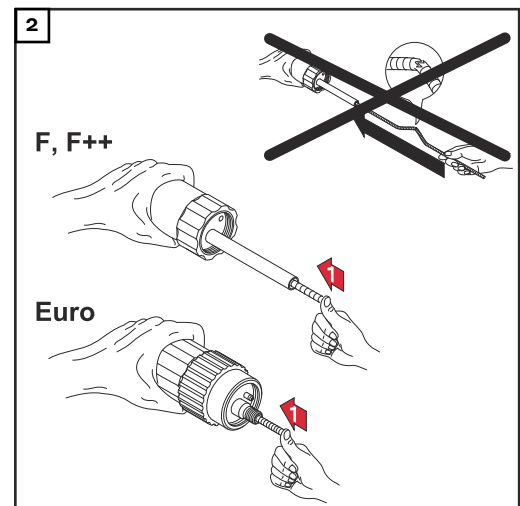
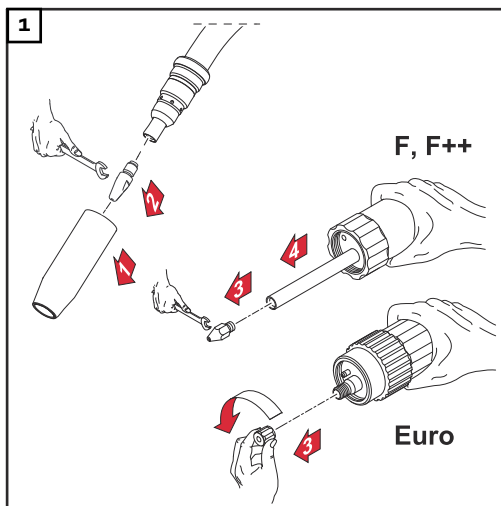

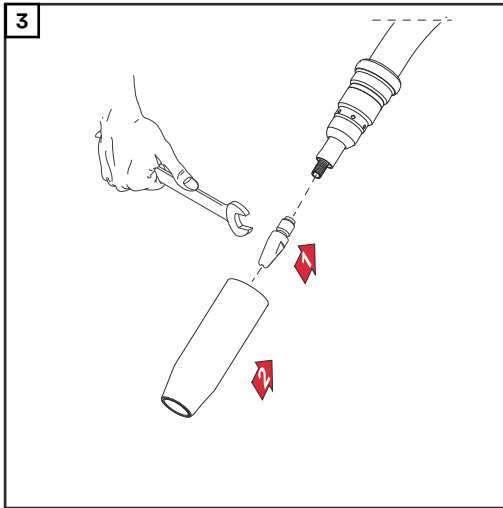

F++, F:

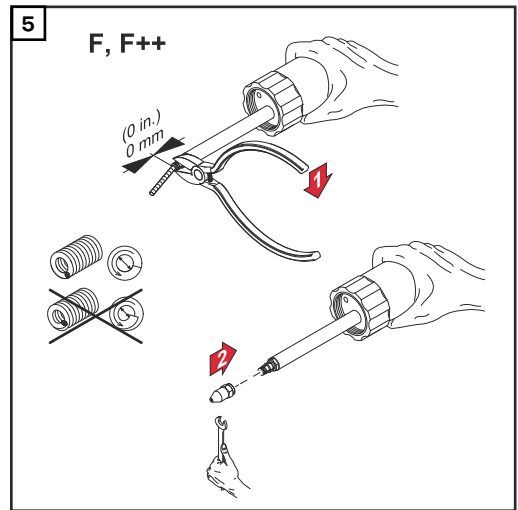
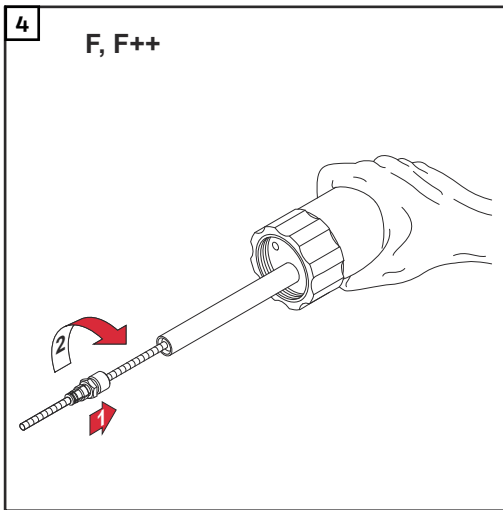

Euro:

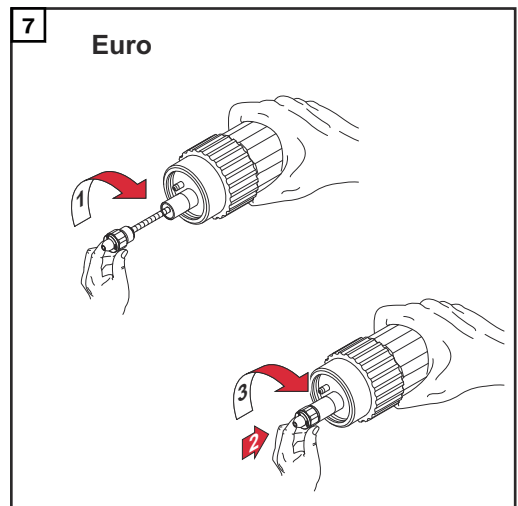
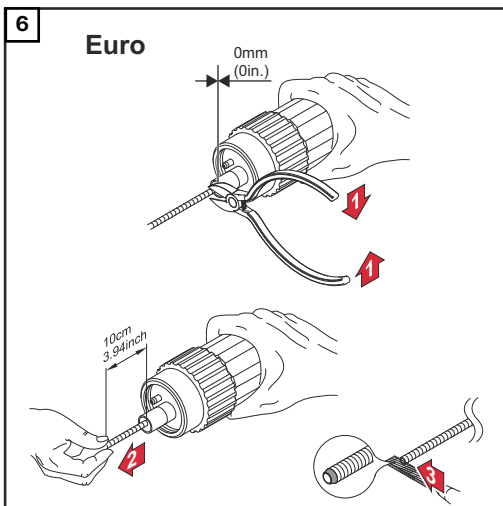

Fitting the plastic inner liner (F, F++)

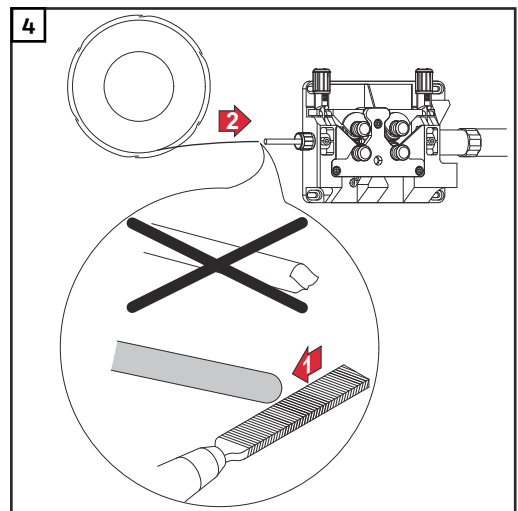
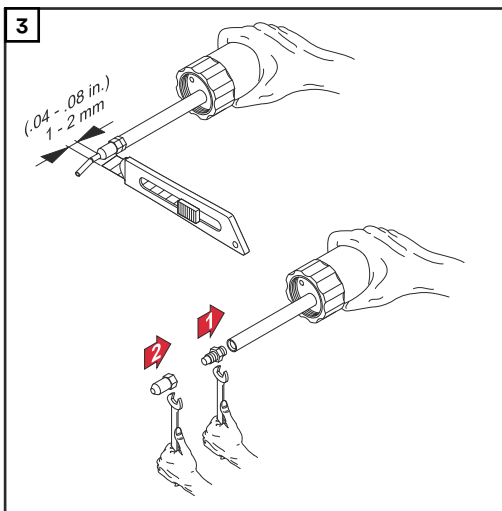
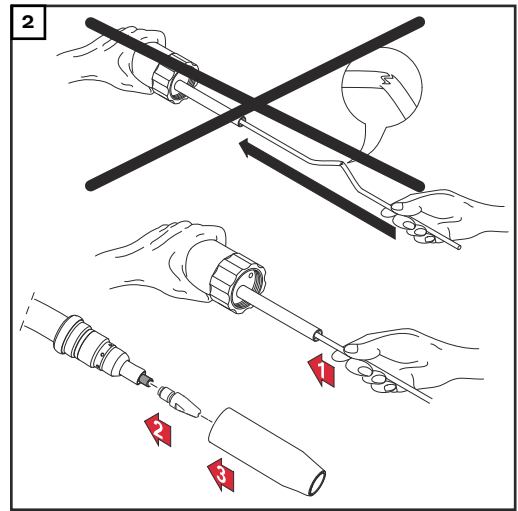
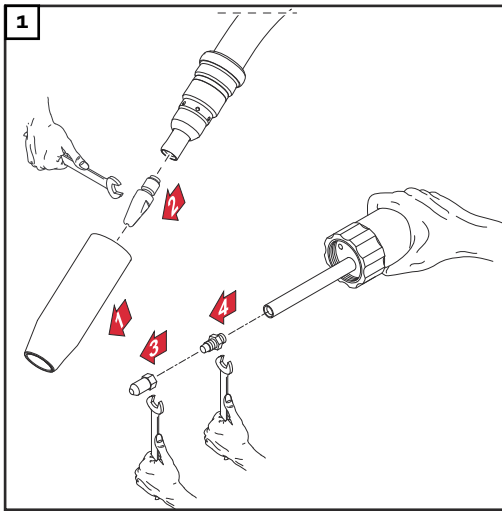

EN

Fitting the plastic inner liner (Fronius connection with wirefeeding nozzle)

NOTE!

Round off the end of the wire electrode before feeding it in.

Applicable for Teflon liners, combination liners and Graphite liners

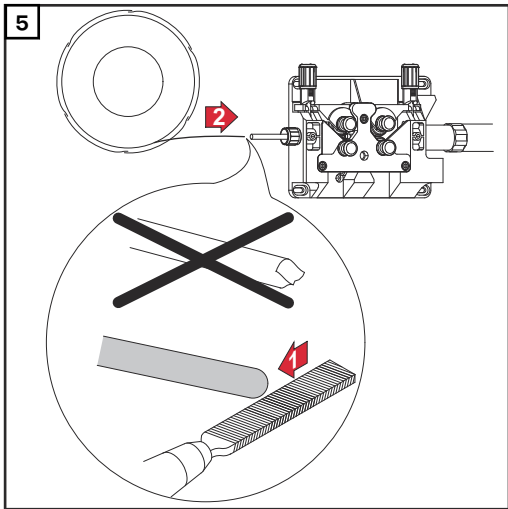
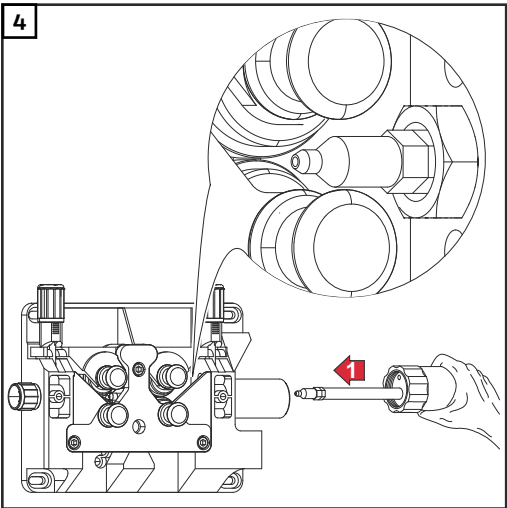
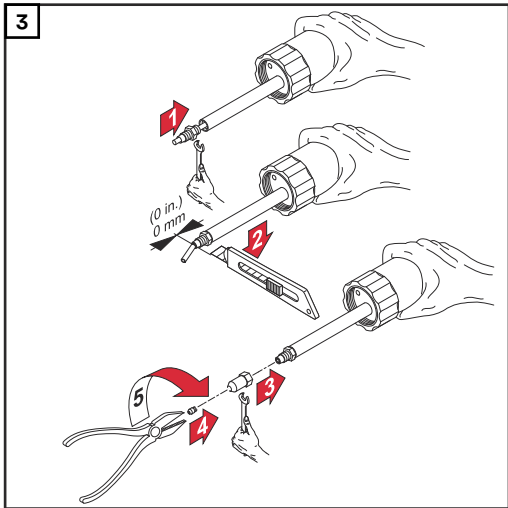
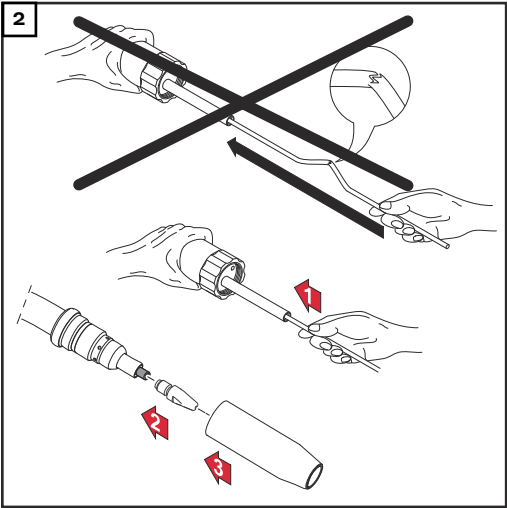
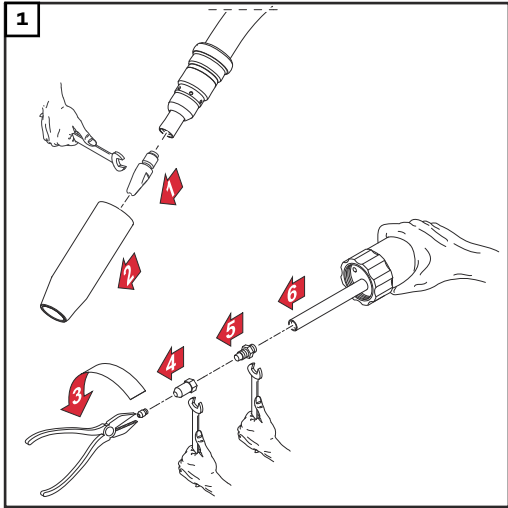

Fitting the plastic inner liner (Euro)

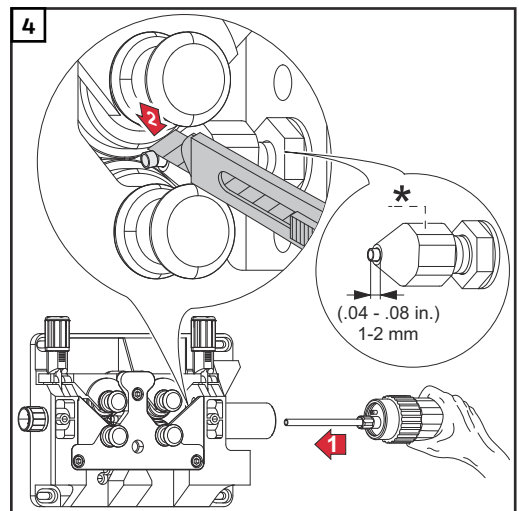
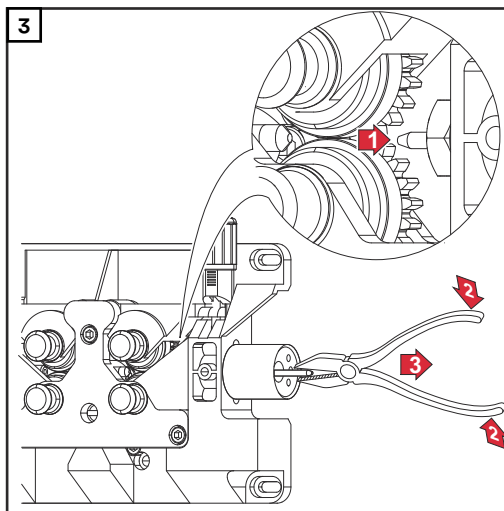
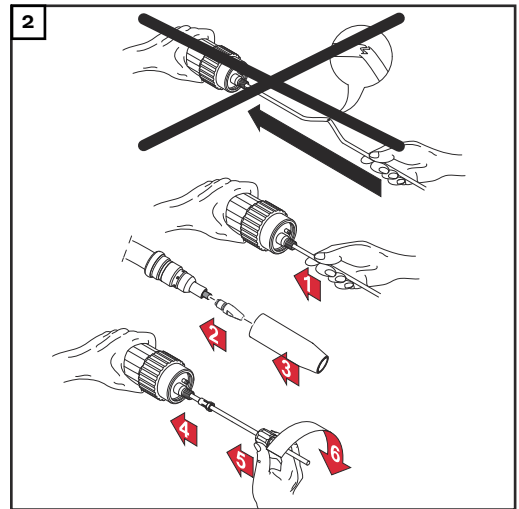
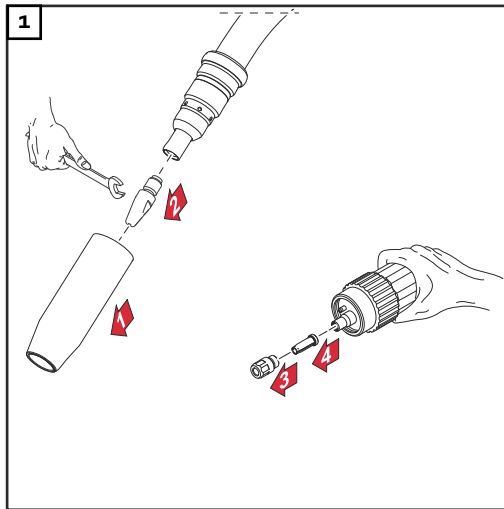

* Infeed tube option (42,0001,5421)

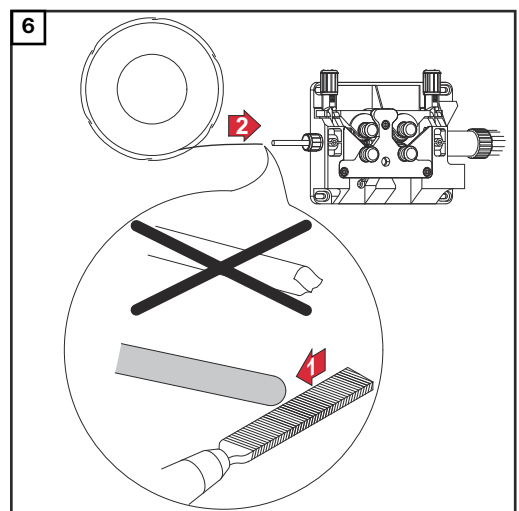
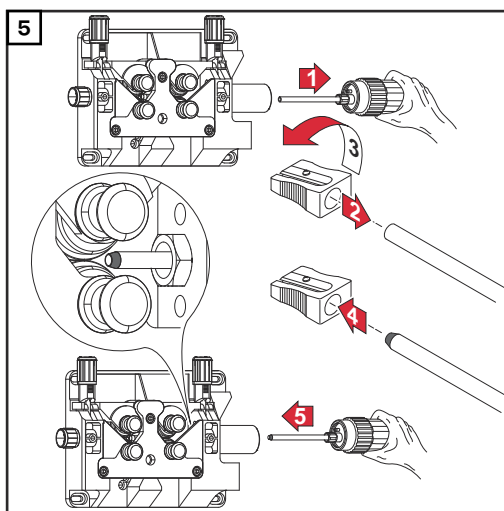

Start-up

Connecting the welding torch

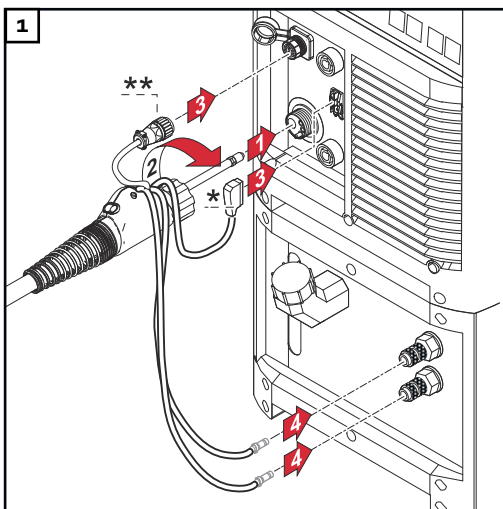

- * LocalNet plug (Standard or Up/Down welding torches)
- ** JobMaster plug (JobMaster welding torches)

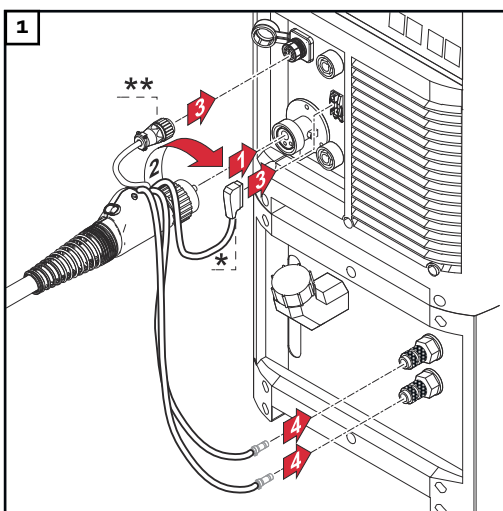

- * LocalNet plug (Standard or Up/Down welding torches)
- ** JobMaster plug (JobMaster welding torches)

Connecting the extractor

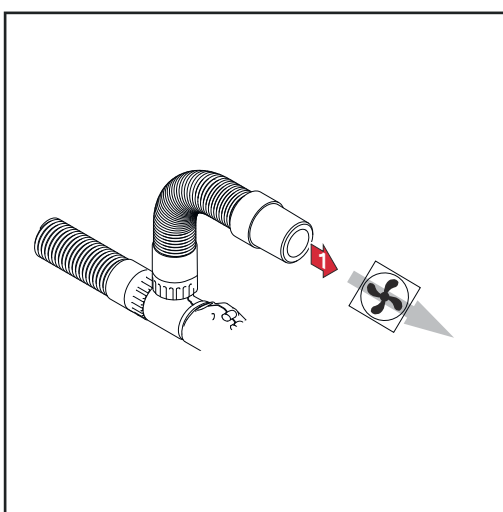

- 1 Connect the hose for the extractor corresponding to the standard values for extraction units to the extraction unit

Twisting the Multilock welding torch body

CAUTION!

Risk of burns from hot coolant and hot torch body.

- ▶ Before carrying out any work, allow the coolant and torch body to cool to room temperature (+25°C, +77°F).

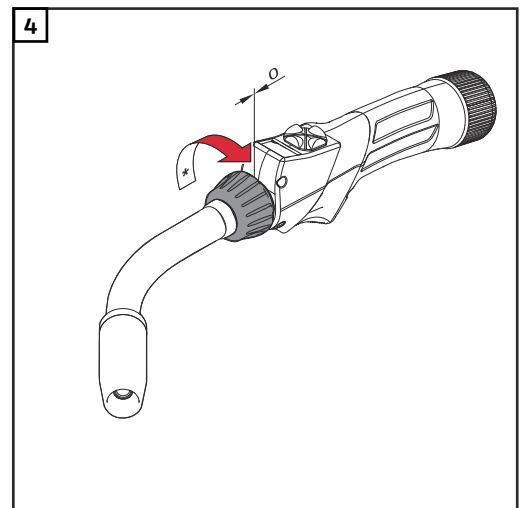
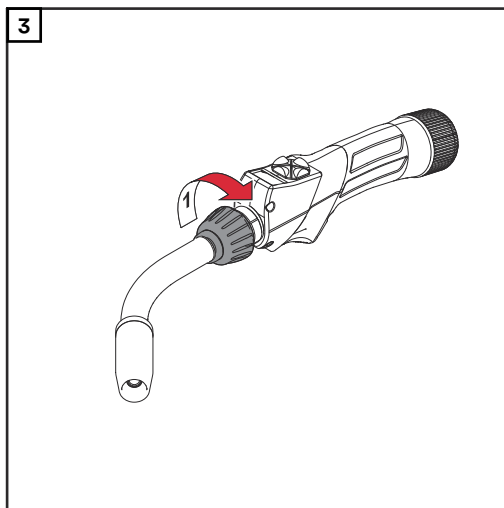
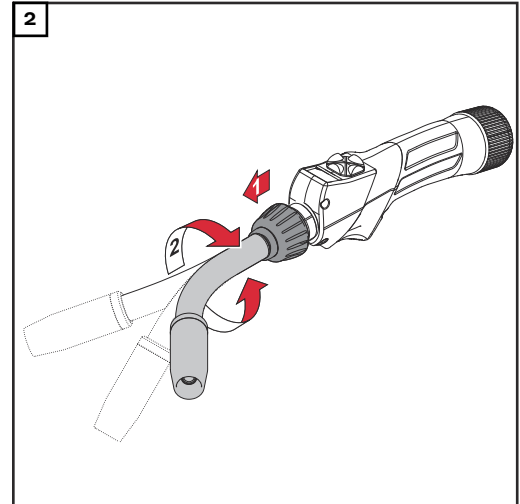
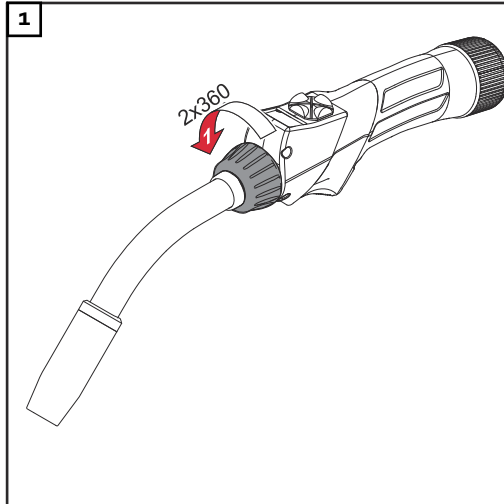

- * Ensure that the union nut is tightened as far as it will go.

Changing the torch body on a Multilock welding torch

⚠ CAUTION!

Risk of burns from hot coolant and hot torch body.

This can result in severe scalds.

- ▶ Before carrying out any work, allow the coolant and torch body to cool to room temperature (+25°C, +77°F).

NOTE!

Some coolant will always remain in the torch body.

Only remove the torch body with the gas nozzle pointing downwards.

NOTE!

Before fitting a torch body, ensure that the interface between the torch body and the hosepack is clean and undamaged.

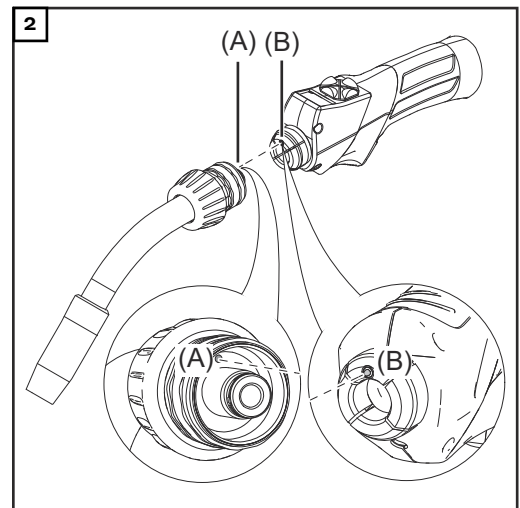
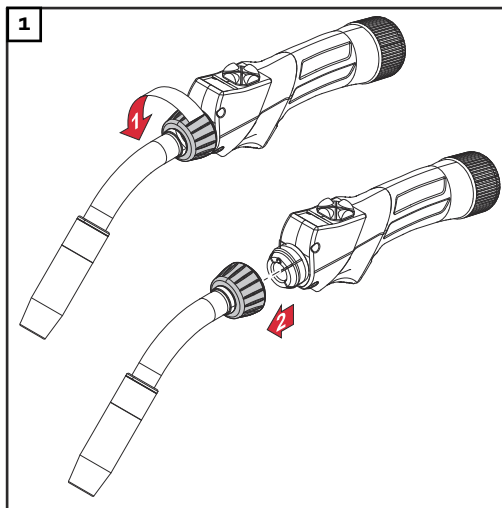

NOTE!

The torch body is in the 0° position when the dowel pin (A) on the hosepack engages in the locating hole (B) in the torch body.

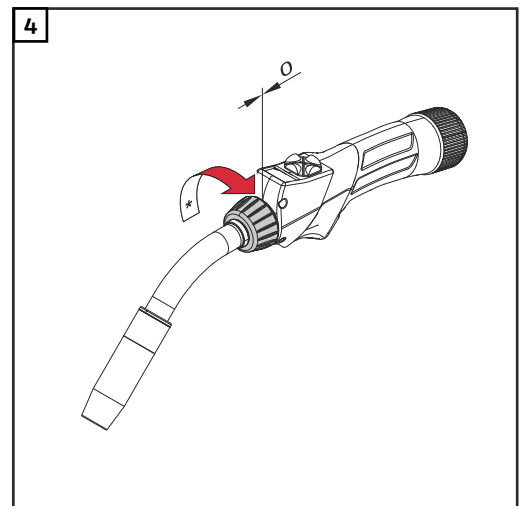
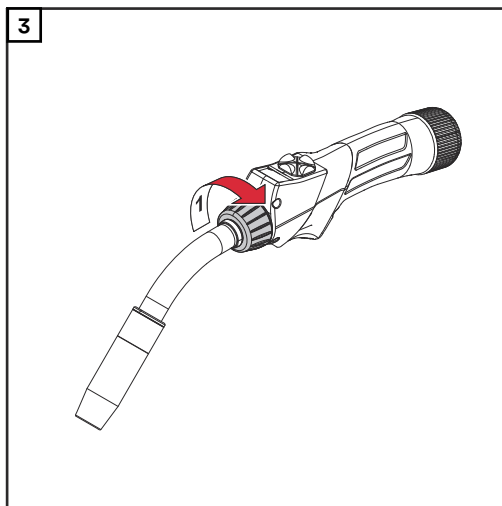

* Ensure that the union nut is tightened as far as it will go.

**Prisma holder
for machine wel-
ding torch**

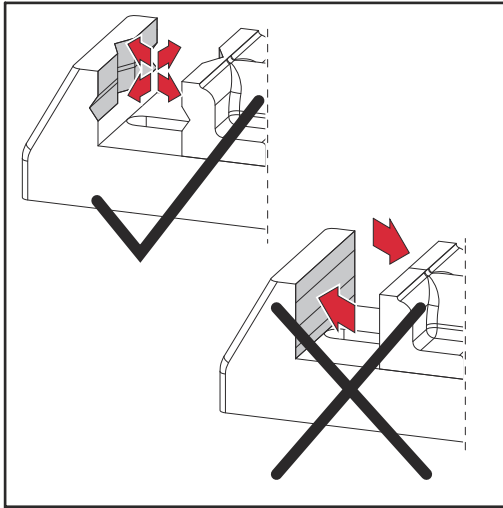

Ensure that the machine welding torch to be worked on is only ever clamped in a suitable Prisma holder.

Care and maintenance

General

Regular preventive maintenance of the welding torch is essential if trouble-free operation is to be ensured. The welding torch is subjected to high temperatures and heavy soiling. The welding torch therefore requires more frequent maintenance than other components in the welding system.

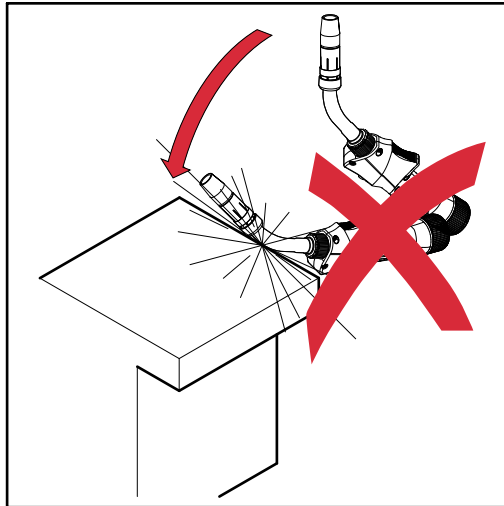

CAUTION!

Risk of damage from improper handling of the welding torch.

This can result in severe damage to property.

- ▶ Do not strike the welding torch on hard objects.
- ▶ Avoid scoring and scratches on the contact tip.
- ▶ Do not bend the torch body under any circumstances.

Recognising faulty wearing parts

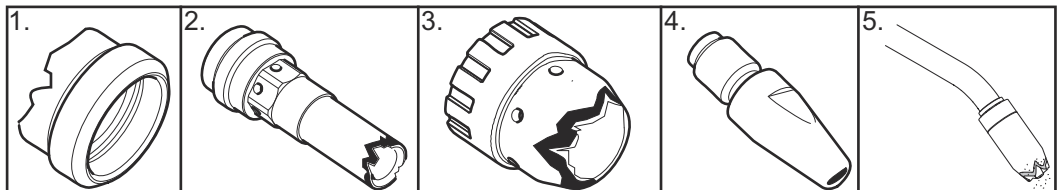

1. Insulating parts
 - Burned-off outside edges, notches
2. Nozzle fittings
 - Burned-off outside edges, notches
 - Heavily covered in welding spatter
3. Spatter guard
 - Burned-off outside edges, notches
4. Contact tips
 - Worn-out (oval) wire entry and wire exit holes
 - Heavily covered in welding spatter
 - Penetration on the tip of the contact tip
5. Gas nozzles
 - Heavily covered in welding spatter
 - Burned-off outside edges
 - Notches

Maintenance at every start-up

- Check wearing parts
 - replace faulty wearing parts
- Remove welding spatter from gas nozzle

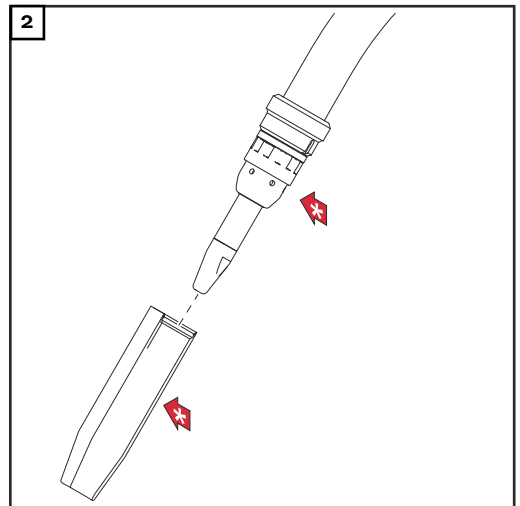
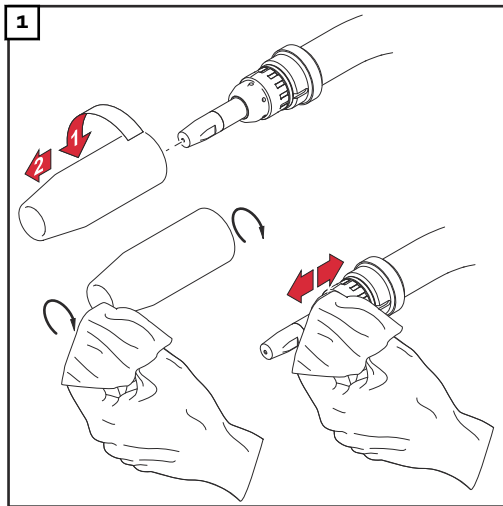

- * Check the gas nozzle, spatter guard and insulation for damage and replace any damaged components.
- Also at every start-up when using water-cooled welding torches:
 - check all coolant connections for tightness (no leaks)
 - check that the coolant can flow unhindered

Maintenance every time the wirepool/ basket-type spool is changed:

- Clean wirefeeding hose with reduced compressed air
- Recommended: replace the inner liner. Clean the wearing parts before fitting the new inner liner

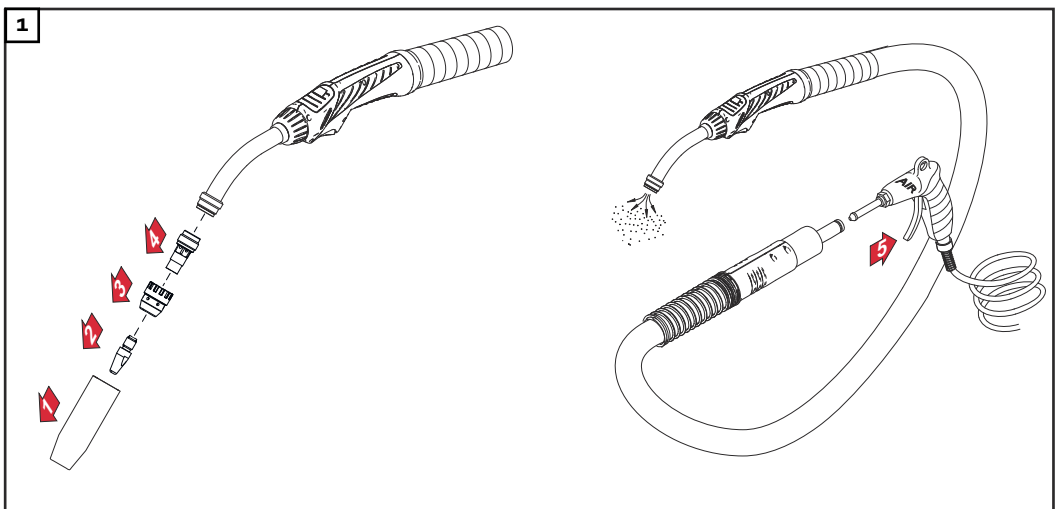

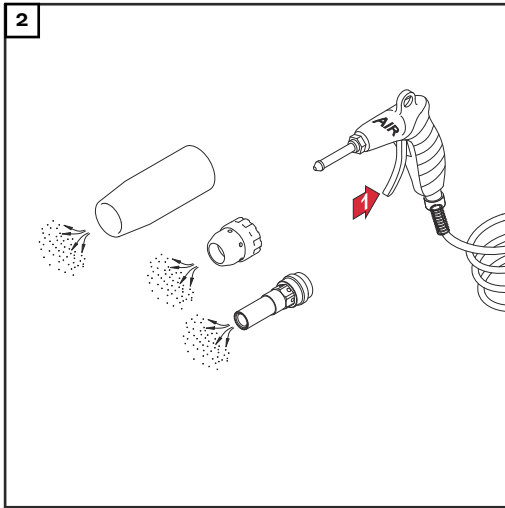

Troubleshooting

Troubleshooting

No welding current

Power source mains switch is on, indicators on the power source are lit up, shielding gas available

Cause: Grounding (earthing) connection is incorrect

Remedy: Establish a proper grounding (earthing) connection

Cause: There is a break in the current cable in the welding torch

Remedy: Replace welding torch

Nothing happens when the torch trigger is pressed

Power source mains switch is on, indicators on the power source are lit up

Cause: The FSC ('Fronius System Connector' central connector) is not plugged in properly

Remedy: Push on the FSC as far as it will go

Cause: Welding torch or welding torch control line is faulty

Remedy: Replace welding torch

Cause: Interconnecting hosepack faulty or not connected properly

Remedy: Connect interconnecting hosepack properly
Replace faulty interconnecting hosepack

Cause: Faulty power source

Remedy: Contact After-Sales Service

No shielding gas

All other functions are OK

Cause: Gas cylinder is empty

Remedy: Change the gas cylinder

Cause: Gas pressure regulator is faulty

Remedy: Replace gas pressure regulator

Cause: The gas hose is not connected, or is damaged or kinked

Remedy: Fit gas hose, lay out straight Replace faulty gas hose

Cause: Welding torch is faulty

Remedy: Replace welding torch

Cause: Gas solenoid valve is faulty

Remedy: Contact After-Sales Service (arrange for gas solenoid valve to be replaced)

Poor weld properties

Cause: Incorrect welding parameters

Remedy: Correct settings

Cause: Poor grounding (earthing) connection

Remedy: Ensure good contact to workpiece

Cause: Too little or no shielding gas

Remedy: Check the pressure regulator, gas hose, gas solenoid valve and welding torch shielding gas connection. On gas-cooled welding torches, inspect the gas seals, use a suitable inner liner

Cause: Welding torch is leaking

Remedy: Replace welding torch

Cause: Contact tip is too large or worn out

Remedy: Replace contact tip

Cause: Wrong wire alloy or wrong wire diameter

Remedy: Check wirespool/basket-type spool in use

Cause: Wrong wire alloy or wrong wire diameter

Remedy: Check weldability of the base material

Cause: The shielding gas is not suitable for this wire alloy

Remedy: Use the correct shielding gas

Cause: Unfavourable welding conditions: shielding gas is contaminated (by moisture, air), inadequate gas shield (weld pool "boiling", draughts), contaminants in the workpiece (rust, paint, grease)

Remedy: Optimise the welding conditions

Cause: Shielding gas escaping at clamping nipple

Remedy: Use the correct clamping nipple

Cause: Clamping nipple seal ring defective, shielding gas escaping at clamping nipple

Remedy: Replace clamping nipple to ensure a gas-tight seal

Cause: Welding spatter in the gas nozzle

Remedy: Remove welding spatter

Cause: Turbulence caused by too high a rate of shielding gas flow

Remedy: Reduce shielding gas flow rate, recommended:
shielding gas flow rate (l/min) = wire diameter (mm) x 10
(e.g. 16 l/min for 1.6 mm wire electrode)

Cause: Distance between the welding torch and the workpiece too great

Remedy: Reduce the distance between the welding torch and the workpiece (approx. 10 - 15 mm / 0.39 - 0.59 in.)

Cause: Tilt angle of the welding torch is too great

Remedy: Reduce the tilt angle of the welding torch

Cause: Wirefeed components do not match the diameter of the wire electrode/wire electrode material

Remedy: Use the correct wirefeed components

Poor wirefeeding

Cause: Depending on the system, brake force in wirefeeder or power source set too high

Remedy: Reduce the brake force

Cause: Hole in the contact tip is displaced

Remedy: Change the contact tip

Cause: The inner liner or wire-guide insert is defective

Remedy: Check the inner liner and wire-guide insert for kinks, dirt, etc. Change the defective inner liner or wire-guide insert

Cause: The feed rollers are not suitable for the wire electrode being used

Remedy: Use suitable wirefeeder rollers

Cause: Wirefeeder rollers have the wrong contact pressure

Remedy: Optimise contact pressure

Cause: The wirefeeder rollers are soiled or damaged

Remedy: Clean or replace wirefeeder rollers

Cause: Inner liner wrongly fitted or kinked

Remedy: Replace inner liner

Cause: The inner liner has been cut too short

Remedy: Replace the inner liner and cut the new inner liner to the correct length

Cause: Wire electrode worn due to excessive contact pressure on the wirefeeder rollers

Remedy: Reduce contact pressure on the wirefeeder rollers

Cause: Wire electrode contains impurities or is corroded

Remedy: Use high-quality wire electrode with no impurities

Cause: For steel inner liners: use of uncoated inner liner

Remedy: Use a coated inner liner

Cause: Clamping nipple in wire entry and wire exit area deformed (oval, knocked out), shielding gas escaping at clamping nipple

Remedy: Replace clamping nipple to ensure a gas-tight seal

The gas nozzle becomes very hot

Cause: No thermal dissipation as the gas nozzle is too loose

Remedy: Screw on the gas nozzle as far as it will go

The welding torch becomes very hot

Cause: Only on Multilock welding torches: torch neck union nut is loose

Remedy: Tighten the union nut

Cause: Welding torch operated above the maximum welding current

Remedy: Reduce welding power or use a more powerful welding torch

Cause: The specification of the welding torch is inadequate

Remedy: Observe the duty cycle and loading limits

Cause: Only on water-cooled systems: Inadequate coolant flow

Remedy: Check coolant level, coolant flow, coolant contamination, the routing of the hosepack, etc.

Cause: The tip of the welding torch is too close to the arc

Remedy: Increase stick-out

Contact tip has a short service life

Cause: Incorrect wirefeeder rollers

Remedy: Use correct wirefeeder rollers

Cause: Wire electrode worn due to excessive contact pressure on the wirefeeder rollers

Remedy: Reduce contact pressure on the wirefeeder rollers

Cause: Wire electrode contains impurities/is corroded

Remedy: Use high-quality wire electrode with no impurities

Cause: Uncoated wire electrode

Remedy: Use wire electrode with suitable coating

Cause: Wrong dimension of contact tip

Remedy: Use a contact tip of the correct dimension

Cause: Duty cycle of welding torch has been exceeded

Remedy: Shorten the duty cycle or use a more powerful welding torch

Cause: Contact tip has overheated. No thermal dissipation as the contact tip is too loose

Remedy: Tighten the contact tip

NOTE!

When using CrNi, the contact tip may be subject to a higher degree of wear due to the nature of the surface of the CrNi wire electrode.

Torch trigger malfunction

Cause: Defective plug connection between welding torch and power source

Remedy: Establish proper plug connections / have power source or welding torch serviced

Cause: Build up of dirt between torch trigger and torch trigger housing

Remedy: Clean away the dirt

Cause: Control line is faulty

Remedy: Contact After-Sales Service

Weld seam porosity

Cause: Spattering in the gas nozzle causing inadequate gas shield for weld seam

Remedy: Remove welding spatter

Cause: Holes in gas hose or hose is not connected properly

Remedy: Replace gas hose

Cause: O-ring on central connector has been cut or is faulty

Remedy: Replace O-ring

Cause: Moisture/condensation in the gas line

Remedy: Dry gas line

Cause: Gas flow is either too high or too low

Remedy: Correct gas flow

Cause: Insufficient gas flow at start or end of welding

Remedy: Increase gas pre-flow and gas post-flow

Cause: Rusty or poor quality wire electrode

Remedy: Use high-quality wire electrode with no impurities

Cause: Applies to gas-cooled welding torches: gas is escaping through a non-insulated inner liner

Remedy: Use only insulated inner liners with gas-cooled welding torches

Cause: Too much parting agent applied

Remedy: Remove excess parting agent/apply less parting agent

Cause: Too much suction

Remedy: Reduce suction

Too little suction

Cause: Hole(s) in the extraction hose

Remedy: Replace extraction hose

Cause: Extraction unit filter blocked

Remedy: Replace extraction unit filter

Cause: Air passages blocked

Remedy: Remove blockages

Cause: Extraction capacity of the extraction unit too low;
OPT/i FumeEx configured incorrectly

Remedy: Use an extraction unit with a higher extraction capacity;
increase the extraction capacity

Technical data

General

Voltage measurement (V-Peak):

- for manually-operated welding torches: 113 V
- for mechanically-driven welding torches: 141 V

Torch trigger technical data:

- $U_{max} = 5 \text{ V}$
- $I_{max} = 10 \text{ mA}$

The torch trigger may only be operated in accordance with the technical data.

The product conforms to the requirements of IEC 60974-7 / - 10 Class A.

Gas-cooled welding torch - MTG 250d - 500d

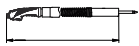
	MTG 250d	MTG 320d	MTG 400d	MTG 500d
I (amp.) 10 min/40°C CO ²	40% D.C.* 250 60% D.C.* 200 100% D.C.* 170	40% D.C.* 320 60% D.C.* 260 100% D.C.* 210	40% D.C.* 400 60% D.C.* 320 100% D.C.* 260	40% D.C.* 500 60% D.C.* 400 100% D.C.* 320
I (amp.) 10 min/40°C M21	40% D.C.* 200 60% D.C.* 160 100% D.C.* 120	40% D.C.* 260 60% D.C.* 210 100% D.C.* 160	40% D.C.* 320 60% D.C.* 260 100% D.C.* 210	40% D.C.* 400 60% D.C.* 320 100% D.C.* 260
 [mm (in.)]	0.8-1.2 (0.032-0.047)	0.8-1.6 (0.032-0.063)	1.0-1.6 (0.039-0.063)	1.0-1.6 (0.039-0.063)
 [m (ft.)]	3,5 / 4,5 (12 / 15)	3,5 / 4,5 (12 / 15)	3,5 / 4,5 (12 / 15)	3,5 / 4,5 (12 / 15)

* D.C. = Duty cycle

Gas-cooled torch body - MTB 250i, 320i, 330i, 400i, 550i G ML

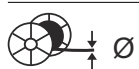
	MTB 250i G ML	MTB 320i G ML	MTB 330i G ML
I (ampere) 10 min/ 40°C M21+C1 (EN 439)	40 % ED* 250 60 % ED* 200 100 % ED* 170	40 % ED* 320 60 % ED* 260 100 % ED* 210	40 % ED* 330 60 % ED* 270 100 % ED* 220
 [mm (in.)]	0.8-1.2 (0.032-0.047)	0.8-1.6 (0.032-0.063)	0.8-1.6 (0.032-0.063)



* ED = Duty cycle

	MTB 400i G ML	MTB 550i G ML
I (ampere) 10 min/ 40°C C1 (EN 439)	-	30 % ED* 550

	MTB 400i G ML	MTB 550i G ML
I (ampere) 10 min/ 40°C M21 (EN 439)	-	30 % ED* 520
I (ampere) 10 min/ 40°C M21+C1 (EN 439)	40 % ED* 400 60 % ED* 320 100 % ED* 260	- 60 % ED* 420 100 % ED* 360
 [mm (in.)]	0.8-1.6 (0.032-0.063)	0.8-1.6 (0.032-0.063)



* ED = Duty cycle

**Gas-cooled ho-
sepack - MHP
400d G ML**

	MHP 400d G ML
I (ampere) 10 min/40 °C CO ²	40% D.C.* 400 60% D.C.* 320 100% D.C.* 260
I (ampere) 10 min/40 °C M21	40% D.C.* 320 60% D.C.* 260 100% D.C.* 210
 [mm (in.)]	0.8-1.6 (0.032-0.063)
 [m (ft.)]	3.35 / 4.35 (11 / 14)

* D.C. = Duty cycle





**Gas-cooled ho-
sepack - MHP
500d G ML M**

	MHP 500d G ML M
I (amp.) 10 min/40 °C CO ²	40% D.C.* 500 60% D.C.* 400 100% D.C.* 320
I (amp.) 10 min/40 °C M21	40% D.C.* 400 60% D.C.* 320 100% D.C.* 260
 [mm (in.)]	0.8-1.6 (0.032-0.063)
 [m (ft.)]	1.35 / 2.35 / 3.35 (4.4 / 7.7 / 14)

* D.C. = Duty cycle

**Water-cooled
welding torch -
MTW 250d -
700d**

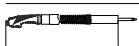

	MTW 250d	MTW 400d	MTW 500d	MTW 700d
I (ampere) 10 min/ 40°C CO ²	100% D.C.* 250	100% D.C.* 400	100% D.C.* 500	100% D.C.* 700

	MTW 250d	MTW 400d	MTW 500d	MTW 700d
I (ampere) 10 min/ 40°C M21	100% D.C.* 200	100% D.C.* 320	100% D.C.* 400	100% D.C.* 560
 [mm (in.)]	0.8-1.2 (0.032-0.047)	0.8-1.6 (0.032-0.063)	0.8-1.6 (0.032-0.063)	0.8-1.6 (0.032-0.063)
Q _{min}  [l/min (gal./min)]	1 (.26)	1 (.26)	1 (.26)	1 (.26)
P _{min}  [W]**	500 (3,5 m) 600 (4,5 m)	800 (3,5 m) 950 (4,5 m)	1400 (3,5 m) 1700 (4,5 m)	1800 (3,5 m) 2200 (4,5 m)
P _{min}  [bar (psi.)]	3 (43)	3 (43)	3 (43)	3 (43)
P _{max}  [bar (psi.)]	5 (72)	5 (72)	5 (72)	5 (72)
 [m (ft.)]	3,5 / 4,5 (12 / 15)	3,5 / 4,5 (12 / 15)	3,5 / 4,5 (12 / 15)	3,5 / 4,5 (12 / 15)



* D.C. = Duty cycle

** Lowest cooling power according to IEC 60974-2

Water-cooled torch body - MTB 250i, 330i, 400i, 500i, 700i W ML







	MTB 250i W ML	MTB 330i W ML	MTB 400i W ML	MTB 500i W ML
I (ampere) 10 min/ 40°C M21+C1 (EN 439)	100 % ED* 250	100 % ED* 330	100 % ED* 400	100 % ED* 500
 [mm (in.)]	0.8-1.2 (0.032-0.047)	0.8-1.6 (0.032-0.063)	0.8-1.6 (0.032-0.063)	1.0-1.6 (0.039-0.063)
Q _{min}  [l/min (gal./min)]	1 (0.26)	1 (0.26)	1 (0.26)	1 (0.26)

* ED = Duty cycle

	MTB 700i W ML
I (ampere) 10 min/ 40°C M21+C1 (EN 439)	100 % ED* 700
 [mm (in.)]	1.0-1.6 (0.039-0.063)
Q _{min}  [l/min (gal./min)]	1 (0.26)

* ED = Duty cycle







**Water-cooled
hosepack - MHP
500d, 700d W
ML**

	MHP 500d W ML	MHP 700d W ML
I (ampere) 10 min/40 °C CO ²	100% D.C.* 500	100% D.C.* 700
I (ampere) 10 min/40 °C M21	100% D.C.* 400	100% D.C.* 560
 [mm (in.)]	0.8-1.6 (0.032-0.063)	0.8-1.6 (0.032-0.063)
 [m (ft.)]	3.35 / 4.35 (11 / 14)	3.35 / 4.35 (11 / 14)
P _{min}  [W]**	1400 / 1700	1800 / 2200
Q _{min}  [l/min (gal./ min.)]	1 (.26)	1 (.26)
P _{min}  [bar (psi.)]	3 (43)	3 (43)
P _{max}  [bar (psi.)]	5 (72)	5 (72)

* D.C. = Duty cycle

** Lowest cooling power according to IEC 60974-2



**Water-cooled
hosepack - MHP
700d W ML M**

	MHP 700d W ML M
I (ampere) 10 min/40 °C CO ²	100% D.C.* 700
I (ampere) 10 min/40 °C M21	100% D.C.* 560
 [mm (in.)]	0.8-1.6 (0.032-0.063)
 [m (ft.)]	1.35 / 2.35 / 3.35 (4.4 / 7.7 / 14)
P _{min}  [W]**	1100 / 1450 / 1800
Q _{min}  [l/min (gal./ min.)]	1 (.26)
P _{min}  [bar (psi.)]	3 (43)
P _{max}  [bar (psi.)]	5 (72)

* D.C. = Duty cycle

** Lowest cooling power according to IEC 60974-2

MTG 400d K4



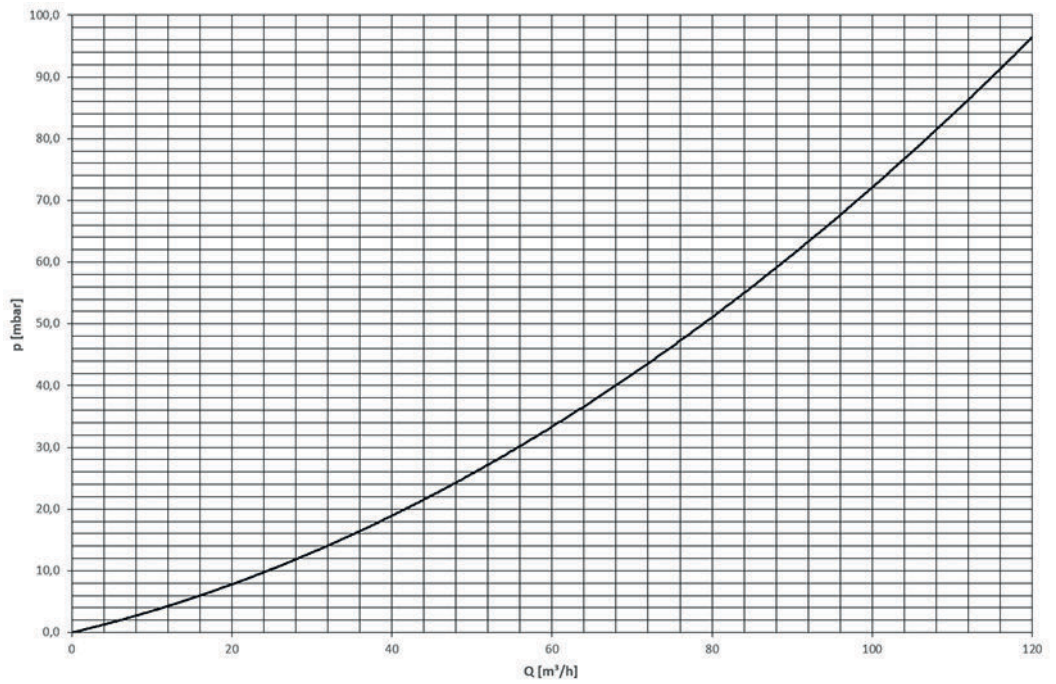

		MTG 400d K4
I (ampere) 10 min/40 °C CO ₂ / mixed		40% D.C.* 400 60% D.C.* 320 100% D.C.* 260
 [mm (in.)]		0.8-1.6 (0.032-0.063)
 [m (ft.)]		4.5 (15)

* D.C. = Duty cycle

**MTG 400d K4
extraction characteristic**

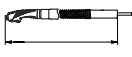

MTW 500d K4

		MTW 500d K4
I (ampere) 10 min/40 °C CO ₂ / mixed		100 % D.C.* 500
 [mm (in.)]		0,8-1,6 (.032-.063)
 [m (ft.)]		4,5 (15)
P _{max}  [W]**		1700
Q _{min}  [l/min (gal./min)]		1 (26)
P _{min}  [bar (psi.)]		3 (43)
P _{max}  [bar (psi.)]		5 (72)

* D.C. = Duty cycle

** Lowest cooling power according to standard IEC 60974-2

**MTW 500d K4
extraction cha-
racteristic**



Tabla de contenido

Seguridad	72
Utilización prevista	72
Seguridad	72
Peligro por humo de soldadura	73
MTG d, MTW d, MHP d - Generalidades	74
Función up/down	74
Función JobMaster	74
MTG 400d K4, MTW 500d K4 - Generalidades	76
Generalidades	76
Valores de orientación para los aparatos de aspiración	76
Regulador de corriente de aire	76
Función up/down	77
Montar los consumibles en el cuello antorcha	78
MTG d, MTW d - Montar los consumibles en el cuello antorcha	78
MTG 400d K4, MTW 500d K4 - Montar los consumibles	78
Montar el cuello antorcha ML en el juego de cables MHP	80
Ensamblar la antorcha de soldadura Multilock	80
Montar las sirgas de guía de hilo	81
Comprobación de las boquillas tensoras	81
Montar la sirga de guía de hilo de acero	82
Montar la sirga de guía de hilo de plástico (F, F++)	83
Montar la sirga de plástico (conexión de Fronius con inyector de guía de hilo)	84
Montar la sirga de guía de hilo de plástico (Euro)	85
Puesta en servicio	86
Conectar la antorcha de soldadura	86
Conectar el sistema de aspiración	86
Girar el cuello antorcha de la antorcha de soldadura Multilock	87
Cambiar el cuello antorcha de la antorcha de soldadura Multilock	88
Soporte de prisma para antorchas de máquina	89
Cuidado y mantenimiento	90
General	90
Detectar consumibles defectuosos	90
Mantenimiento con cada puesta en servicio	90
Mantenimiento con cada sustitución de la bobina de hilo/bobina con fondo de cesta	91
Diagnóstico de errores, solución de errores	93
Diagnóstico de errores, solución de errores	93
Datos técnicos	99
Generalidades	99
Antorcha de soldadura refrigerado por gas - MTG 250d - 500d	99
Cuello antorcha refrigerado por gas - MTB 250i, 320i, 330i, 400i, 550i G ML	99
Juego de cables refrigerado por gas - MHP 400d G ML	100
Juego de cables refrigerado por gas - MHP 500d G ML M	100
Antorcha de soldadura refrigerado por agua - MTW 250d - 700d	100
Cuello antorcha refrigerado por agua - MTB 250i, 330i, 400i, 500i, 700i W ML	101
Juego de cables refrigerado por agua - MHP 500d, 700d W ML	101
Juego de cables refrigerado por agua - MHP 700d W ML M	102
MTG 400d K4	103
Curva característica de aspiración MTG 400d K4	103
MTW 500d K4	104
Curva característica de aspiración MTW 500d K4	104

Seguridad

Utilización prevista

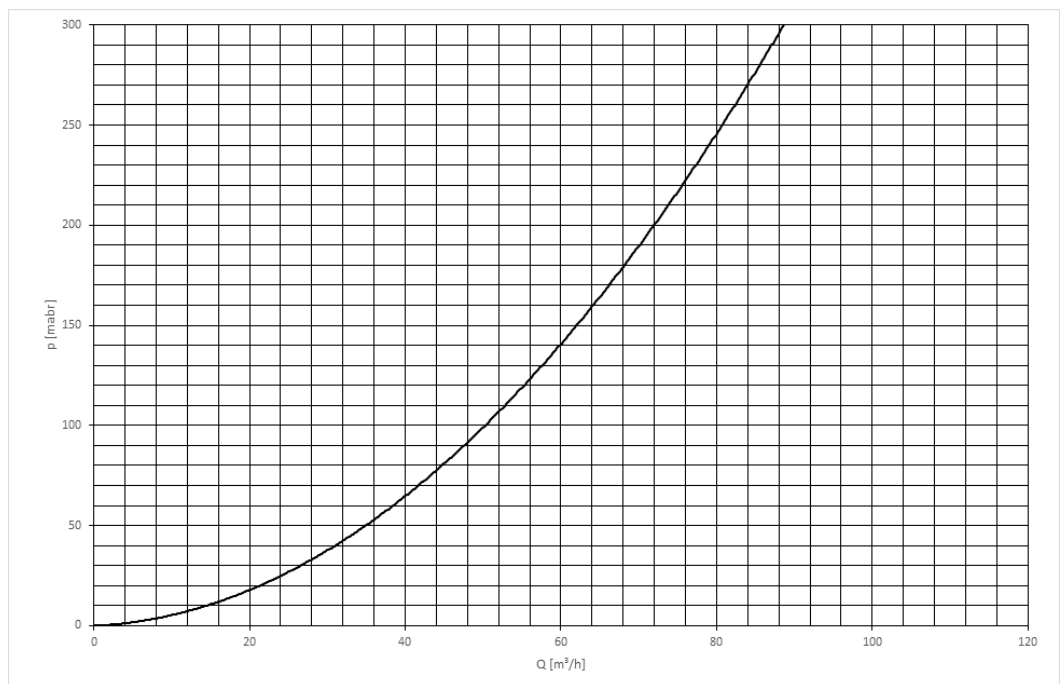
La antorcha manual MIG/MAG está diseñada exclusivamente para la soldadura MIG/MAG en aplicaciones manuales. Cualquier otro uso se considerará como no previsto por el diseño constructivo. El fabricante declina cualquier responsabilidad frente a los daños que se pudieran originar.

También forman parte de la utilización prevista

- Seguir todas las indicaciones del manual de instrucciones.
 - El cumplimiento de los trabajos de inspección y mantenimiento.
-

Seguridad

¡PELIGRO!

Peligro originado por un manejo incorrecto y trabajos realizados incorrectamente.

La consecuencia pueden ser graves daños personales y materiales.

- ▶ Todos los trabajos y funciones descritos en este documento deben ser realizados solo por personal técnico formado.
 - ▶ Leer y comprender por completo este documento.
 - ▶ Leer y comprender todas las normas de seguridad y documentaciones para el usuario de este equipo y los componentes del sistema.
-

¡PELIGRO!

Peligro originado por corriente eléctrica.

La consecuencia pueden ser graves daños personales y materiales.

- ▶ Se deben apagar y separar de la red de corriente todos los equipos y componentes antes de comenzar los trabajos.
 - ▶ Asegurar todos los equipos y componentes contra cualquier reconexión.
-

¡PELIGRO!

Peligro originado por corriente eléctrica debido a componentes del sistema defectuosos y a un funcionamiento incorrecto.

La consecuencia pueden ser graves daños personales y materiales.

- ▶ Todos los cables, líneas y juegos de cables siempre deben estar bien conectados, intactos y correctamente aislados.
 - ▶ Utilizar únicamente cables, conductos y juegos de cables con las dimensiones adecuadas.
-

¡PELIGRO!

Peligro de tropiezo debido a la fuga de líquido de refrigeración.

La consecuencia pueden ser graves daños personales y materiales.

- ▶ Cerrar siempre los tubos de líquido de refrigeración de las antorchas de soldadura refrigeradas por agua con el cierre de plástico montado cuando se separan de la refrigeración o de otros componentes del sistema.
-

 **¡PELIGRO!**

Peligro originado por componentes del sistema o medios de servicio calientes.

Pueden producirse quemaduras y escaldaduras graves.

- ▶ Antes de comenzar los trabajos, dejar que todos los componentes del sistema o medios de funcionamiento calientes se enfríen a +25 °C / +77 °F (por ejemplo, el líquido de refrigeración, los componentes del sistema refrigerados por agua, el motor de accionamiento del avance de hilo, etc).
- ▶ De no ser posible, utilizar equipo de protección adecuado (por ejemplo, guantes de protección termorresistentes, gafas de seguridad, etc.).

 **¡PELIGRO!**

Peligro por contacto con humo de soldadura tóxico.

Esto puede ocasionar lesiones graves.

- ▶ Extraer siempre el humo de soldadura.
- ▶ Procurar que haya suficiente alimentación de aire fresco. Garantizar como mínimo una tasa de ventilación de 20 m³/hora (169070.1 US gi) en todo momento.
- ▶ En caso de duda, encargar a un técnico de seguridad que compruebe la concentración de sustancias nocivas en el puesto de trabajo.

 **¡PRECAUCIÓN!**

Peligro al operar sin líquido de refrigeración.

Pueden producirse daños materiales.

- ▶ Jamás se deben poner en servicio equipos refrigerados por agua sin líquido de refrigeración.
- ▶ Durante la soldadura, se debe asegurar de que haya un caudal líquido de refrigeración adecuado. En una refrigeración de Fronius, será adecuado si el retorno de líquido de refrigeración es visible en el depósito de la refrigeración.
- ▶ El fabricante no se responsabiliza de los daños derivados del incumplimiento de los puntos anteriores, en cuyo caso se extinguirán todos los derechos de garantía.

Peligro por humo de soldadura

 **¡PELIGRO!**

Peligro por el humo que se genera durante la soldadura, que contiene gases y vapores dañinos para la salud.

Esto puede ocasionar graves perjuicios para la salud.

- ▶ No está permitido el servicio sin un aparato de aspiración conectado.
- ▶ En algunas circunstancias, el mero uso de una antorcha de aspiración no es suficiente.
En este caso deberá instalarse un sistema de aspiración adicional para reducir las sustancias nocivas en el puesto de trabajo.
- ▶ En caso de duda, encargue a un técnico de seguridad que compruebe la concentración de sustancias nocivas en el puesto de trabajo.

MTG d, MTW d, MHP d - Generalidades

Función up/down

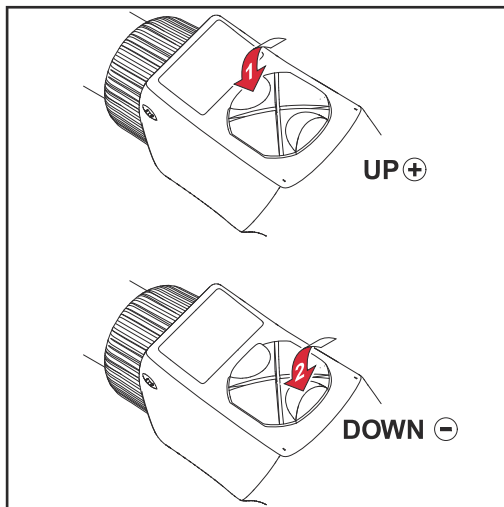

- Seleccionar uno de los siguientes parámetros en la fuente de corriente:
 - Velocidad de hilo
 - Número de Job
- Ajustar el parámetro con la función up/down

¡IMPORTANTE! En los modos de operación "Soldadura MIG/MAG sinérgica estándar y Puls-Synergic" se pueden ajustar otros parámetros adicionales.

Función JobMaster

¡IMPORTANTE! En el JobMaster pueden aparecer mensajes codificados que se corresponden con el código de servicio mostrado simultáneamente en el panel de control (ver el manual de instrucciones de la fuente de corriente, capítulo "Diagnóstico y solución de errores").

SynchroPuls (opción): no se ilumina ningún símbolo en el JobMaster (ver el manual de instrucciones de la fuente de corriente, capítulo "Soldadura MIG/MAG").

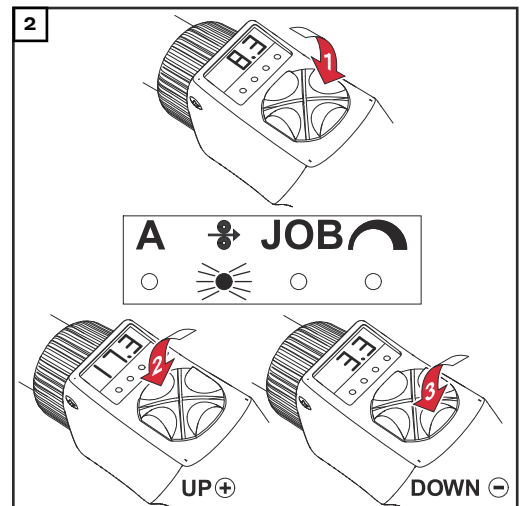
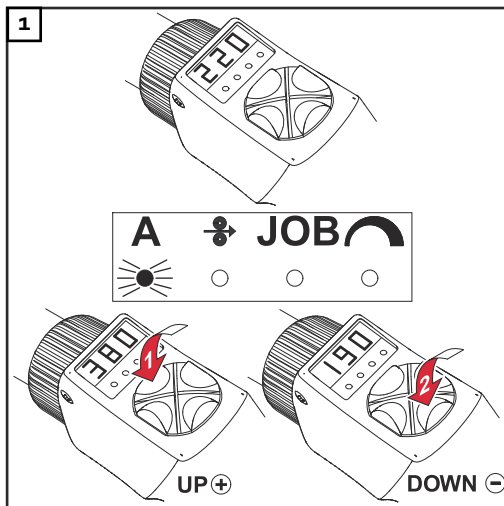

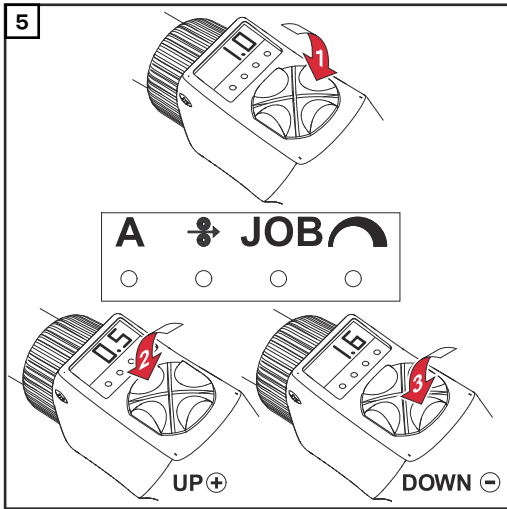
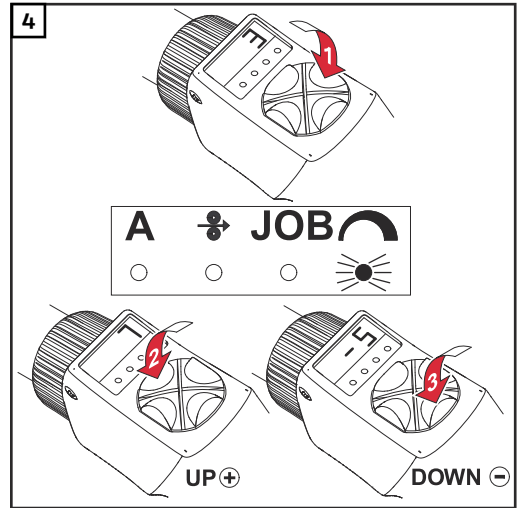
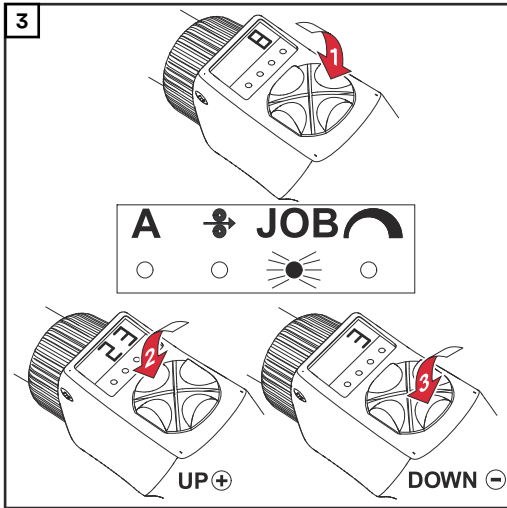

MTG 400d K4, MTW 500d K4 - Generalidades

Generalidades

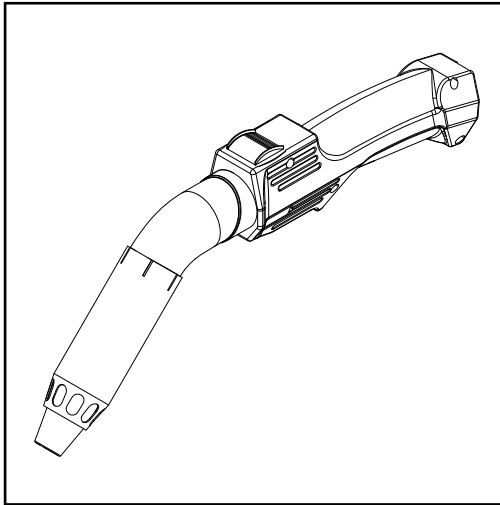

Las antorchas de aspiración MTG 400d K4 y MTW 500d K4 captan el humo perjudicial que se genera durante la soldadura directamente en su origen. El humo de soldadura se aspira antes de que alcance la zona de respiración del soldador. Deben respetarse los valores máximos de concentración prescritos en el puesto de trabajo ("MAK").

Valores de orientación para los aparatos de aspiración

El aparato de aspiración para la antorcha de aspiración debe cumplir los siguientes requisitos:

Potencia de aspiración	aprox. 100 m ³ /h
Valores de depresión	entre 0,05 y 0,2 bar (entre 5000 y 20000 Pa)

Regulador de corriente de aire

Con el regulador de corriente de aire se puede regular de forma continua la cantidad aspirada de humo de soldadura durante el proceso entre el 10 y el 100 %.

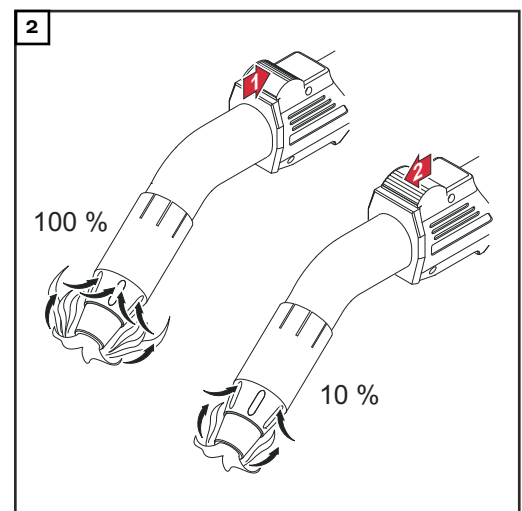
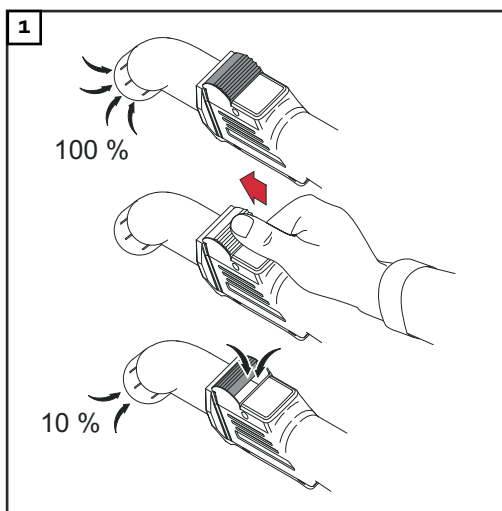

¡IMPORTANTE! Es necesario regular la cantidad aspirada de humo de soldadura si el gas protector se aspira junto con el mismo (p. ej. al soldar esquinas).

**Función up/
down**

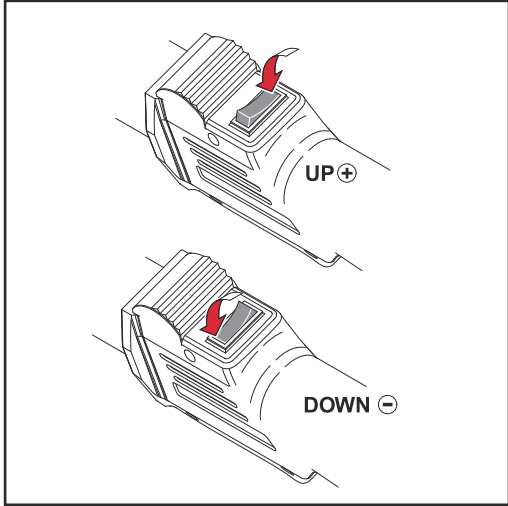

Montar los consumibles en el cuello antorcha

MTG d, MTW d -
Montar los consumibles en el
cuello antorcha

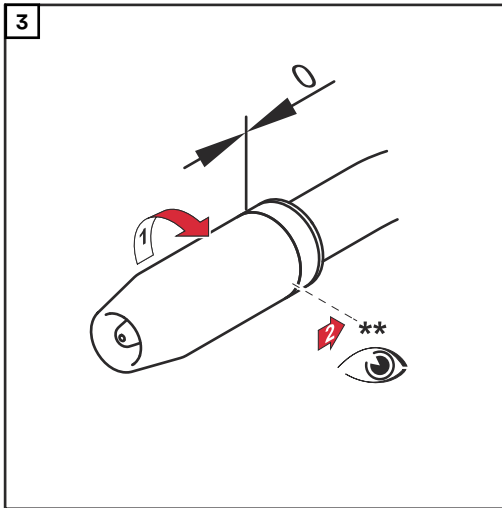
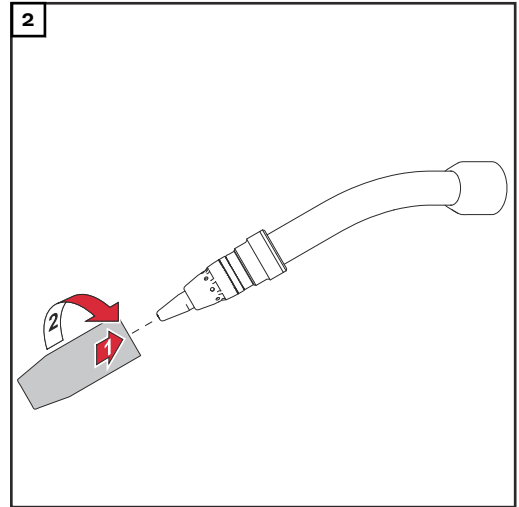
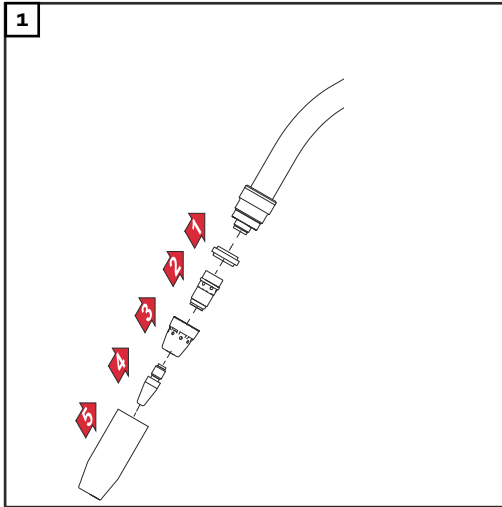

** Apretar la tobera de gas hasta el tope

MTG 400d K4,
MTW 500d K4 -
Montar los consumibles

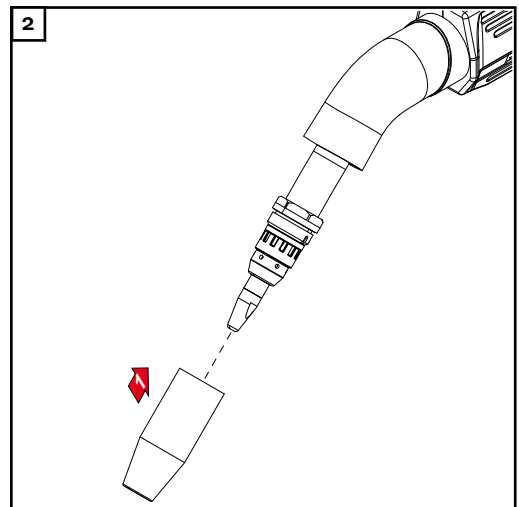
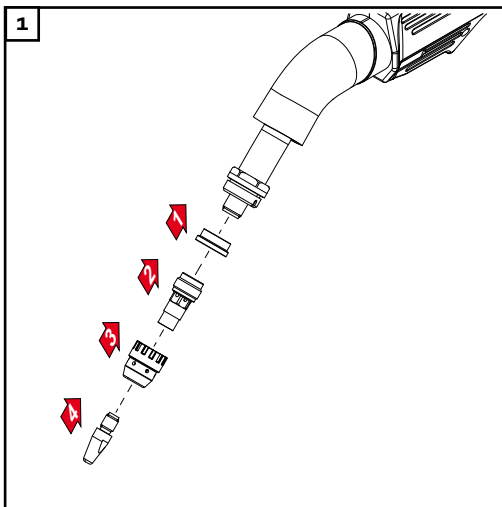

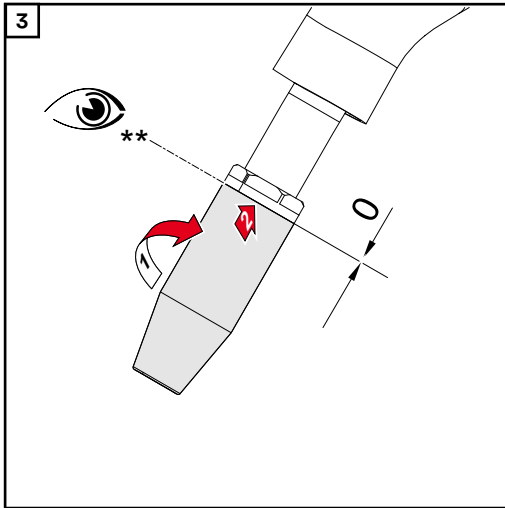

** Apretar la tobera de gas hasta el tope

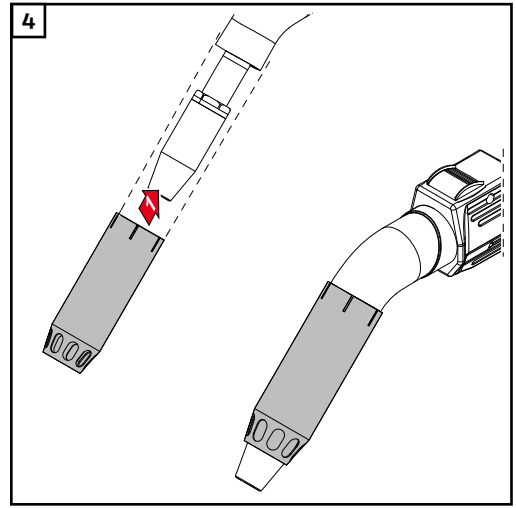

Encajar el inyector de aspiración

Montar el cuello antorcha ML en el juego de cables MHP

Ensamblar la antorcha de soldadura Multi-lock

¡OBSERVACIÓN!

Peligro de dañar la antorcha de soldadura. Apretar el racor del cuello antorcha siempre hasta el tope.

¡OBSERVACIÓN!

Debido al diseño de las antorchas refrigeradas por agua, al apretar el racor puede aumentar la resistencia. Esto es normal. Apretar el racor del cuello antorcha siempre hasta el tope.

¡OBSERVACIÓN!

Antes de montar un cuello antorcha, asegurarse de que el punto de acoplamiento del cuello antorcha y del juego de cables esté intacto y limpio.

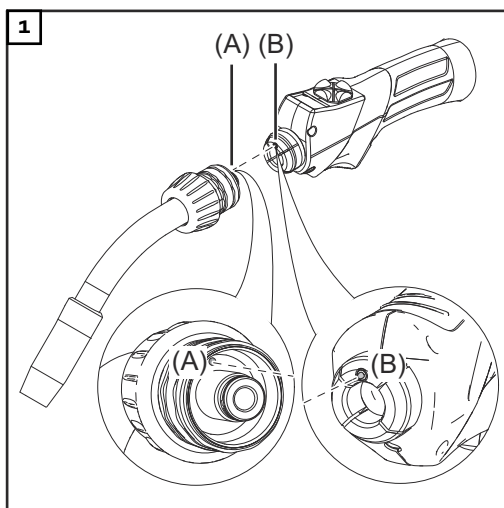

¡OBSERVACIÓN!

Cuando el pasador de ajuste (A) del juego de cables encaja en el taladro de ajuste (B) del cuello antorcha, el cuello antorcha se encuentra en la posición de 0°.

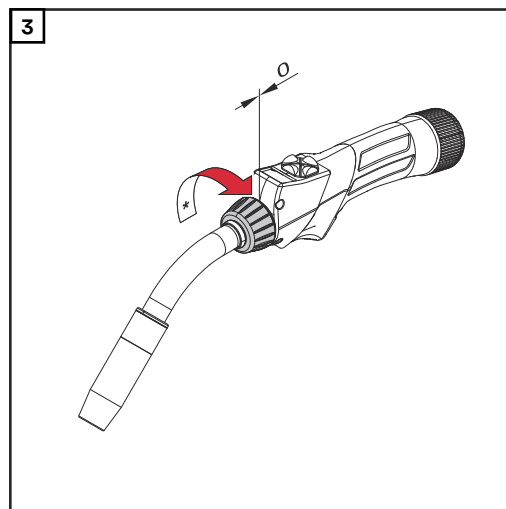
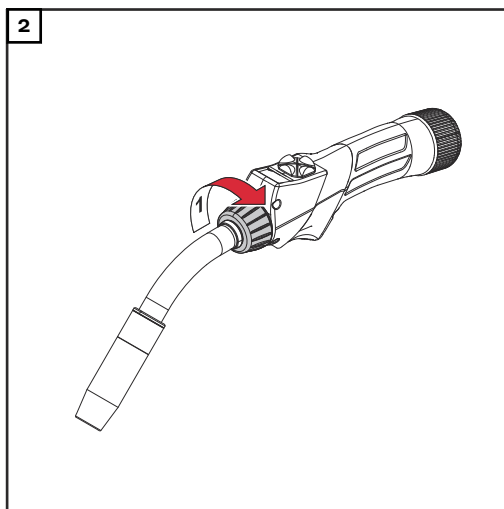

* Asegurarse de que el racor esté apretado hasta el tope.

Montar las sirgas de guía de hilo

Comprobación de las boquillas tensoras

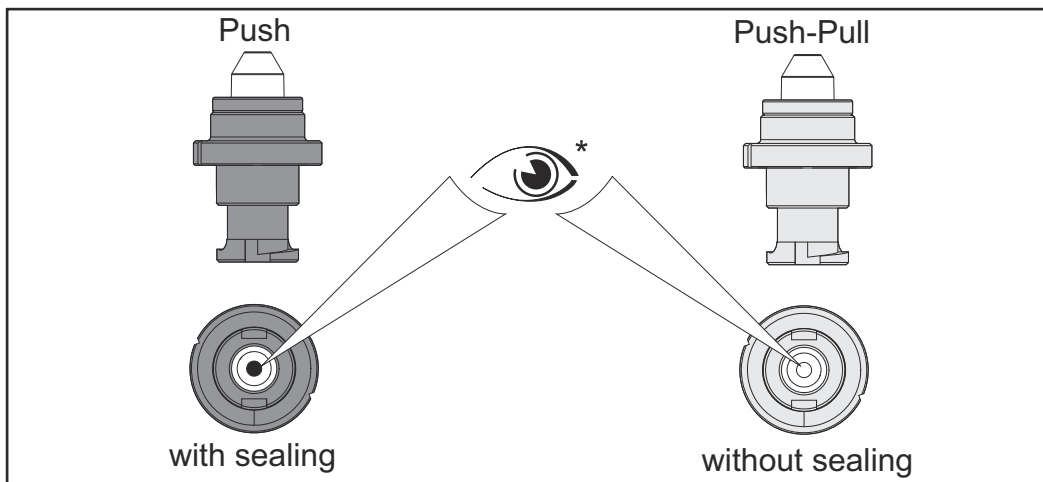

- * Comprobar la boquilla tensora antes de la puesta en marcha y cada vez que se cambie la sirga de guía de hilo. Realizar una comprobación visual:
- Izquierda: boquilla tensora de latón con arandela aislante. No se puede ver a través de la arandela aislante.
 - Derecha: boquilla tensora plateada con orificio visible.

¡OBSERVACIÓN!

Boquilla tensora incorrecta o defectuosa en aplicaciones Push.

Esto tiene como consecuencia la pérdida de gas y propiedades insuficientes de soldadura.

- ▶ Utilizar boquillas de sujeción de latón para minimizar la pérdida de gas.
- ▶ Comprobar que la arandela aislante está intacta.

¡OBSERVACIÓN!

Boquilla tensora incorrecta en aplicaciones Push-Pull.

Hilo enredado y aumento de la abrasión en la sirga de guía de hilo cuando se utiliza una boquilla tensora con arandela aislante.

- ▶ Utilizar una boquilla tensora plateada para facilitar la guía de hilo.

Montar la sirga de guía de hilo de acero

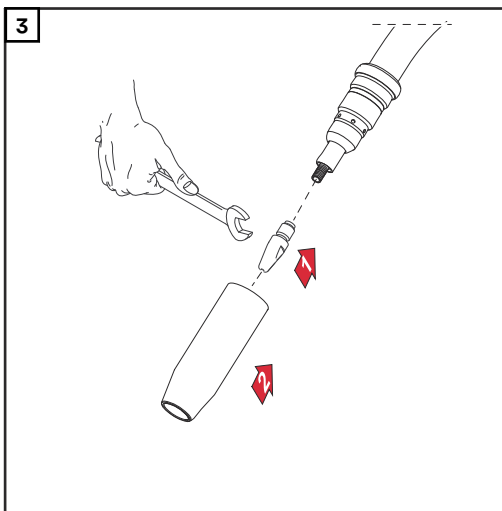
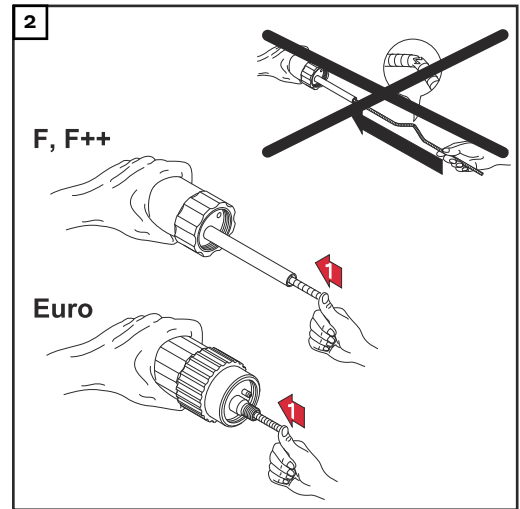
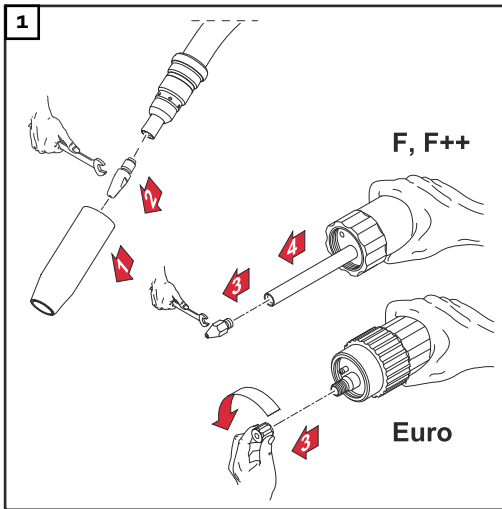

F++, F:

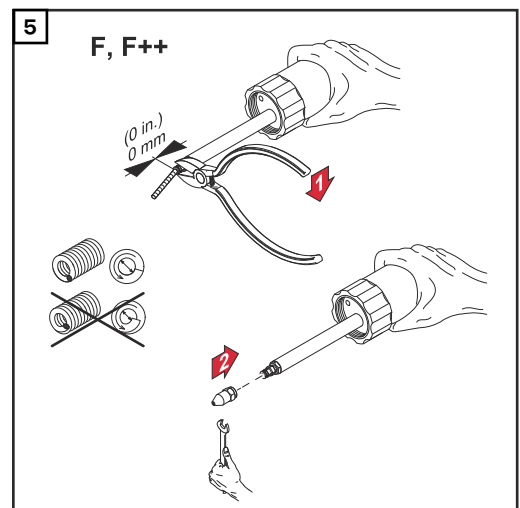
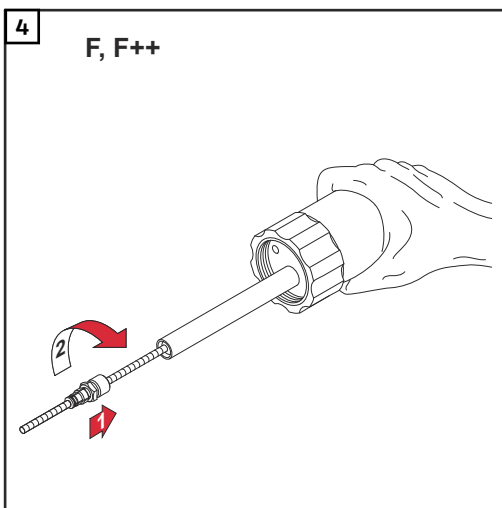

Euro:

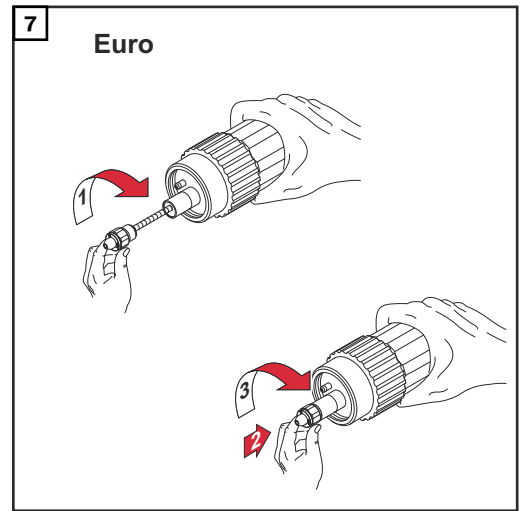
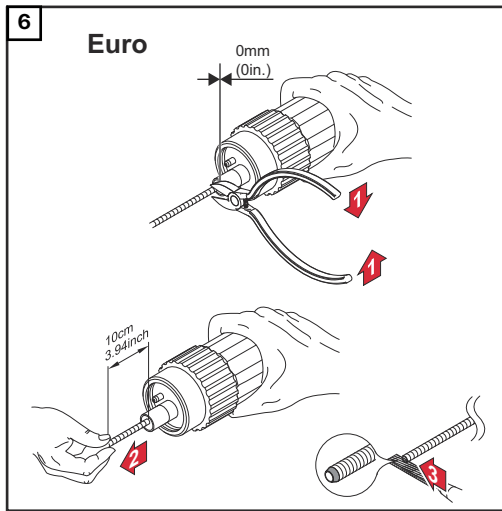

Montar la sirga de guía de hilo de plástico (F, F++)

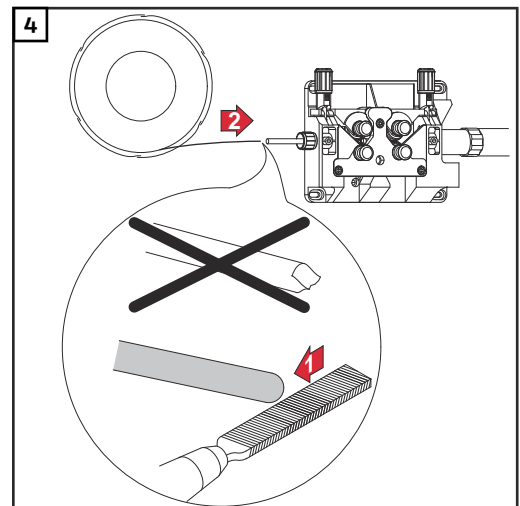
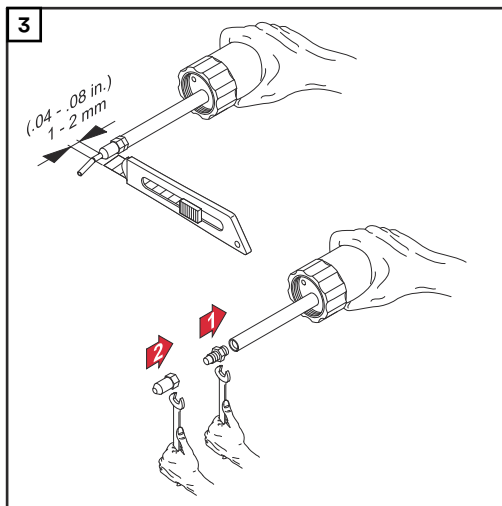
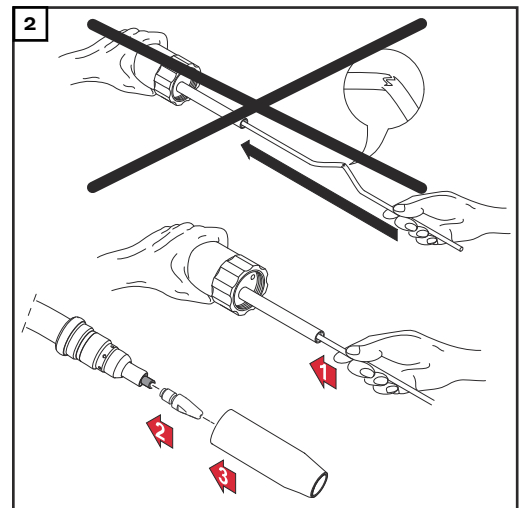
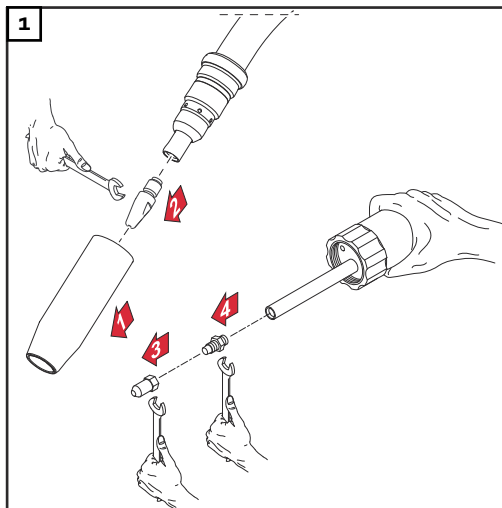

Montar la sirga de plástico (conexión de Fronius con inyector de guía de hilo)

¡OBSERVACIÓN!

Redondear el extremo del electrodo de soldadura antes de enhebrarlo.

Esto es aplicable a sirgas de teflón, sirgas combi y sirgas de grafito.

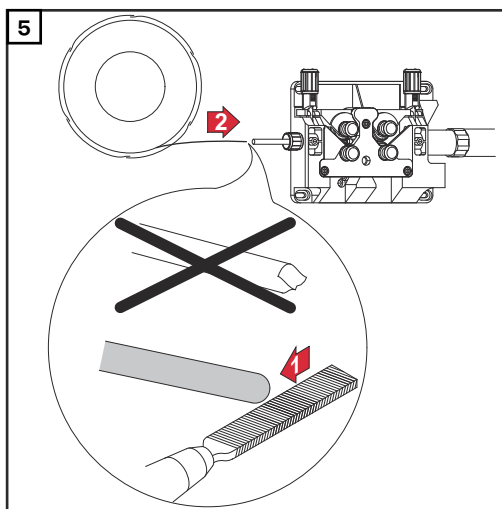
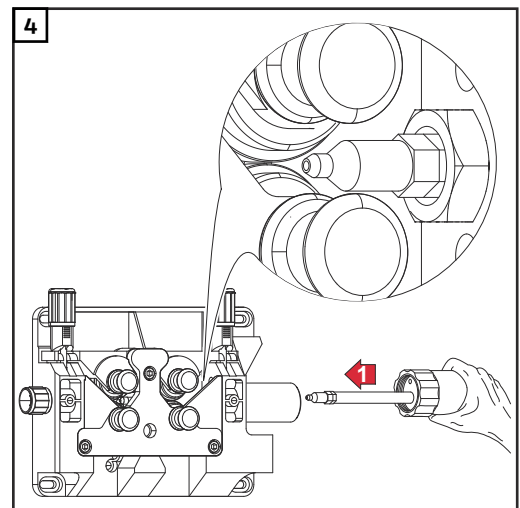
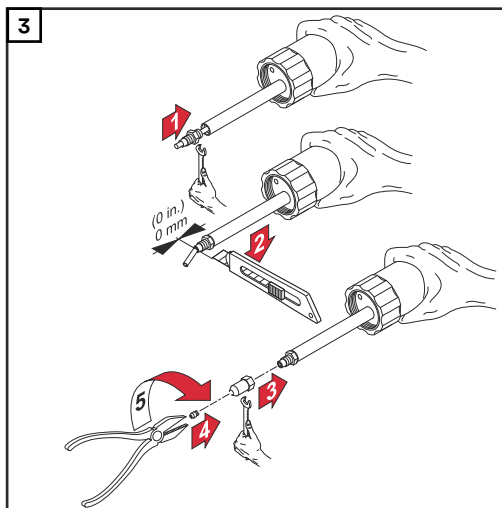
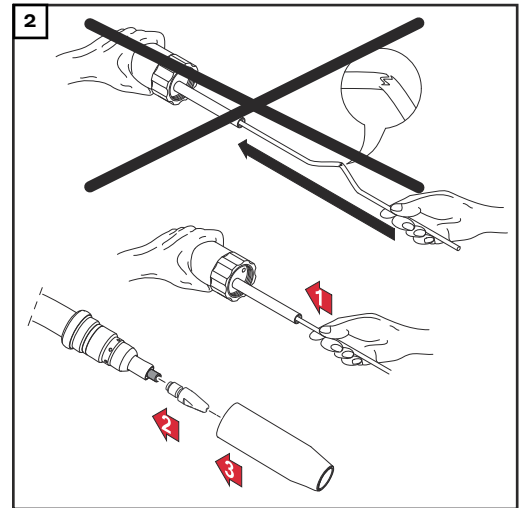
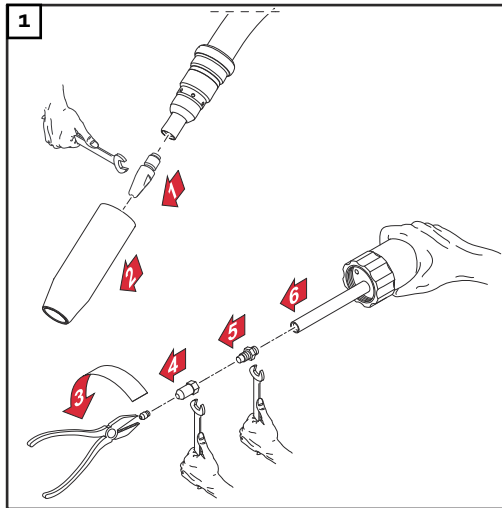

Montar la sirga de guía de hilo de plástico (Euro)

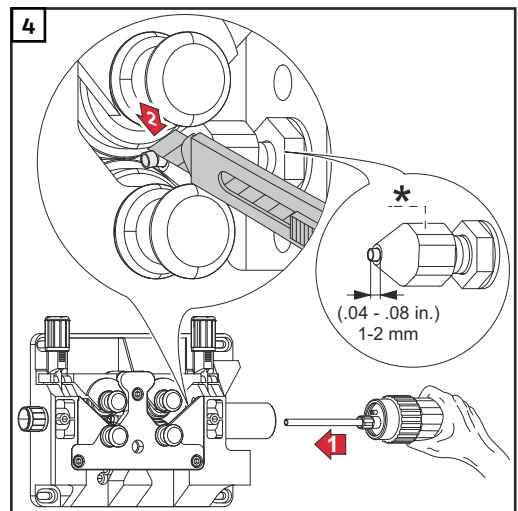
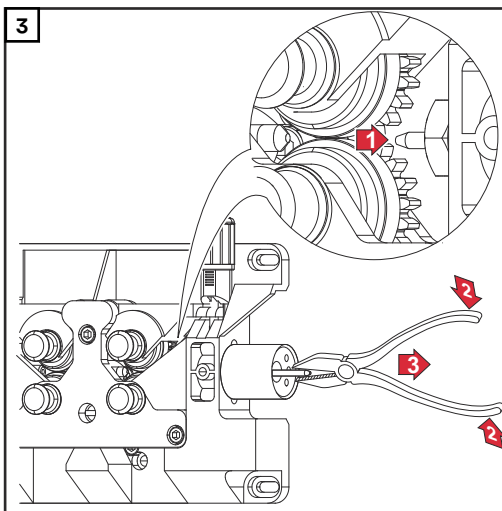
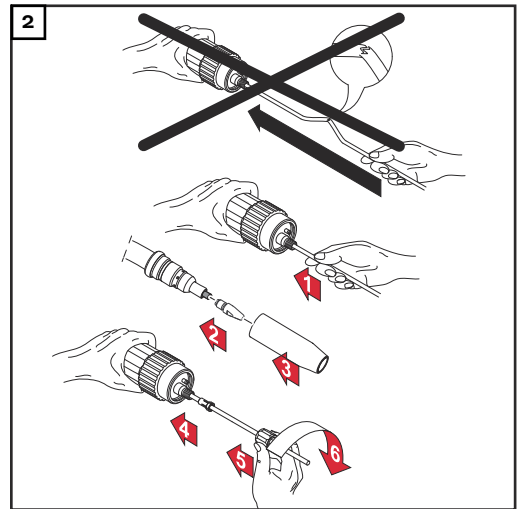
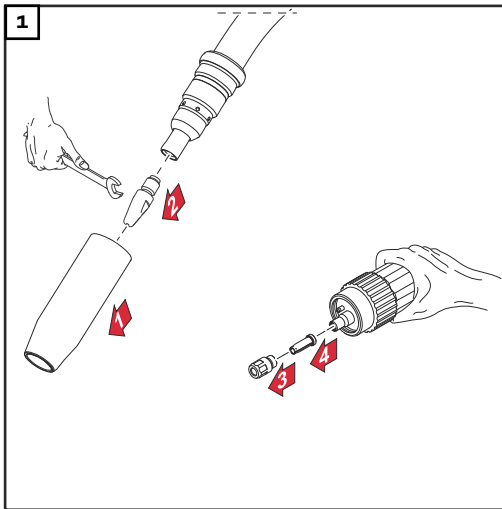

* Opción boca de carga (42,0001,5421)

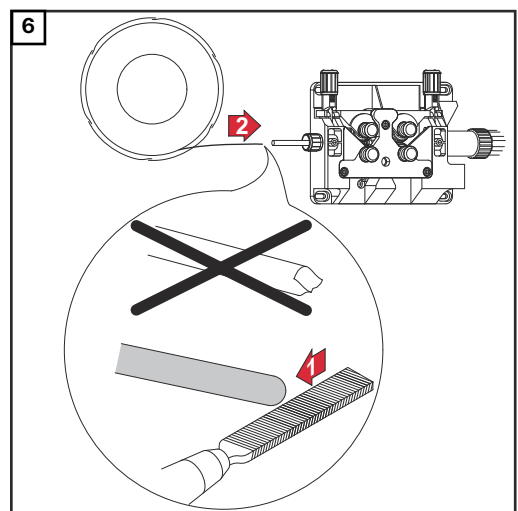
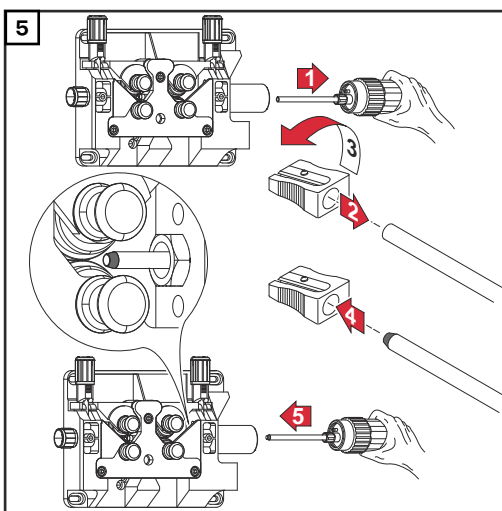

Puesta en servicio

Conectar la antorcha de soldadura

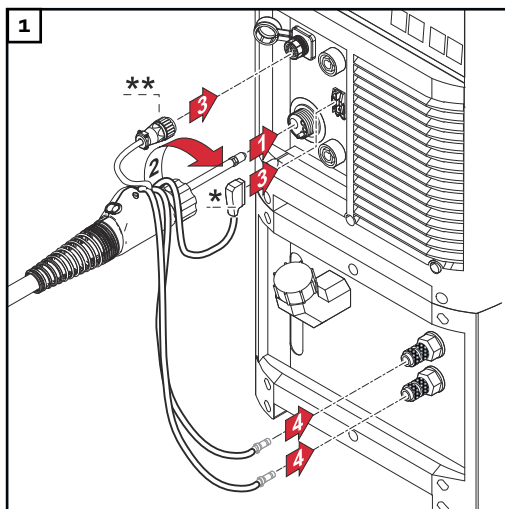

- * Conector LocalNet (antorcha de soldadura estándar o up/down)
- ** Conector JobMaster (antorcha de soldadura JobMaster)

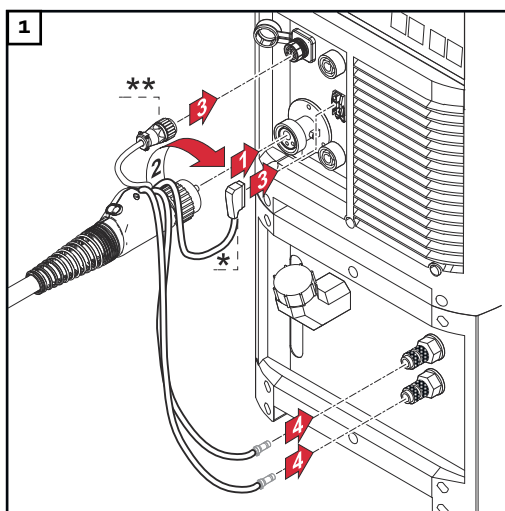

- * Conector LocalNet (antorcha de soldadura estándar o up/down)
- ** Conector JobMaster (antorcha de soldadura JobMaster)

Conectar el sistema de aspiración

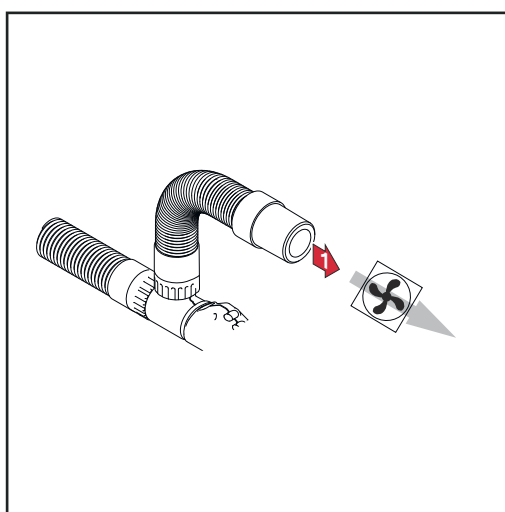

- 1 Conectar el tubo de aspiración conforme a los valores de orientación para aparatos de aspiración

Girar el cuello antorcha de la antorcha de soldadura Multi-lock

⚠ ¡PRECAUCIÓN!

Peligro de quemaduras por estar calientes el líquido de refrigeración y el cuello antorcha.

- ▶ Antes de comenzar los trabajos, dejar que se enfríen el líquido de refrigeración y el cuello antorcha a temperatura ambiente (+25 °C, +77 °F).

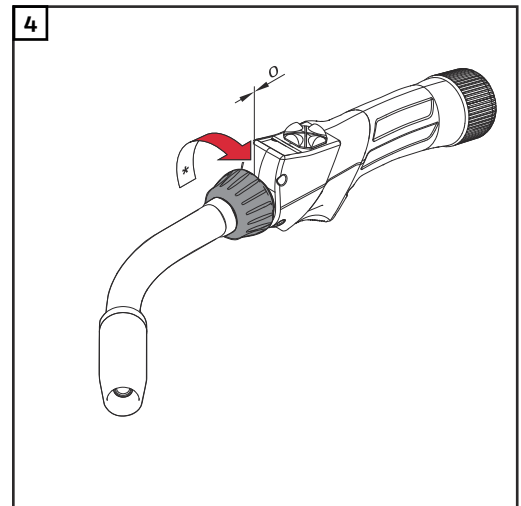
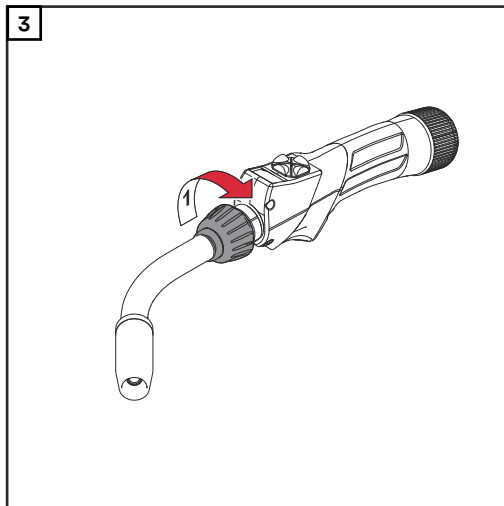
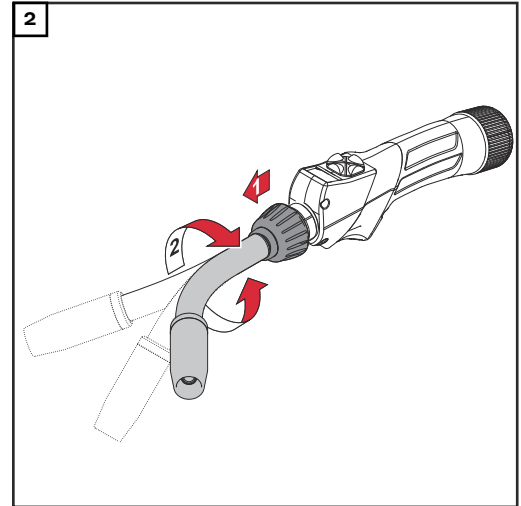
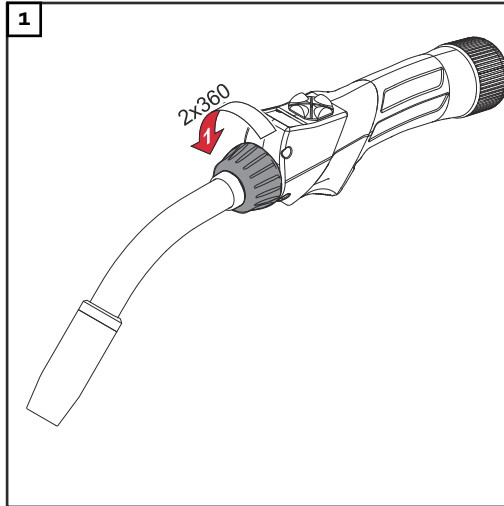

* Asegurarse de que el racor esté apretado hasta el tope.

Cambiar el cuello antorcha de la antorcha de soldadura Multi-lock

⚠ ¡PRECAUCIÓN!

Peligro de quemaduras por estar calientes el líquido de refrigeración y el cuello antorcha.

La consecuencia pueden ser escaldaduras graves.

- ▶ Antes de comenzar los trabajos, dejar que se enfríen el líquido de refrigeración y el cuello antorcha a temperatura ambiente (+25 °C, +77 °F).

¡OBSERVACIÓN!

En el cuello antorcha siempre hay restos de líquido de refrigeración.

Desmontar el cuello antorcha solo cuando la tobera de gas esté apuntando hacia abajo.

¡OBSERVACIÓN!

Antes de montar un cuello antorcha, asegurarse de que el punto de acoplamiento del cuello antorcha y del juego de cables esté intacto y limpio.

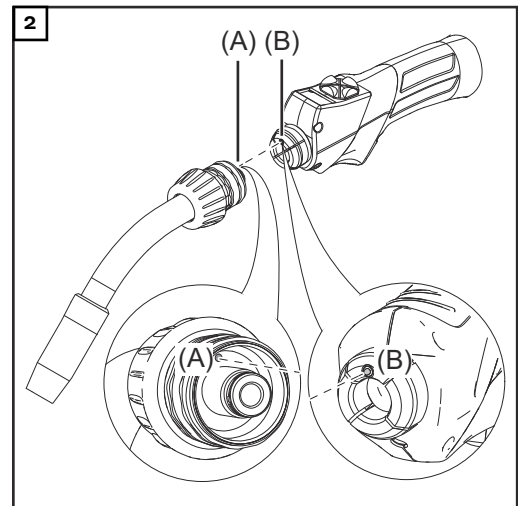
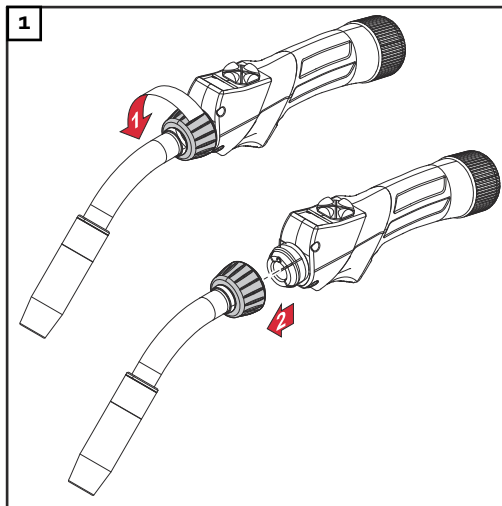

¡OBSERVACIÓN!

Cuando el pasador de ajuste (A) del juego de cables encaja en el taladro de ajuste (B) del cuello antorcha, el cuello antorcha se encuentra en la posición de 0°.

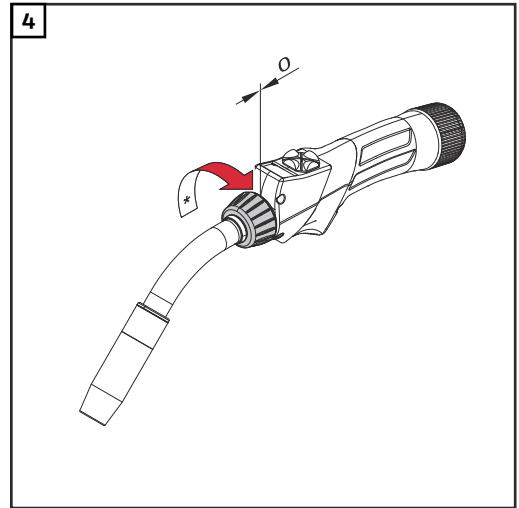
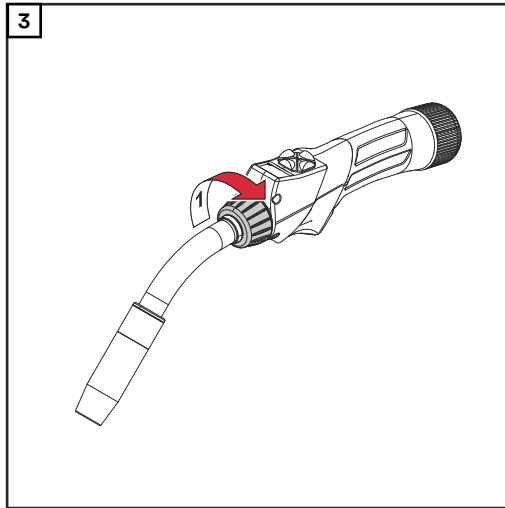

* Asegurarse de que el racor esté apretado hasta el tope.

Soporte de prisma para antorchas de máquina

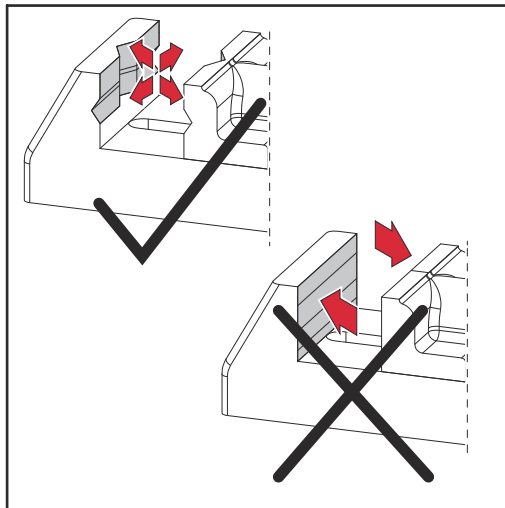

¡Fijar la antorcha de máquina para el mecanizado únicamente en un soporte de prisma adecuado!

Cuidado y mantenimiento

General

El mantenimiento periódico y preventivo de la antorcha de soldadura es un factor relevante para un servicio sin perturbaciones. La antorcha de soldadura está expuesta a altas temperaturas y a una intensa suciedad. Por este motivo, la antorcha de soldadura requiere un mantenimiento más frecuente que los demás componentes del sistema de soldadura.

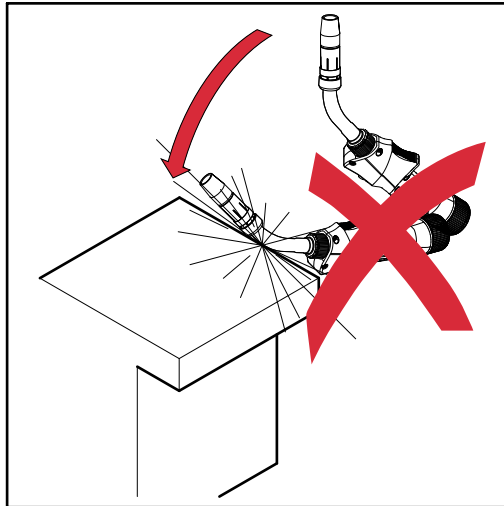

¡PRECAUCIÓN!

El manejo indebido de la antorcha de soldadura implica riesgo de daños.

Pueden producirse daños materiales graves.

- ▶ No golpear la antorcha de soldadura contra objetos duros.
- ▶ Evitar las rayas y los arañazos en el tubo de contacto.
- ▶ En ningún caso se debe doblar el cuello antorcha.

Detectar consumibles defectuosos

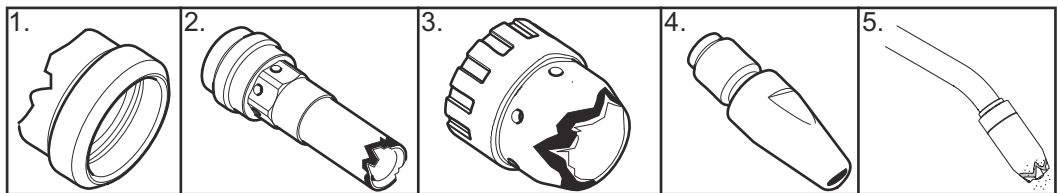

1. Piezas aislantes
 - Bordes exteriores quemados, entalladuras
2. Porta tubos
 - Bordes exteriores quemados, entalladuras
 - Pronunciada adhesión de proyecciones de soldadura
3. Protección antiproyecciones
 - Bordes exteriores quemados, entalladuras
4. Tubos de contacto
 - Taladros de entrada y salida de hilo desgastados (ovalados)
 - Pronunciada adhesión de proyecciones de soldadura
 - Penetración en la punta del tubo de contacto
5. Toberas de gas
 - Pronunciada adhesión de proyecciones de soldadura
 - Bordes exteriores quemados
 - entalladuras.

Mantenimiento con cada puesta en servicio

- Controlar los consumibles
- Sustituir los consumibles defectuosos
- Alejar la tobera de gas de las proyecciones de soldadura

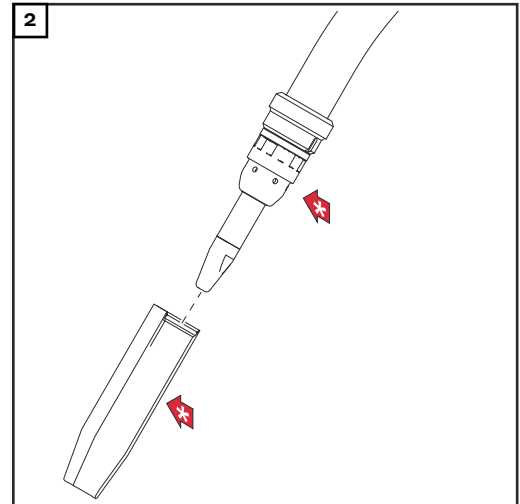
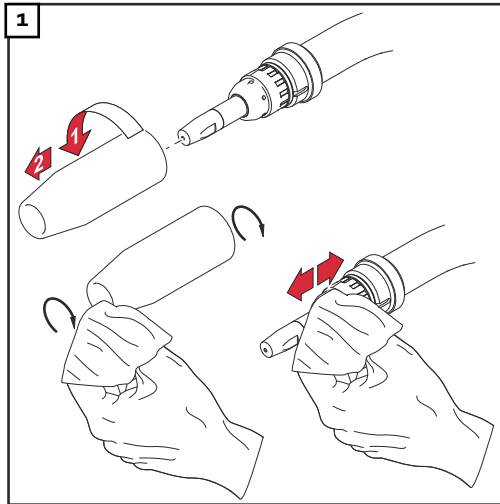

- * Comprobar la tobera de gas, la protección antiproyecciones y los aislamientos con respecto a daños y sustituir los componentes dañados.
- Adicionalmente con cada puesta en servicio, en caso de antorchas refrigeradas por agua:
 - Asegurarse de que todas las conexiones de líquido de refrigeración están estancas
 - Asegurarse de que el retorno de líquido de refrigeración está limitado correctamente

Mantenimiento con cada sustitución de la bobina de hilo/bobina con fondo de cesta

- Limpiar la manguera de transporte de hilo con aire a presión reducido
- Recomendado: Sustituir la sirga de guía de hilo; antes de volver a montar la sirga de guía de hilo limpiar los consumibles.

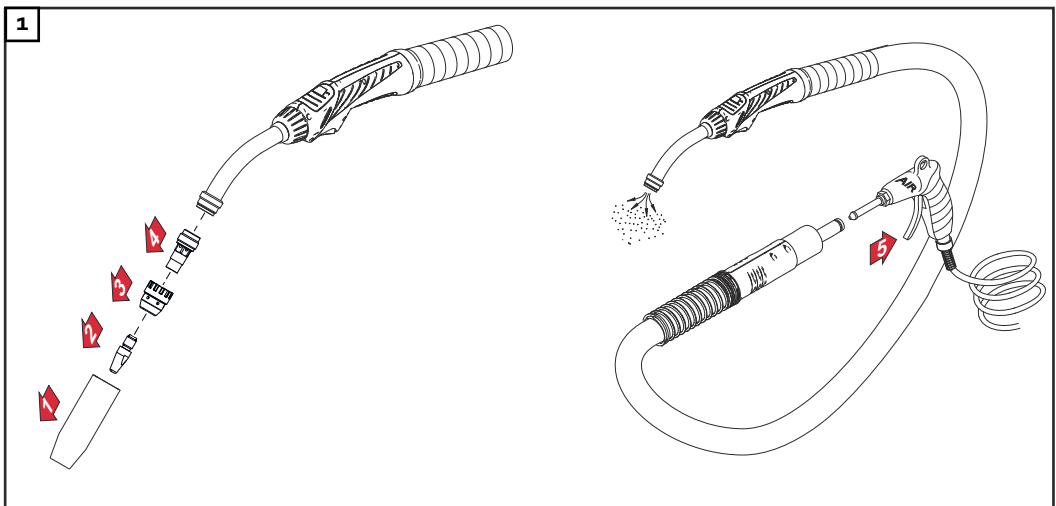

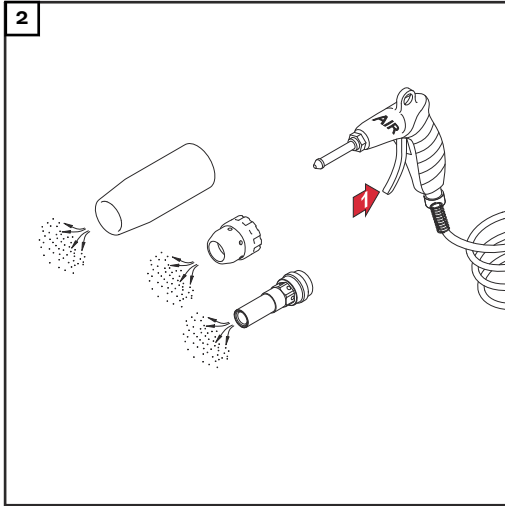

Diagnóstico de errores, solución de errores

Diagnóstico de errores, solución de errores

No hay corriente de soldadura

Interruptor de red de la fuente de corriente conectado, indicaciones en la fuente de corriente iluminadas, gas protector disponible.

Causa: Conexión de masa errónea.

Solución: Establecer la conexión de masa correctamente.

Causa: Cable de corriente interrumpido en la antorcha de soldadura.

Solución: Sustituir la antorcha de soldadura.

No hay función después de pulsar la tecla de la antorcha

Interruptor de red de la fuente de corriente conectado, indicaciones en la fuente de corriente iluminadas.

Causa: La FSC ("Fronius System Connector" - conexión central) no está enchufada hasta el tope.

Solución: Enchufar la FSC hasta el tope.

Causa: Antorcha de soldadura o cable de control de la antorcha de soldadura defectuoso.

Solución: Sustituir la antorcha de soldadura.

Causa: El juego de cables de interconexión no está correctamente conectado o está defectuoso.

Solución: Conectar el juego de cables de interconexión correctamente. Sustituir el juego de cables de interconexión defectuoso.

Causa: Fuente de corriente defectuosa.

Solución: Contactar con el Servicio Técnico.

No hay gas protector

Todas las demás funciones están disponibles.

Causa: Bombona de gas vacía.

Solución: Cambiar la bombona de gas.

Causa: Regulador de presión de gas defectuoso.

Solución: Sustituir el regulador de presión de gas.

Causa: Manguera de gas doblada, dañada o no montada.

Solución: Montar la manguera de gas, tenderla recta. Sustituir la manguera de gas defectuosa.

Causa: Antorcha de soldadura defectuosa.

Solución: Sustituir la antorcha de soldadura.

Causa: Electroválvula de gas defectuosa.

Solución: Contactar con el Servicio Técnico (encomendar la sustitución de la electroválvula de gas).

Propiedades insuficientes de soldadura.

Causa: Parámetros de soldadura incorrectos.

Solución: Corregir los ajustes.

Causa: Pinza de masa incorrecta

Solución: Establecer un buen contacto con la pieza de trabajo.

Causa: No hay gas protector o el gas es insuficiente.

Solución: Comprobar el regulador de presión, el tubo de gas, la electroválvula de gas y la conexión de gas de la antorcha de soldadura. En caso de antorchas refrigeradas por gas, se debe comprobar la obturación de gas; utilizar una sirga de guía de hilo adecuada.

Causa: Fuga en la antorcha de soldadura

Solución: Sustituir la antorcha de soldadura.

Causa: Tubo de contacto excesivamente grande o desgastado.

Solución: Cambiar el tubo de contacto.

Causa: Aleación incorrecta del hilo o diámetro de hilo incorrecto.

Solución: Comprobar la bobina de hilo/porta bobina

Causa: Aleación incorrecta del hilo o diámetro de hilo incorrecto.

Solución: Comprobar la soldabilidad del material base.

Causa: El gas protector no es adecuado para la aleación del hilo.

Solución: Utilizar el gas protector correcto.

Causa: Condiciones de soldadura desfavorables: gas protector sucio (humedad, aire), insuficiente blindado de gas (el baño de fusión está "hirviendo", corriente), impurezas en la pieza de trabajo (corrosión, pintura, grasa).

Solución: Optimizar las condiciones de soldadura.

Causa: El gas protector se escapa de las boquillas tensoras.

Solución: Utilizar las boquillas tensoras correctas.

Causa: La arandela aislante de la boquilla tensora es defectuosa, el gas protector se escapa de la boquilla tensora.

Solución: Sustituir las boquillas tensoras para garantizar la estanqueidad.

Causa: Proyecciones de soldadura en la tobera de gas.

Solución: Quitar las proyecciones de soldadura.

Causa: Turbulencias originadas por una cantidad excesiva de gas protector.

Solución: Reducir la cantidad de gas protector, recomendación:
cantidad de gas protector (l/min) = diámetro del hilo (mm) x 10
(por ejemplo, 16 l/min para un electrodo de soldadura de 1,6 mm).

Causa: Distancia excesivamente grande entre la antorcha de soldadura y la pieza de trabajo.

Solución: Reducir la distancia entre la antorcha de soldadura y la pieza de trabajo (aprox. 10 - 15 mm / 0.39 - 0.59 in.).

Causa: El ángulo de incidencia de la antorcha de soldadura es excesivamente grande.

Solución: Reducir el ángulo de incidencia de la antorcha de soldadura.

Causa: Los componentes de transporte de hilo no son adecuados para el diámetro/material del electrodo de soldadura.

Solución: Utilizar unos componentes de transporte de hilo correctos.

Mala alimentación hilo

Causa: Según el sistema, el freno en el avance de hilo o en la fuente de potencia está ajustado demasiado fuerte.

Solución: Aflojar el ajuste del freno.

Causa: Taladro del tubo de contacto incorrecto.

Solución: Sustituir el tubo de contacto.

Causa: La sirga de guía de hilo o el inserto de guía de hilo están defectuosos.

Solución: Comprobar la sirga de guía de hilo o el inserto de guía de hilo respecto a dobladuras, suciedad, etc.
Sustituir la sirga de guía de hilo defectuosa o el inserto de guía de hilo defectuoso.

Causa: Los rodillos de avance no son adecuados para el electrodo de soldadura utilizado.

Solución: Utilizar los rodillos de avance adecuados.

Causa: Presión de contacto incorrecta de los rodillos de avance.

Solución: Mejorar la presión de contacto.

Causa: Los rodillos de avance están sucios o dañados.

Solución: Limpiar o sustituir los rodillos de avance.

Causa: Sirga de guía de hilo mal instalada o doblada.

Solución: Sustituir la sirga de guía de hilo.

Causa: La sirga de guía de hilo es demasiado corta después del tronzado.

Solución: Sustituir la sirga de guía de hilo y acortar la nueva sirga de guía de hilo a la longitud correcta.

Causa: Abrasión del electrodo de soldadura debido a una presión de contacto excesiva en los rodillos de avance.

Solución: Reducir la presión de contacto en los rodillos de avance.

Causa: El electrodo de soldadura está sucio u oxidado.

Solución: Utilizar un electrodo de soldadura de alta calidad sin impurezas.

Causa: En caso de sirgas de guía de hilo de acero: se están utilizando sirgas de guía de hilo sin revestimiento.

Solución: Utilizar sirgas de guía de hilo revestidas.

Causa: Área de entrada y salida de hilo de la boquilla tensora deformada (ovalada, gastada), el gas protector se escapa de la boquilla tensora.

Solución: Sustituir las boquillas tensoras para garantizar la estanqueidad.

La tobera de gas se calienta mucho

Causa: No se produce ninguna pérdida de calor por estar demasiado flojo el asiento de la tobera de gas.

Solución: Apretar la tobera de gas hasta el tope.

La antorcha de soldadura se calienta mucho

Causa: Solo para antorchas de soldadura Multilock: el racor del cuello antorcha está aflojado.

Solución: Apretar el racor.

Causa: La antorcha de soldadura se ha puesto en servicio por encima de la máxima corriente de soldadura.

Solución: Reducir la potencia de soldadura o utilizar una antorcha de soldadura más potente.

Causa: Dimensiones insuficientes de la antorcha de soldadura.

Solución: Observar la duración de ciclo de trabajo y los límites de carga.

Causa: Solo para equipos refrigerados por agua: caudal líquido de refrigeración insuficiente.

Solución: Comprobar el nivel de refrigerante, el caudal líquido de refrigeración, la suciedad en el refrigerante, el tendido del juego de cables, etc.

Causa: La punta de la antorcha de soldadura está demasiado cerca en el arco voltaico.

Solución: Aumentar el Stickout.

Vida útil corta del tubo de contacto.

- Causa: Rodillos de avance incorrectos.
Solución: Utilizar rodillos de avance correctos.
- Causa: Abrasión del electrodo de soldadura debido a una presión de contacto excesiva en los rodillos de avance.
Solución: Reducir la presión de contacto en los rodillos de avance.
- Causa: Electrodo de soldadura sucio/oxidado.
Solución: Utilizar un electrodo de soldadura de alta calidad sin impurezas.
- Causa: Electrodo de soldadura sin recubrir.
Solución: Utilizar un electrodo de soldadura con un recubrimiento adecuado.
- Causa: Dimensión del tubo de contacto incorrecta.
Solución: Dimensionar el tubo de contacto correctamente.
- Causa: Duración excesiva de ciclo de trabajo de la antorcha de soldadura.
Solución: Reducir la duración de ciclo de trabajo utilizar una antorcha de soldadura más potente.
- Causa: Tubo de contacto excesivamente calentado. No se produce ninguna pérdida de calor por estar demasiado flojo el asiento del tubo de contacto.
Solución: Apretar el tubo de contacto.

¡OBSERVACIÓN!

En caso de aplicaciones CrNi se puede producir un mayor desgaste del tubo de contacto, debido a las características superficiales del electrodo de soldadura CrNi.

Función errónea de la tecla de la antorcha

- Causa: Las conexiones entre la antorcha de soldadura y la fuente de corriente están defectuosas.
Solución: Establecer las conexiones correctamente / Enviar la fuente de corriente o la antorcha de soldadura al Servicio Técnico.
- Causa: Impurezas entre la tecla de la antorcha y la caja de la tecla de la antorcha.
Solución: Quitar las impurezas.
- Causa: Cable de control defectuoso.
Solución: Contactar con el Servicio Técnico.

Porosidad del cordón de soldadura

Causa: Formación de proyecciones en la tobera de gas, por lo que la protección de gas del cordón de soldadura es insuficiente

Solución: Quitar las proyecciones de soldadura.

Causa: Agujeros en el tubo de gas o conexión inexacta del tubo de gas.

Solución: Sustituir el tubo de gas.

Causa: La junta tórica en la conexión central está cortada o defectuosa.

Solución: Sustituir la junta tórica.

Causa: Humedad/condensado en la tubería de gas.

Solución: Secar la tubería de gas.

Causa: Flujo de gas excesivo o insuficiente.

Solución: Corregir el flujo de gas.

Causa: Cantidad de gas insuficiente al comienzo o final de la soldadura.

Solución: Aumentar el flujo previo de gas y el postflujo de gas.

Causa: Electrodo de soldadura de mala calidad u oxidado.

Solución: Utilizar un electrodo de soldadura de alta calidad sin impurezas.

Causa: Aplicable a las antorchas de soldadura refrigeradas por gas: fuga de gas en caso de sirgas de guía de hilo no aisladas.

Solución: En caso de antorchas de soldadura refrigeradas por gas solo se deben utilizar sirgas de guía de hilo aisladas.

Causa: Aplicación en exceso del líquido antiproyecciones.

Solución: Eliminar el líquido antiproyecciones sobrante / aplicar menos líquido antiproyecciones.

Causa: Aspiración excesiva.

Solución: Reducción de la aspiración

Aspiración insuficiente

Causa: Agujeros en el tubo de aspiración.

Solución: Sustituir el tubo de aspiración.

Causa: El filtro del equipo de aspiración está obstruido.

Solución: Sustituir el filtro del equipo de aspiración.

Causa: Las vías de aire están obstruidas.

Solución: Eliminar las obstrucciones.

Causa: Capacidad de extracción insuficiente del equipo de aspiración. Configuración incorrecta de OPT/i FumeEx.

Solución: Utilizar el aparato de aspiración con una potencia más elevada; aumentar la potencia

Datos técnicos

Generalidades

Dimensionamiento de tensión (V-Peak):

- para antorchas guiadas a mano: 113 V
- para antorchas guiadas a máquina: 141 V



Datos técnicos tecla de la antorcha:

- $U_{\text{máx.}} = 5 \text{ V}$
- $I_{\text{máx.}} = 10 \text{ mA}$

El servicio de la tecla de la antorcha solo está permitido en el marco de los datos técnicos.

El producto cumple los requisitos de la norma IEC 60974-7 / - 10 CI. A.

Antorcha de soldadura refrigerado por gas - MTG 250d - 500d

	MTG 250d	MTG 320d	MTG 400d	MTG 500d
I (amp.) 10 min/40° C CO ²	40% DC* 250 60% DC* 200 100% DC* 170	40% DC* 320 60% DC* 260 100% DC* 210	40% DC* 400 60% DC* 320 100% DC* 260	40% DC* 500 60% DC* 400 100% DC* 320
I (amp.) 10 min/40° C M21	40% DC* 200 60% DC* 160 100% DC* 120	40% DC* 260 60% DC* 210 100% DC* 160	40% DC* 320 60% DC* 260 100% DC* 210	40% DC* 400 60% DC* 320 100% DC* 260
 [mm (in.)]	0,8-1,2 (.032-.047)	0,8-1,6 (.032-.063)	1,0-1,6 (.039-.063)	1,0-1,6 (.039-.063)
 [m (ft.)]	3,5 / 4,5 (12 / 15)	3,5 / 4,5 (12 / 15)	3,5 / 4,5 (12 / 15)	3,5 / 4,5 (12 / 15)

* DC = Duración de ciclo de trabajo

Cuello antorcha refrigerado por gas - MTB 250i, 320i, 330i, 400i, 550i G ML

	MTB 250i G ML	MTB 320i G ML	MTB 330i G ML
I (amperios) 10 min/40° C M21+C1 (EN 439)	40 % ED* 250 60 % ED* 200 100 % ED* 170	40 % ED* 320 60 % ED* 260 100 % ED* 210	40 % ED* 330 60 % ED* 270 100 % ED* 220
 [mm (in.)]	0,8-1,2 (.032-.047)	0,8-1,6 (.032-.063)	0,8-1,6 (.032-.063)



* ED = duración de ciclo de trabajo

	MTB 400i G ML	MTB 550i G ML
I (amperios) 10 min/40° C C1 (EN 439)	-	30 % ED* 550

	MTB 400i G ML	MTB 550i G ML
I (amperios) 10 min/40° C M21 (EN 439)	-	30 % ED* 520
I (amperios) 10 min/40° C M21+C1 (EN 439)	40 % ED* 400 60 % ED* 320 100 % ED* 260	- 60 % ED* 420 100 % ED* 360
 [mm (in.)]	0,8-1,6 (.032-.063)	0,8-1,6 (.032-.063)



* ED = duración de ciclo de trabajo

Juego de cables refrigerado por gas - MHP 400d G ML

	MHP 400d G ML
I (amperios) 10 min/40° C CO ²	40 % DC* 400 60 % DC* 320 100 % DC* 260
I (amperios) 10 min/40° C M21	40 % DC* 320 60 % DC* 260 100 % DC* 210
 [mm (in.)]	0,8-1,6 (.032-.063)
 [m (ft.)]	3,35 / 4,35 (11 / 14)

* DC = Duración de ciclo de trabajo







Juego de cables refrigerado por gas - MHP 500d G ML M

	MHP 500d G ML M
I (amp.) 10 min/40° C CO ²	40 % DC* 500 60 % DC* 400 100 % DC* 320
I (amp.) 10 min/40° C M21	40 % DC* 400 60 % DC* 320 100 % DC* 260
 [mm (in.)]	0,8-1,6 (.032-.063)
 [m (ft.)]	1,35 / 2,35 / 3,35 (4.4 / 7.7 / 14)

* DC = Duración de ciclo de trabajo

Antorcha de soldadura refrigerado por agua - MTW 250d - 700d



	MTW 250d	MTW 400d	MTW 500d	MTW 700d
I (amp.) 10 min/40° C CO ²	100% DC* 250	100% DC* 400	100% DC* 500	100% DC* 700
I (amp.) 10 min/40° C M21	100% DC* 200	100% DC* 320	100% DC* 400	100% DC* 560

		MTW 250d	MTW 400d	MTW 500d	MTW 700d
 [mm (in.)]		0,8-1,2 (.032-.047)	0,8-1,6 (.032-.063)	0,8-1,6 (.032-.063)	0,8-1,6 (.032-.063)
Q _{min}  [l/min (gal./ min)]		1 (.26)	1 (.26)	1 (.26)	1 (.26)
P _{min}  [W]**		500 (3,5 m) 600 (4,5 m)	800 (3,5 m) 950 (4,5 m)	1400 (3,5 m) 1700 (4,5 m)	1800 (3,5 m) 2200 (4,5 m)
P _{min}  [bar (psi.)]		3 (43)	3 (43)	3 (43)	3 (43)
P _{max}  [bar (psi.)]		5 (72)	5 (72)	5 (72)	5 (72)
 [m (ft.)]		3,5 / 4,5 (12 / 15)	3,5 / 4,5 (12 / 15)	3,5 / 4,5 (12 / 15)	3,5 / 4,5 (12 / 15)



* DC = Duración de ciclo de trabajo

** Mínima potencia de refrigeración según la norma IEC 60974-2

**Cuello antorcha
refrigerado por
agua - MTB 250i,
330i, 400i, 500i,
700i W ML**

	MTB 250i W ML	MTB 330i W ML	MTB 400i W ML	MTB 500i W ML
I (amperios) 10 min/40° C M21+C1 (EN 439)	100 % ED* 250	100 % ED* 330	100 % ED* 400	100 % ED* 500
 [mm (in.)]	0,8-1,2 (.032-.047)	0,8-1,6 (.032-.063)	0,8-1,6 (.032-.063)	1,0-1,6 (.039-.063)
Q _{min}  [l/min (gal./min)]	1 (.26)	1 (.26)	1 (.26)	1 (.26)







* ED = duración de ciclo de trabajo

	MTB 700i W ML
I (amperios) 10 min/40° C M21+C1 (EN 439)	100 % ED* 700
 [mm (in.)]	1,0-1,6 (.039-.063)
Q _{min}  [l/min (gal./min)]	1 (.26)

* ED = duración de ciclo de trabajo

**Juego de cables
refrigerado por
agua - MHP
500d, 700d W
ML**







	MHP 500d W ML	MHP 700d W ML
I (amperios) 10 min/40° C CO ²	100 % DC* 500	100 % DC* 700

		MHP 500d W ML	MHP 700d W ML
I (amperios) 10 min/40° C M21		100 % DC* 400	100 % DC* 560
 [mm (in.)]		0,8-1,6 (.032-.063)	0,8-1,6 (.032-.063)
 [m (ft.)]		3,35 / 4,35 (11 / 14)	3,35 / 4,35 (11 / 14)
P _{min}  [W]**		1400 / 1700	1800 / 2200
Q _{min}  [l/min (gal./min.)]		1 (.26)	1 (.26)
P _{min}  [bar (psi.)]		3 (43)	3 (43)
P _{max}  [bar (psi.)]		5 (72)	5 (72)

* DC = Duración de ciclo de trabajo

** Mínima potencia de refrigeración según la norma IEC 60974-2



Juego de cables refrigerado por agua - MHP 700d W ML M

		MHP 700d W ML M
I (amperios) 10 min/40° C CO ²		100 % DC* 700
I (amperios) 10 min/40° C M21		100 % DC* 560
 [mm (in.)]		0,8-1,6 (.032-.063)
 [m (ft.)]		1,35 / 2,35 / 3,35 (4.4 / 7.7 / 14)
P _{min}  [W]**		1100 / 1450 / 1800
Q _{min}  [l/min (gal./min.)]		1 (.26)
P _{min}  [bar (psi.)]		3 (43)
P _{max}  [bar (psi.)]		5 (72)

* DC = Duración de ciclo de trabajo

** Mínima potencia de refrigeración según la norma IEC 60974-2





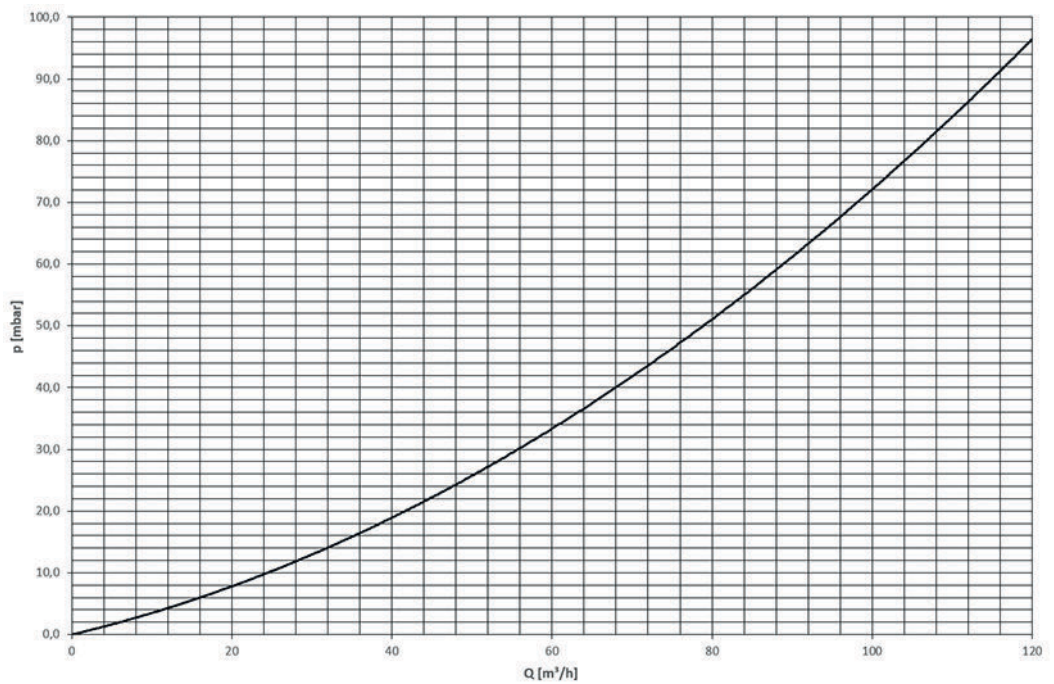

MTG 400d K4

		MTG 400d K4
I (amp.) 10 min/40° C CO ₂ / mixed		40 % DC* 400 60 % DC* 320 100 % DC* 260
 [mm (in.)]		0,8-1,6 (.032-.063)
 [m (ft.)]		4,5 (15)

* DC = Duración de ciclo de trabajo

Curva característica de aspiración MTG 400d K4

MTW 500d K4

		MTW 500d K4
I (amperios) 10 min/40° C CO ₂ / mixed		100 % DC* 500
 [mm (in.)]		0,8-1,6 (.032-.063)
 [m (ft.)]		4,5 (15)
P _{max}  [W]**		1700
Q _{min}  [l/min (gal./min)]		1 (26)
P _{min}  [bar (psi.)]		3 (43)
P _{max}  [bar (psi.)]		5 (72)

* DC = Duración de ciclo de trabajo

** Mínima potencia de refrigeración según la norma IEC 60974-2

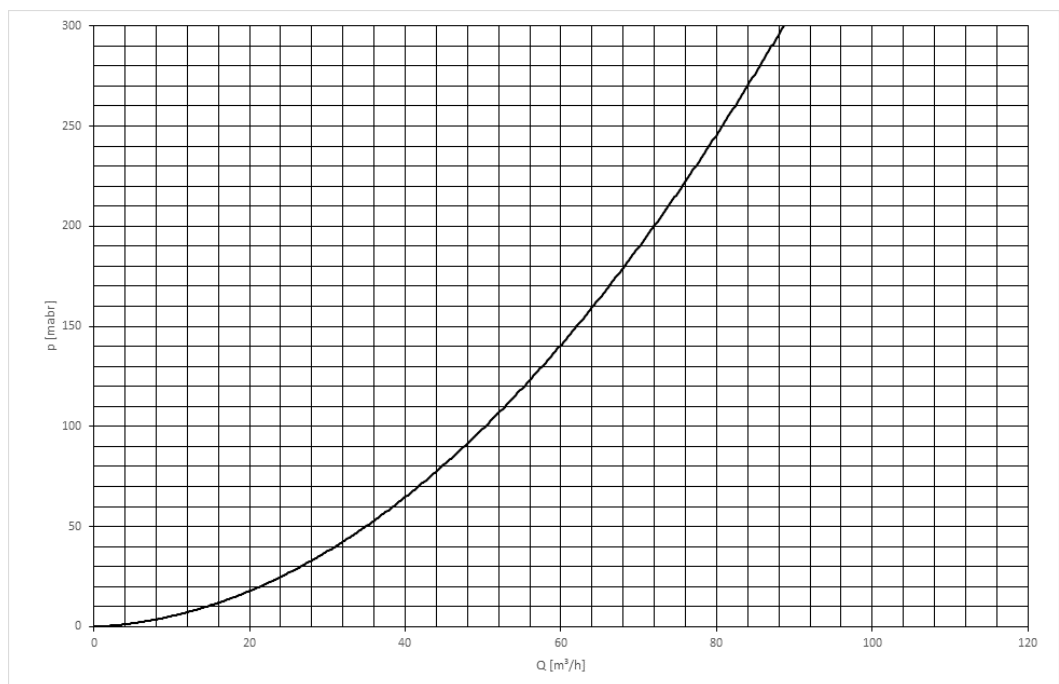
Curva característica de aspiración MTW 500d K4

Sommaire

Sécurité.....	106
Utilisation conforme à la destination.....	106
Sécurité.....	106
Risque lié aux fumées de soudage.....	107
MTG d, MTW d, MHP d – Généralités.....	108
Fonction Up/Down.....	108
Fonction JobMaster.....	108
MTG 400d K4, MTW 500d K4 – Généralités.....	110
Généralités.....	110
Valeurs indicatives de l'appareil d'aspiration.....	110
Régulateur de débit d'air.....	110
Fonction Up/Down.....	111
Monter les pièces d'usure sur le corps de torche.....	112
MTG d, MTW d – Monter les pièces d'usure sur le col de cygne.....	112
MTG 400d K4, MTW 500d K4 – Monter les pièces d'usure.....	112
Monter le corps de torche ML sur le faisceau de liaison MHP.....	114
Assembler la torche de soudage Multilock.....	114
Monter les âmes de guidage du fil.....	115
Contrôler le raccord de serrage.....	115
Montage d'une âme de guidage du fil en acier.....	116
Monter une âme de guidage du fil en plastique (F, F++).....	117
Montage de l'âme guide-fil en plastique (raccord Fronius avec buse guide-fil).....	118
Monter une âme de guidage du fil en plastique (Euro).....	119
Mise en service.....	120
Brancher la torche de soudage.....	120
Raccordement de l'aspiration.....	120
Tourner le corps de torche de soudage Multilock.....	121
Remplacer le corps de torche de soudage Multilock.....	122
Support en forme de prisme pour la torche de soudage automatique.....	123
Entretien et maintenance.....	124
Généralités.....	124
Identification des pièces d'usure défectueuses.....	124
Maintenance à chaque mise en service.....	124
Maintenance à chaque remplacement de la bobine de fil/bobine type panier.....	125
Diagnostic d'erreur, élimination de l'erreur.....	127
Diagnostic d'erreur, élimination de l'erreur.....	127
Caractéristiques techniques.....	133
Généralités.....	133
Torche de soudage refroidi par gaz - MTG 250d - 500d.....	133
Col de cygne refroidi par gaz – MTB 250i, 320i, 330i, 400i, 550i G ML.....	133
Faisceau de liaison refroidi par gaz - MHP 400d G ML.....	134
Faisceau de liaison refroidi par gaz - MHP 500d G ML M.....	134
Torche de soudage refroidi par eau - MTW 250d - 700d.....	134
Col de cygne refroidi par eau – MTB 250i, 330i, 400i, 500i, 700i W ML.....	135
Faisceau de liaison refroidi par eau - MHP 500d, 700d W ML.....	136
Faisceau de liaison refroidi par eau - MHP 700d W ML M.....	136
MTG 400d K4.....	137
Caractéristique d'aspiration MTG 400d K4.....	137
MTW 500d K4.....	138
Caractéristique d'aspiration MTW 500d K4.....	138

Sécurité

Utilisation conforme à la destination

La torche de soudage manuelle MIG/MAG est exclusivement destinée au soudage MIG/MAG lors d'applications manuelles. Toute autre utilisation est considérée comme non conforme. Le fabricant ne saurait être tenu pour responsable des dommages consécutifs.

Font également partie de l'emploi conforme :

- le respect de toutes les indications des instructions de service ;
 - le respect des travaux d'inspection et de maintenance.
-

Sécurité

AVERTISSEMENT!

Danger dû à une erreur de manipulation et d'erreur en cours d'opération.

Cela peut entraîner des dommages corporels et matériels graves.

- ▶ Toutes les fonctions et tous les travaux décrits dans le présent document doivent uniquement être exécutés par du personnel techniquement qualifié.
 - ▶ Ce document doit être lu et compris dans son intégralité.
 - ▶ Lire et comprendre toutes les consignes de sécurité et la documentation utilisateur de cet appareil et de tous les composants périphériques.
-

AVERTISSEMENT!

Risque d'électrocution.

Cela peut entraîner des dommages corporels et matériels graves.

- ▶ Avant d'entamer les travaux, déconnecter tous les appareils et composants concernés et les débrancher du réseau électrique.
 - ▶ S'assurer que tous les appareils et composants concernés ne peuvent pas être remis en marche.
-

AVERTISSEMENT!

Danger dû à un courant électrique suite à des composants périphériques défectueux et une erreur de manipulation.

Cela peut entraîner des dommages corporels et matériels graves.

- ▶ Tous les câbles, conduites et faisceaux de liaison doivent toujours être solidement raccordés, intacts et correctement isolés.
 - ▶ N'utiliser que des câbles, conduites et faisceaux de liaison de dimensions suffisantes.
-

AVERTISSEMENT!

Risque de glissement en cas de fuite de réfrigérant.

Cela peut entraîner des dommages corporels et matériels graves.

- ▶ Toujours raccorder les tuyaux à réfrigérant des torches de soudage refroidies par eau avec le dispositif de fermeture en plastique monté dessus lorsque ceux-ci sont séparés du refroidisseur ou d'autres composants périphériques.
-



AVERTISSEMENT!

Danger en cas de contact avec les composants périphériques et/ou l'équipement.

Cela peut entraîner de graves brûlures.

- ▶ Avant d'entamer les travaux, laisser refroidir tous les composants périphériques et/ou l'équipement chauds à +25 °C / +77 °F (par ex. réfrigérant, composants périphériques refroidis à l'eau, moteur d'entraînement du dévidoir, ...).
- ▶ Porter un équipement de protection adapté (par ex. gants de protection résistant à la chaleur, lunettes de protection, ...) si le refroidissement n'est pas possible.



AVERTISSEMENT!

Danger en cas de contact avec les fumées de soudage toxiques.

Cela peut entraîner des dommages corporels graves.

- ▶ Toujours extraire les fumées de soudage.
- ▶ Veiller à assurer une aération suffisante. S'assurer que le taux de ventilation soit toujours de 20 m³/heure (169070.1 US gi).
- ▶ En cas de doute, demander à un technicien de sécurité de déterminer le niveau de substances nocives sur le poste de travail.



ATTENTION!

Danger en cas de fonctionnement sans réfrigérant.

Cela peut entraîner des dommages matériels.

- ▶ Ne jamais mettre en service les appareils refroidis par eau sans réfrigérant.
- ▶ Pendant le soudage, s'assurer que le débit de réfrigérant est correct - c'est le cas en cas d'utilisation d'appareils refroidis par eau Fronius, lorsqu'un reflux correct du réfrigérant est visible dans le réservoir de réfrigérant du refroidisseur.
- ▶ Le fabricant n'est pas responsable des dommages dus au non-respect des points énoncés ci-dessus, tous les droits à la garantie sont annulés.

Risque lié aux fumées de soudage



AVERTISSEMENT!

Risque lié à la fumée qui se dégage lors du soudage et qui contient des gaz et des vapeurs nocifs pour la santé.

Cela peut entraîner de graves problèmes de santé.

- ▶ Le soudage n'est pas autorisé quand l'appareil d'aspiration n'est pas activé.
- ▶ Dans certaines circonstances, l'utilisation seule d'une torche aspirante ne suffit pas.
Dans ce cas, installer une aspiration supplémentaire pour réduire les substances nocives sur le poste de travail.
- ▶ En cas de doute, demander à un technicien de sécurité de déterminer le niveau de substances nocives sur le poste de travail.

MTG d, MTW d, MHP d – Généralités

Fonction Up/Down

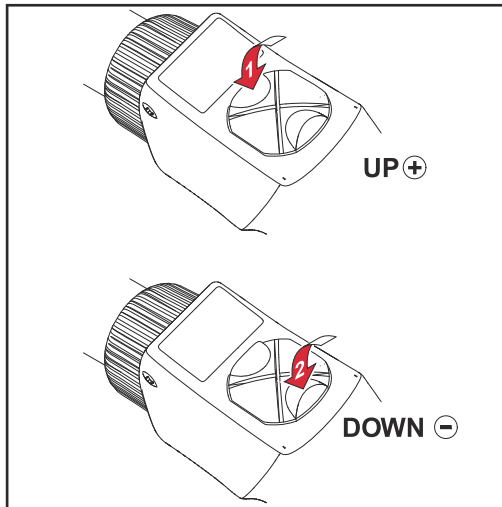

- Sélectionner un des paramètres suivants au niveau de la source de courant :
 - Vitesse d'avance du fil
 - N° job
- Régler le paramètre au moyen de la fonction Up/Down

IMPORTANT! Des paramètres supplémentaires peuvent être réglés dans les modes de service de soudage MIG/MAG standard et Puls Synergic.

Fonction Job-Master

IMPORTANT! Des messages codés peuvent apparaître au niveau du JobMaster. Ils correspondent au code de service affiché simultanément sur le panneau de commande (voir les Instructions de service de la source de courant, chapitre « Diagnostic et élimination des pannes »).

SynchroPuls (Option) – aucun symbole n'est allumé sur le JobMaster (voir les Instructions de service de la source de courant, chapitre « Soudage MIG/MAG »).

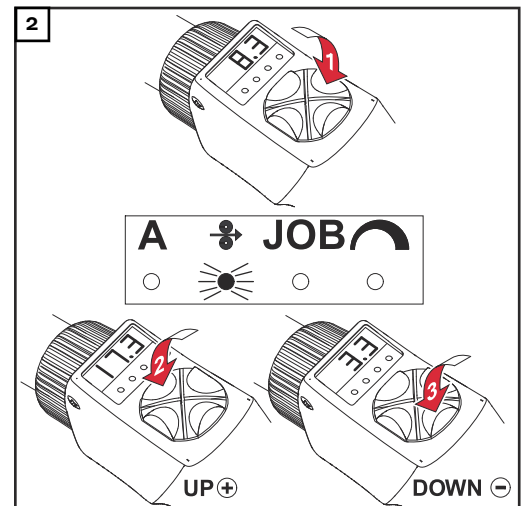
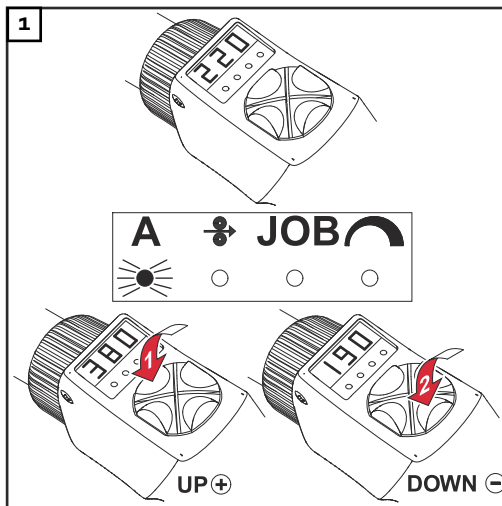

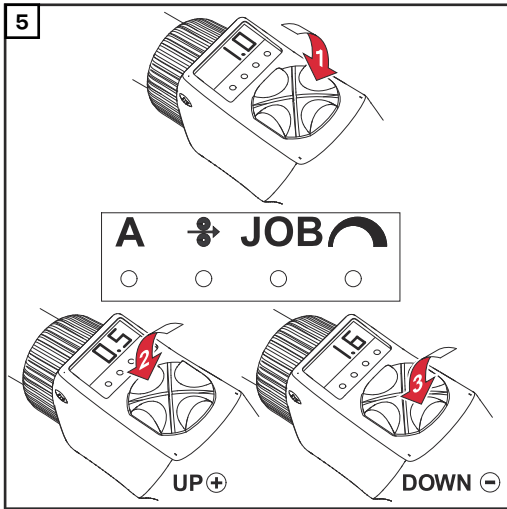
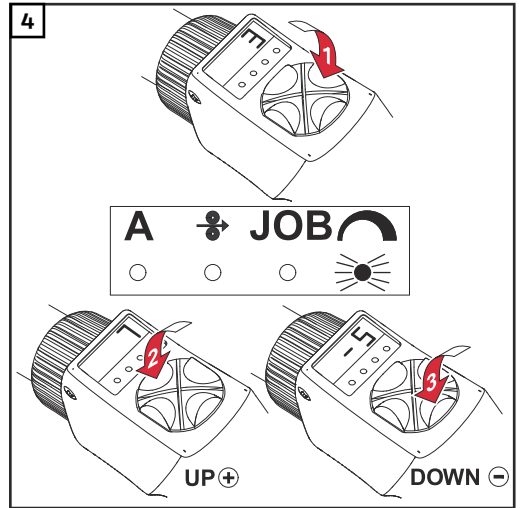
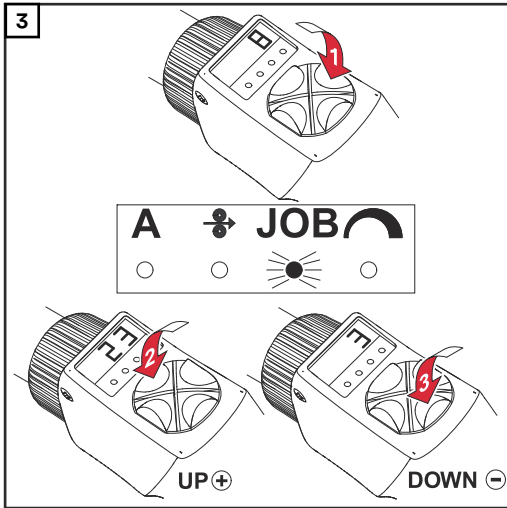

MTG 400d K4, MTW 500d K4 – Généralités

Généralités

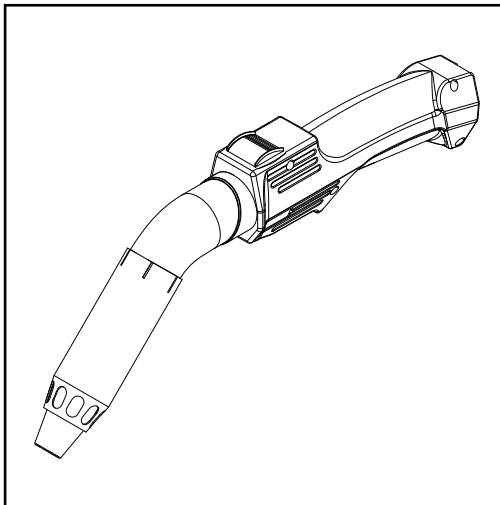

Les torches aspirantes MTG 400d K4 et MTW 500d K4 détectent les fumées de soudage nocives produites pendant le soudage dès leur apparition.

Les fumées de soudage sont aspirées avant d'atteindre la zone de respiration du soudeur.

La concentration maximale admissible sur le lieu de travail (MAK) prévue par la loi peut être atteinte mais jamais dépassée.

Valeurs indicatives de l'appareil d'aspiration

L'appareil d'aspiration de la torche aspirante doit répondre aux spécifications suivantes :

Puissance d'aspiration

env. 100 m³/h

Valeurs de dépression

entre 0,05 et 0,2 bar
(entre 5 000 et 20 000 Pa)

Régulateur de débit d'air

Avec le régulateur de débit d'air, la quantité de fumées de soudage aspirées pendant le processus de soudage peut être réglée progressivement de 10 à 100 %.

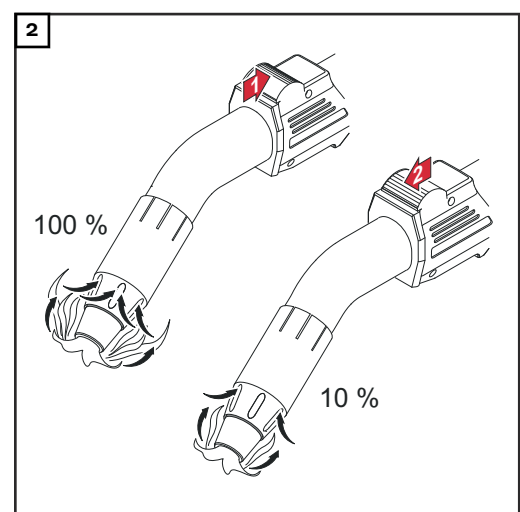
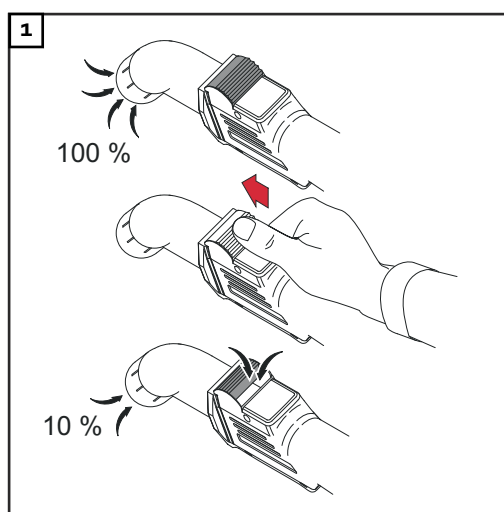

IMPORTANT ! La quantité de fumées de soudage aspirées doit être réglée si le gaz de protection est aspiré avec les fumées de soudage (par ex. lors du soudage en angle).

**Fonction Up/
Down**

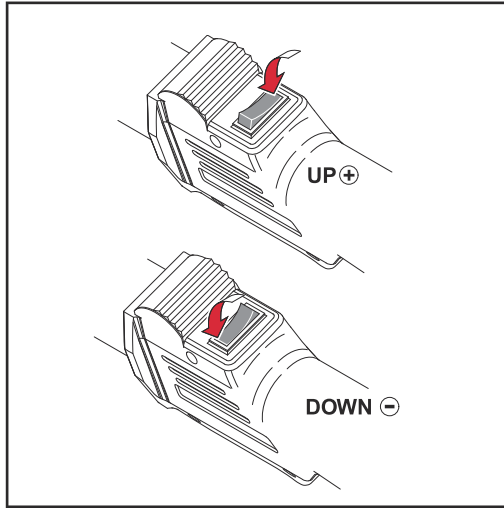

Monter les pièces d'usure sur le corps de torche

MTG d, MTW d –
Monter les
pièces d'usure
sur le col de cyg-
ne

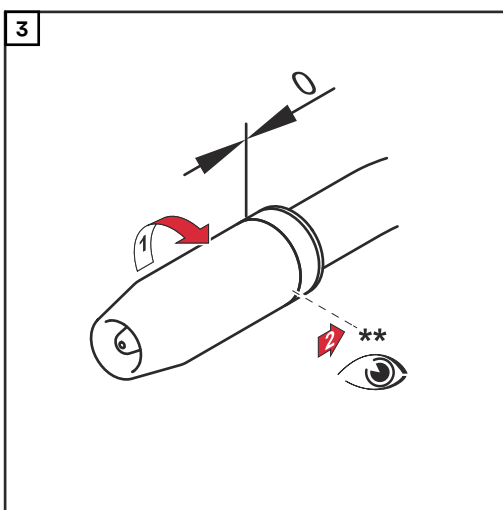
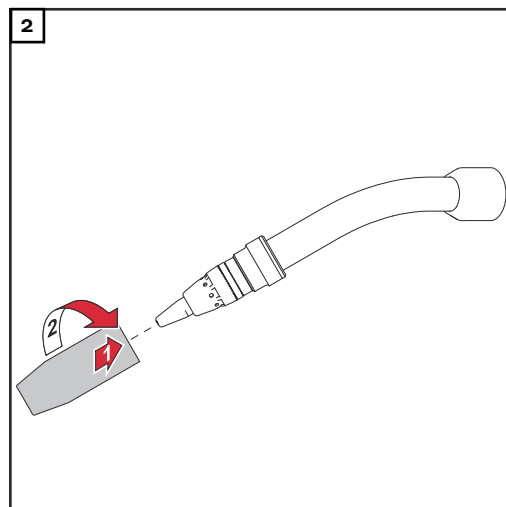
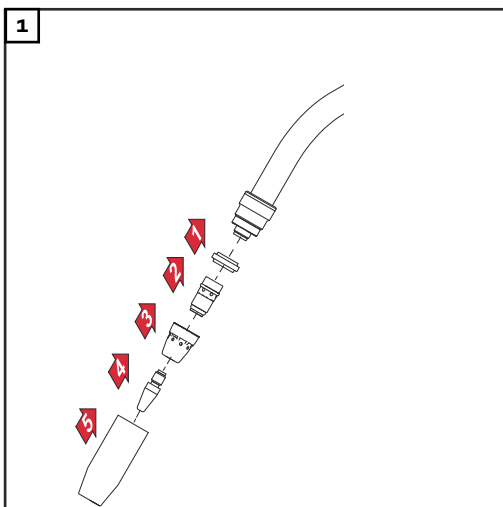

** Serrer la buse de gaz jusqu'à la butée

MTG 400d K4,
MTW 500d K4 –
Monter les
pièces d'usure

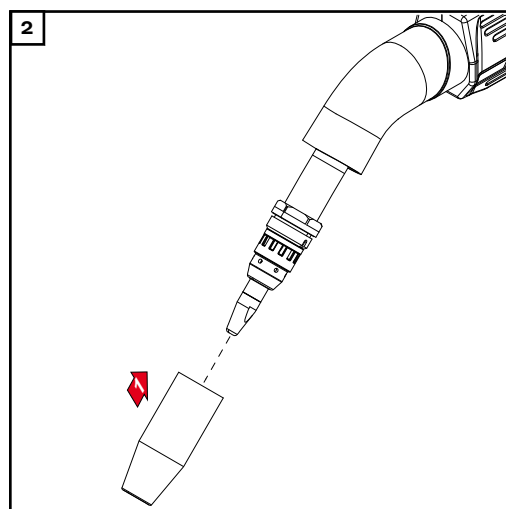
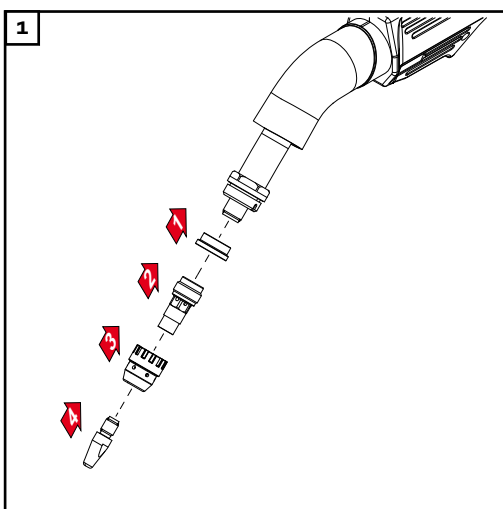

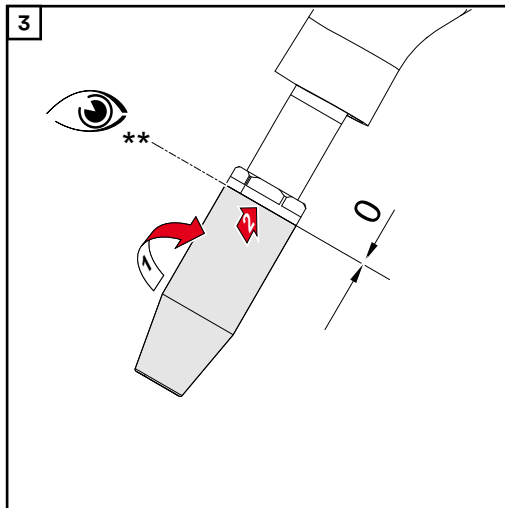

** Serrer la buse de gaz jusqu'à la butée

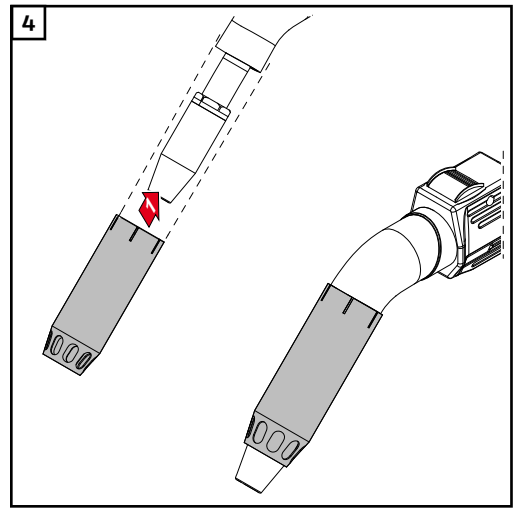

Mettre la buse d'aspiration en place

Monter le corps de torche ML sur le faisceau de liaison MHP

Assembler la torche de soudage Multilock

REMARQUE!

Risque de dommages sur la torche de soudage. Toujours visser l'écrou-raccord du corps de torche de soudage jusqu'à la butée.

REMARQUE!

Sur les torches de soudage refroidies par eau, le serrage de l'écrou-raccord peut présenter une résistance plus importante en raison du mode de construction de la torche de soudage. Ce phénomène est normal. Toujours visser l'écrou-raccord du corps de torche de soudage jusqu'à la butée.

REMARQUE!

Avant le montage du corps de torche de soudage, vérifier que le dispositif d'accouplement du corps de torche de soudage et du faisceau de liaison est intact et propre.

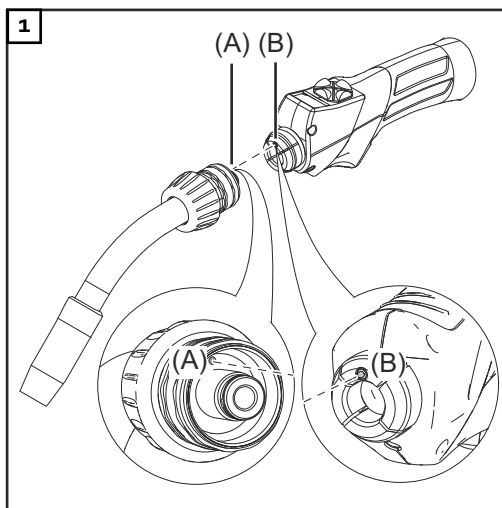

REMARQUE!

Lorsque le goujon d'adaptation (A) du faisceau de liaison s'enclenche dans le perçage (B) du corps de torche de soudage, le corps de torche de soudage se trouve dans la position 0°.

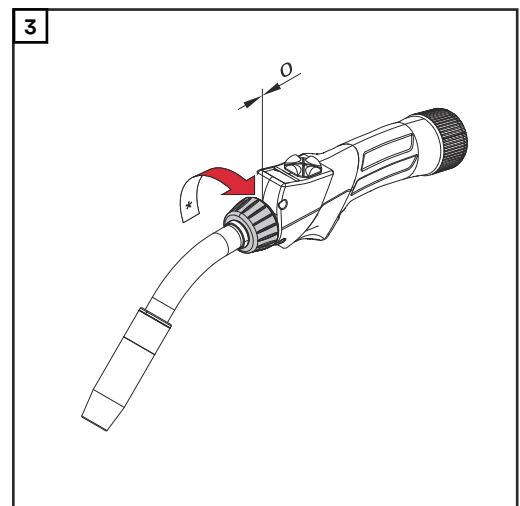
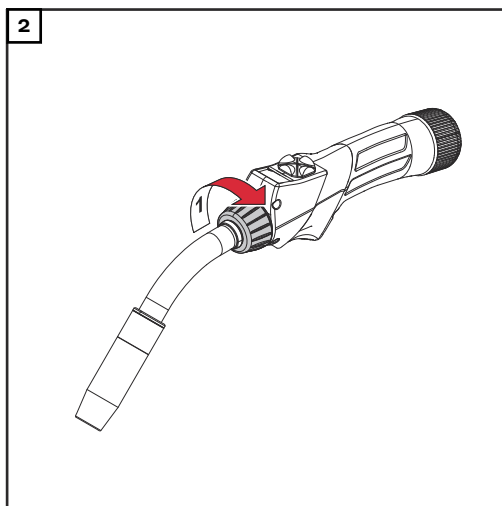

* S'assurer que l'écrou-raccord est vissé jusqu'à la butée.

Monter les âmes de guidage du fil

Contrôler le raccord de serrage

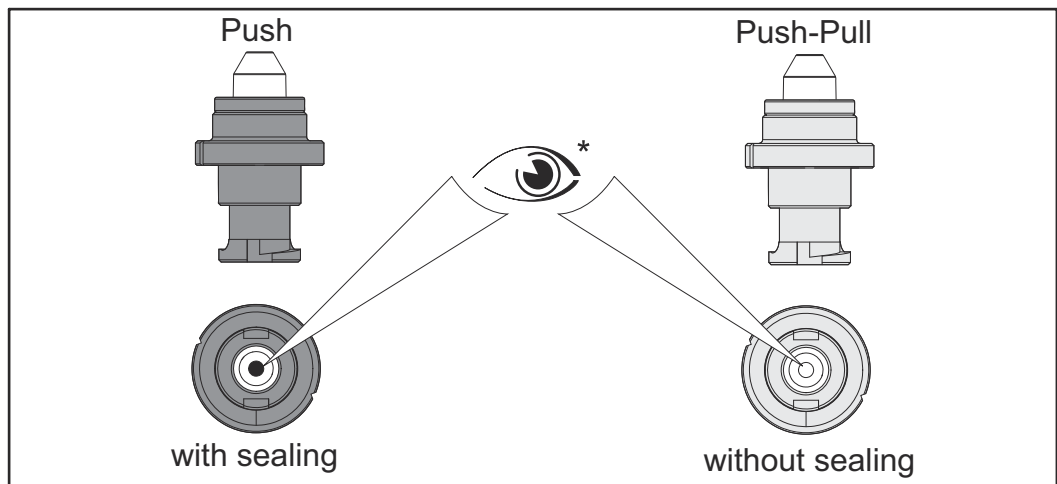

- * Contrôler le raccord de serrage avant la mise en service et à chaque remplacement de la gaine guide-fil. Effectuer un contrôle visuel :
- à gauche : raccord de serrage en laiton avec rondelle d'étanchéité. Il est impossible de voir à travers la rondelle d'étanchéité.
 - à droite : raccord de serrage argenté avec passage visible

REMARQUE!

Raccord de serrage incorrect ou défectueux dans les applications Push

Cela peut entraîner des pertes de gaz et de mauvaises caractéristiques de soudage.

- Utiliser des raccords de serrage en laiton afin de minimiser les pertes de gaz
- Vérifier que la rondelle d'étanchéité est intacte

REMARQUE!

Raccord de serrage incorrect dans les applications Push-Pull

Enrouleur de fil et abrasion accrue dans la gaine guide-fil en cas d'utilisation d'un raccord de serrage avec rondelle d'étanchéité

- Utiliser des raccords de serrage argentés afin de faciliter le guidage du fil

**Montage d'une
âme de guidage
du fil en acier**

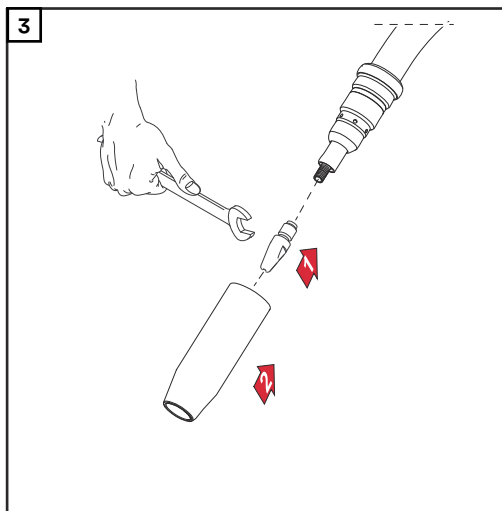
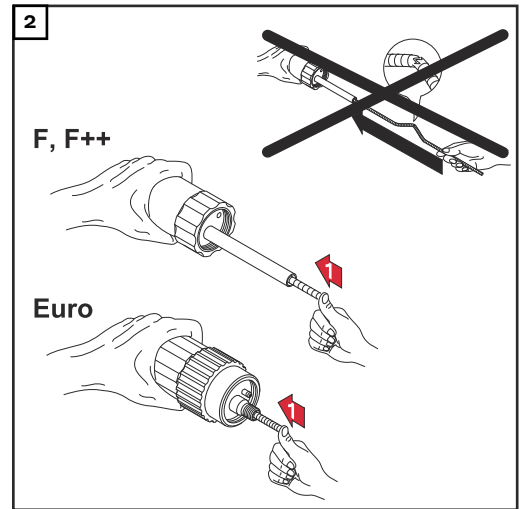
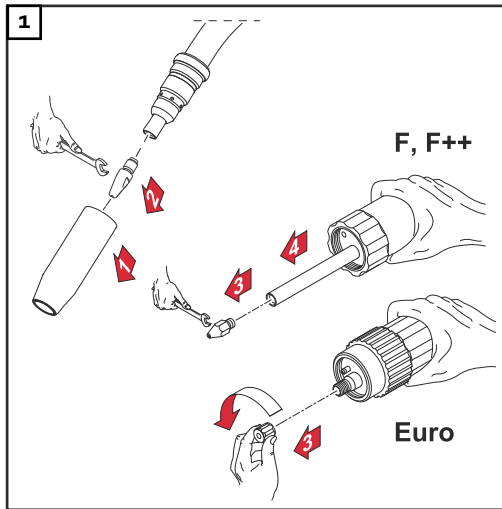

F++, F:

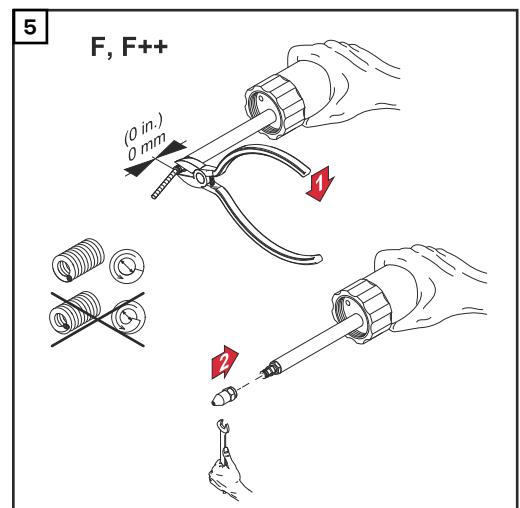
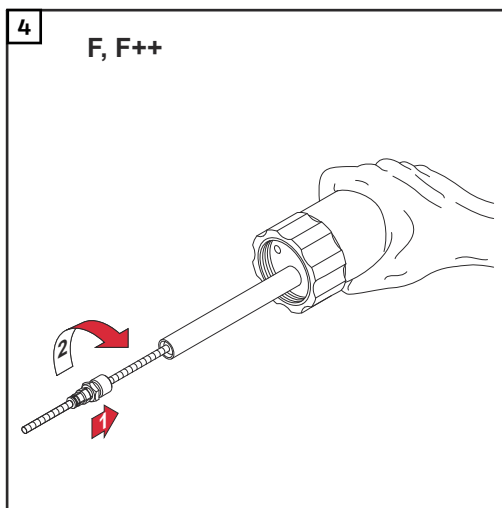

Euro :

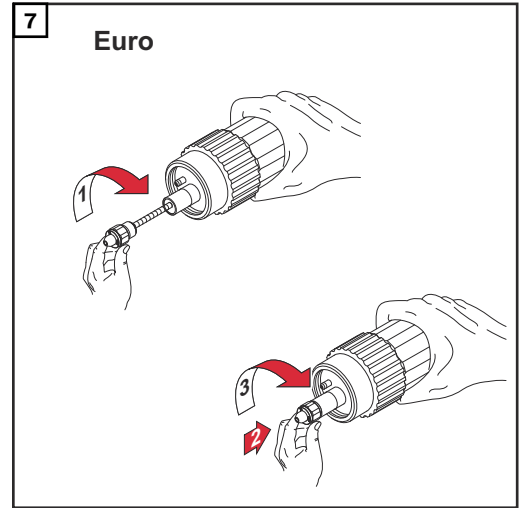
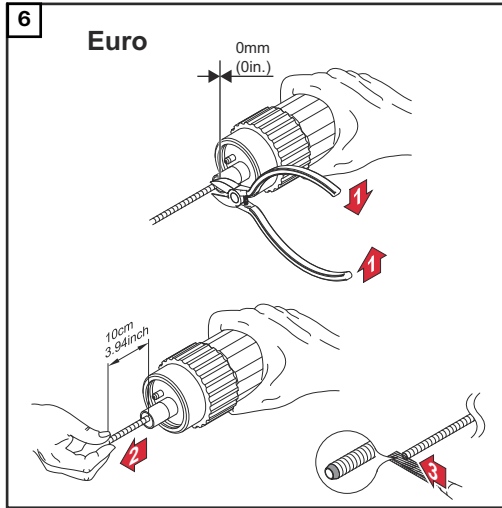

Monter une âme de guidage du fil en plastique (F, F++)

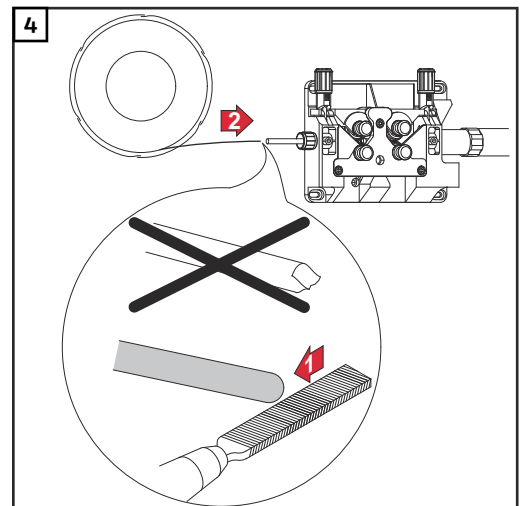
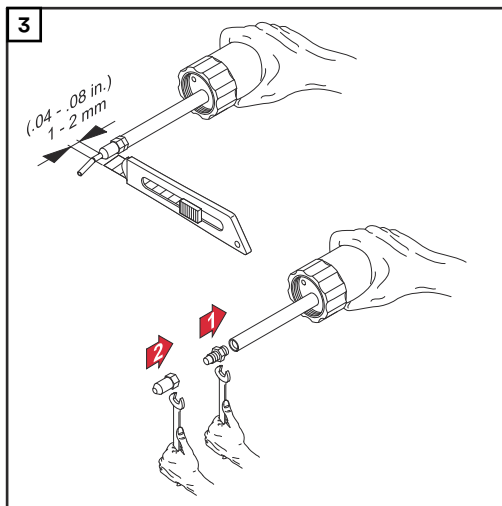
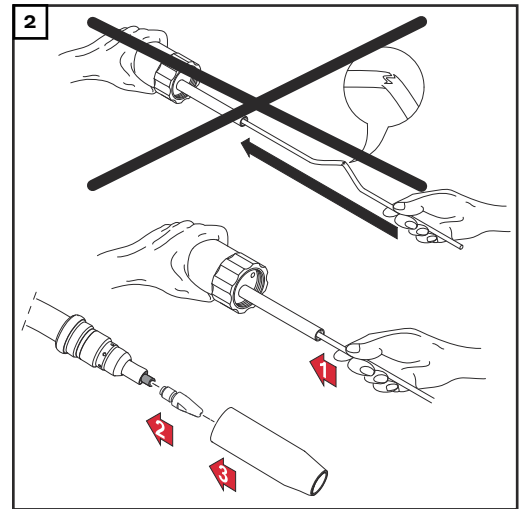
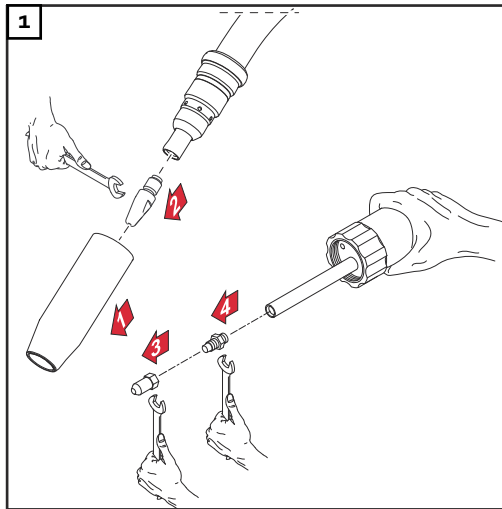

FR

Montage de l'âme guide-fil en plastique (raccord Fronius avec buse guide-fil)

REMARQUE!

Avant d'insérer le fil-électrode, arrondir l'extrémité du fil-électrode.

Valable pour les âmes en téflon, les âmes combinées et les âmes en graphite

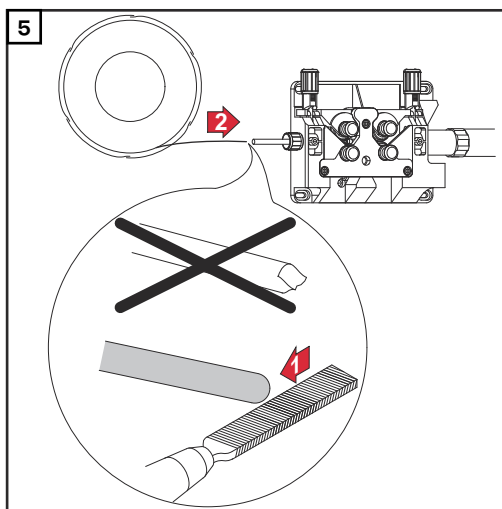
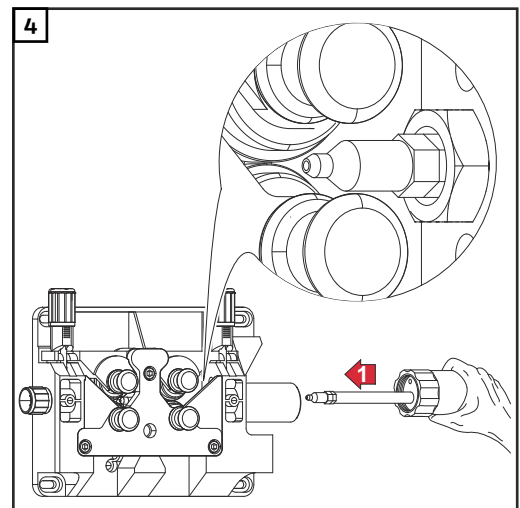
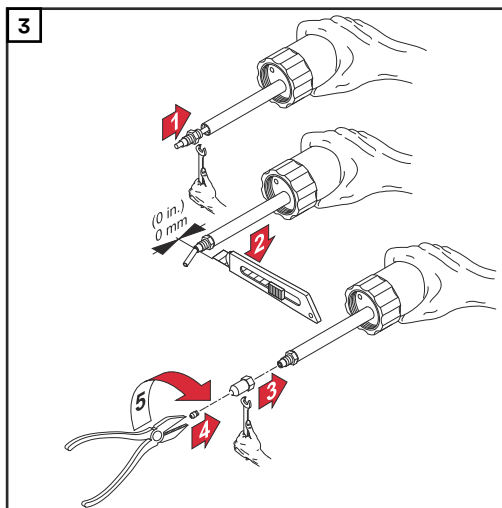
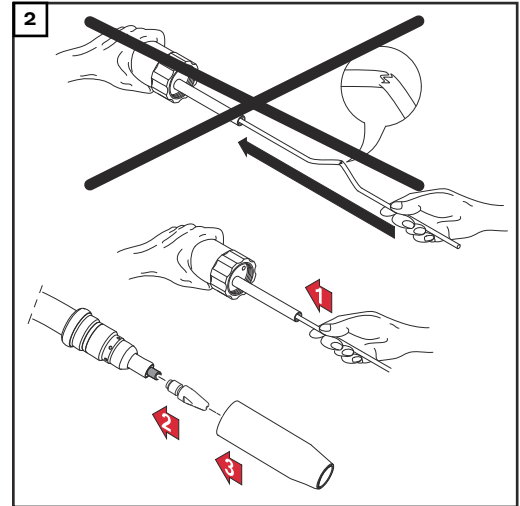
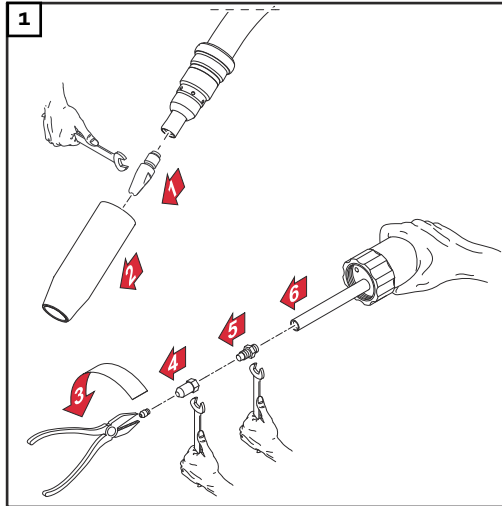

Monter une âme de guidage du fil en plastique (Euro)

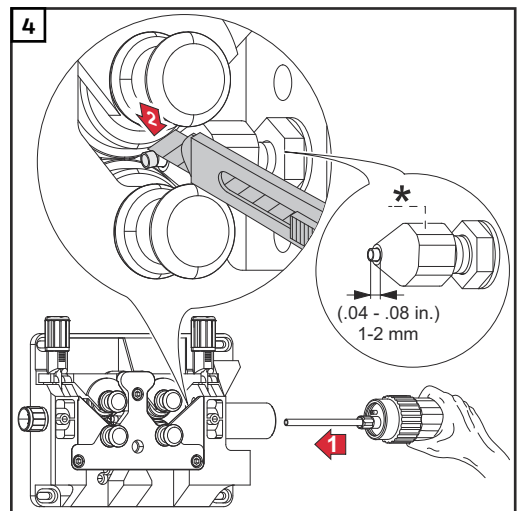
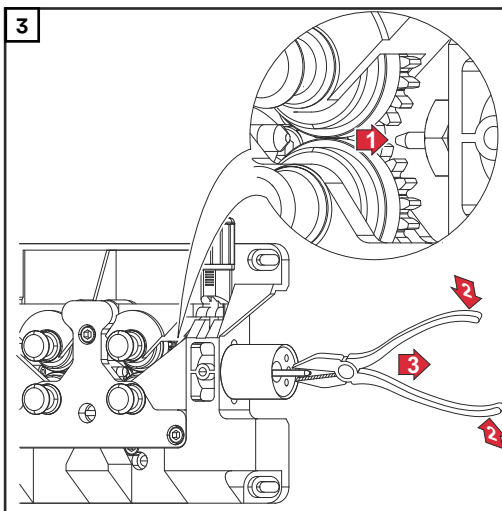
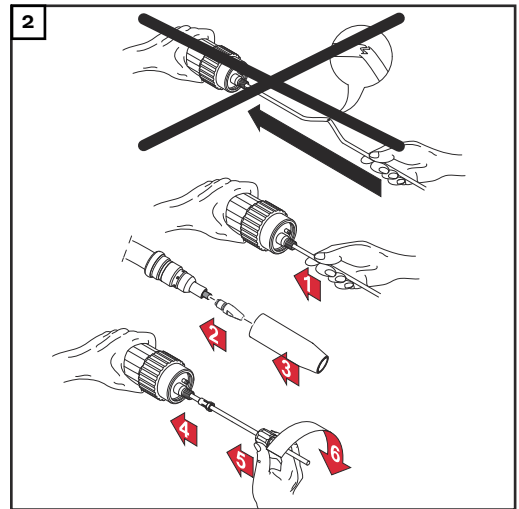
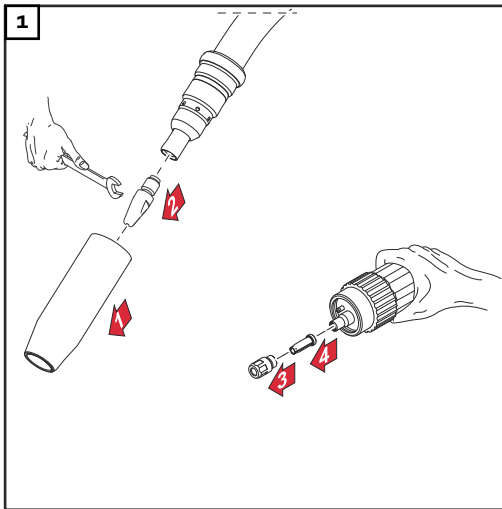

* Option Buse d'entrée du fil (42,0001,5421)

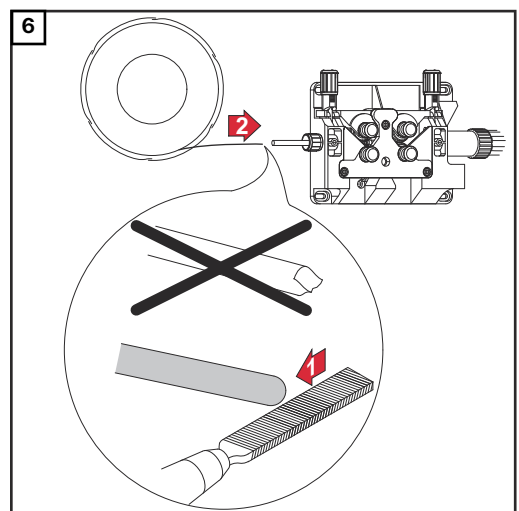
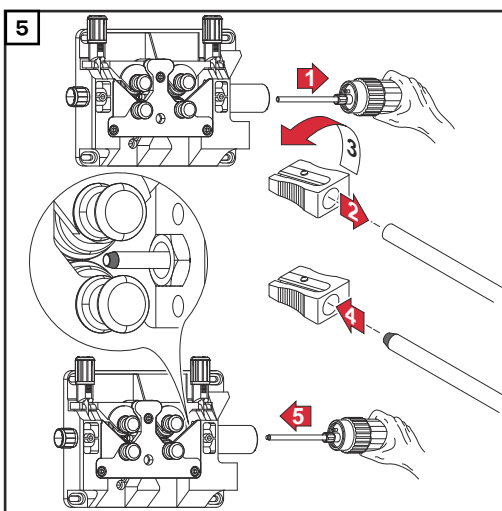

Mise en service

Brancher la torche de soudage

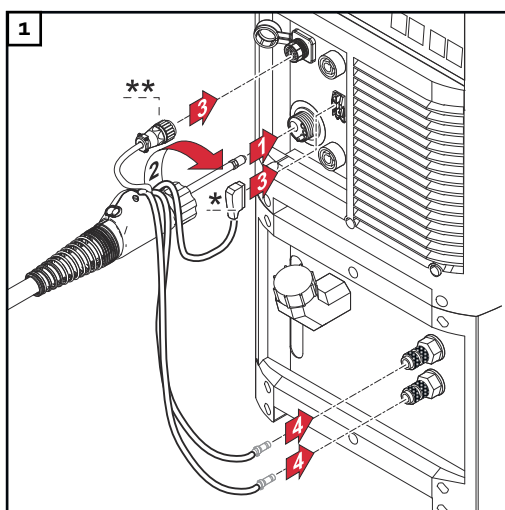

- * Connecteur LocalNet (torche de soudage Standard ou Up/Down)
- ** Connecteur JobMaster (torche de soudage JobMaster)

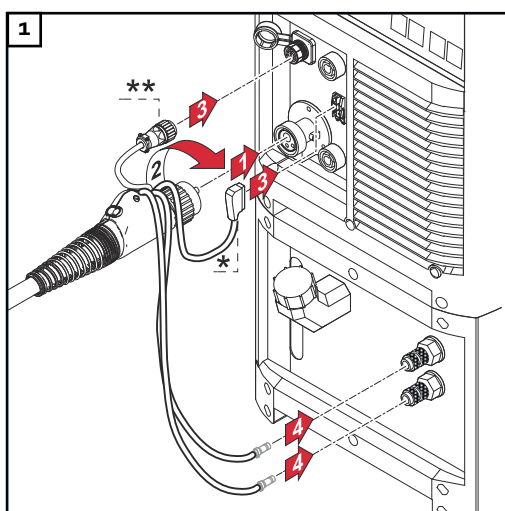

- * Connecteur LocalNet (torche de soudage Standard ou Up/Down)
- ** Connecteur JobMaster (torche de soudage JobMaster)

Raccordement de l'aspiration

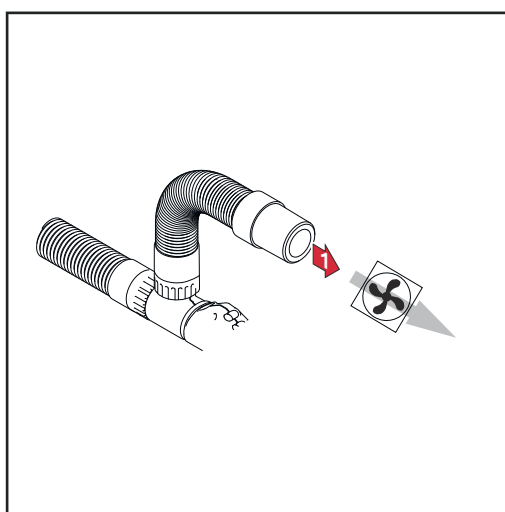

- 1 Raccorder le tuyau d'aspiration à l'appareil d'aspiration selon les valeurs indicatives des appareils d'aspiration

Tourner le corps de torche de soudage Multi-lock

⚠ ATTENTION!

Risque de brûlure en cas de contact avec le réfrigérant ou le corps de torche de soudage chauds.

► Avant d'effectuer toute opération, laisser refroidir le réfrigérant et le corps de torche de soudage à température ambiante (+25 °C, +77 °F).

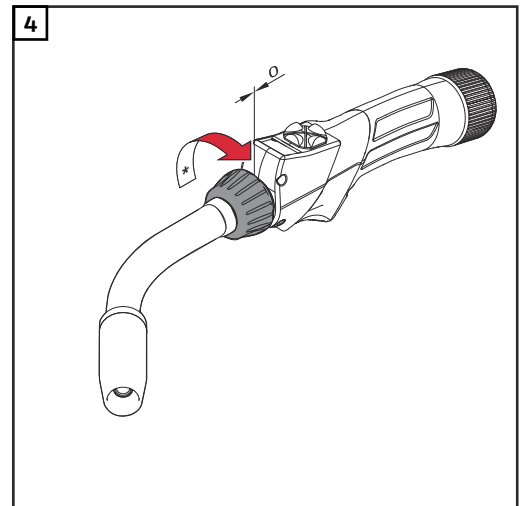
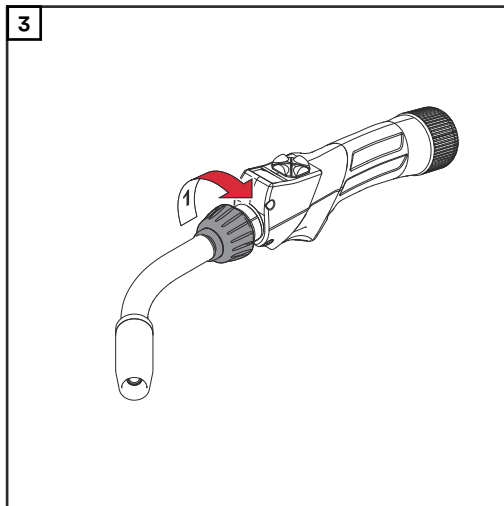
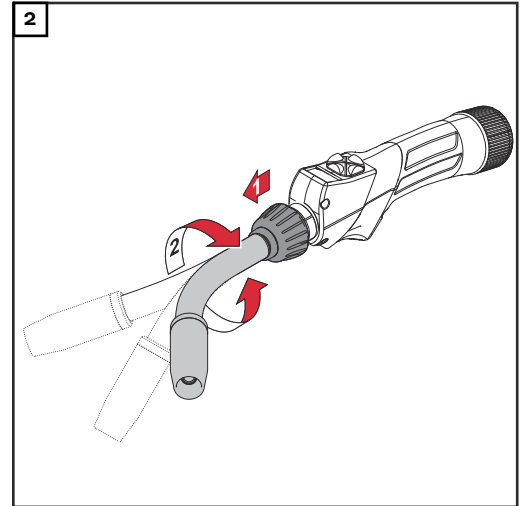
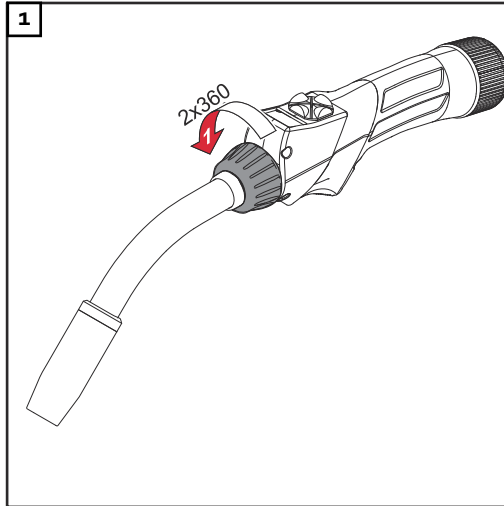

* S'assurer que l'écrou-raccord est vissé jusqu'à la butée.

Remplacer le corps de torche de soudage Multilock

⚠ ATTENTION!

Risque de brûlure en cas de contact avec le réfrigérant ou le corps de torche de soudage chauds.

Cela peut entraîner de graves brûlures.

- ▶ Avant d'effectuer toute opération, laisser refroidir le réfrigérant et le corps de torche de soudage à température ambiante (+25 °C, +77 °F).

REMARQUE!

Il reste toujours un peu de réfrigérant dans le corps de torche de soudage.

Démonter le corps de torche de soudage uniquement avec la buse de gaz orientée vers le bas.

REMARQUE!

Avant le montage du corps de torche de soudage, vérifier que le dispositif d'accouplement du corps de torche de soudage et du faisceau de liaison est intact et propre.

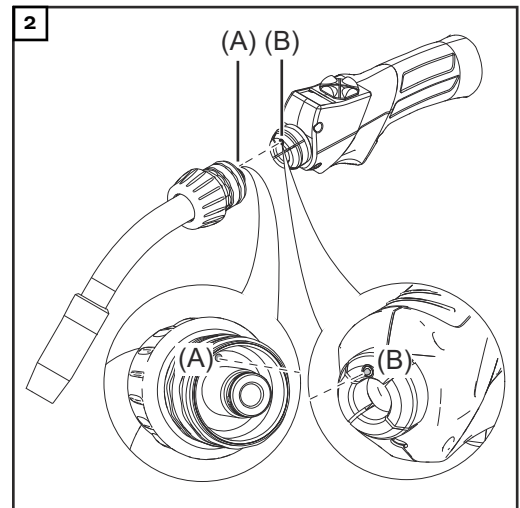
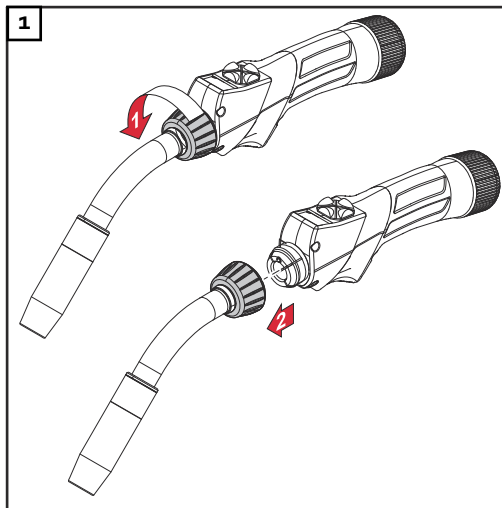

REMARQUE!

Lorsque le goujon d'adaptation (A) du faisceau de liaison s'enclenche dans le perçage (B) du corps de torche de soudage, le corps de torche de soudage se trouve dans la position 0°.

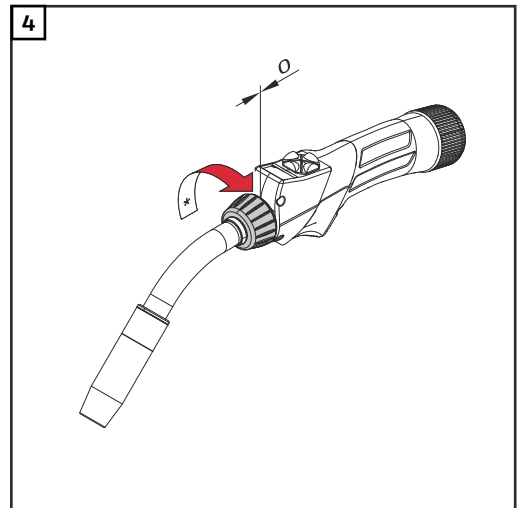
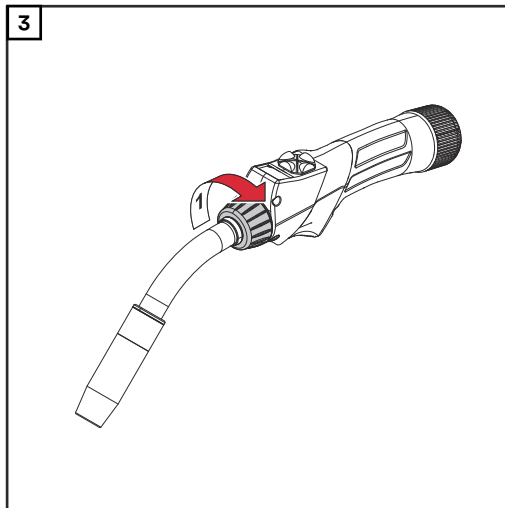

* S'assurer que l'écrou-raccord est vissé jusqu'à la butée.

Support en forme de prisme pour la torche de soudage automatique

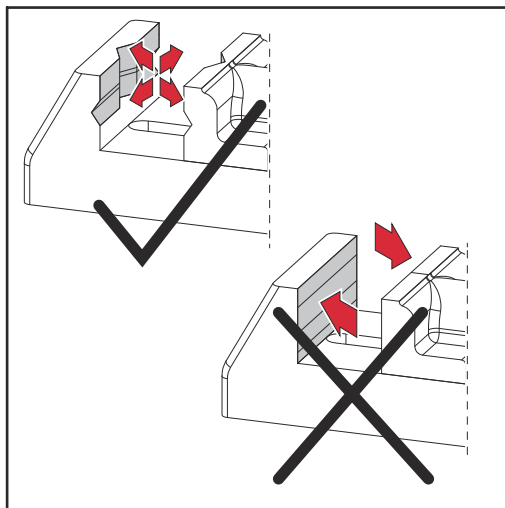

Placer la torche de soudage automatique pour usinage uniquement dans un support en forme de prisme !

Entretien et maintenance

Généralités

Une maintenance régulière et préventive de la torche de soudage constitue un facteur important permettant d'en garantir le bon fonctionnement. La torche de soudage est soumise à des températures élevées et à un degré de salissure très important. Elle nécessite donc une maintenance plus fréquente que les autres composants du système de soudage.

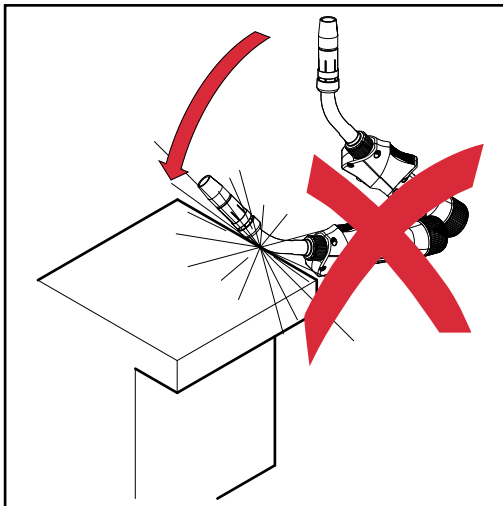

ATTENTION!

Risque en cas de mauvaise manipulation de la torche de soudage.

Cela peut entraîner de graves dommages matériels.

- ▶ Ne pas cogner la torche de soudage contre des objets durs.
- ▶ Éviter d'érafler et de rayer le tube contact.
- ▶ Ne jamais plier le col de cygne.

Identification des pièces d'usure défectueuses

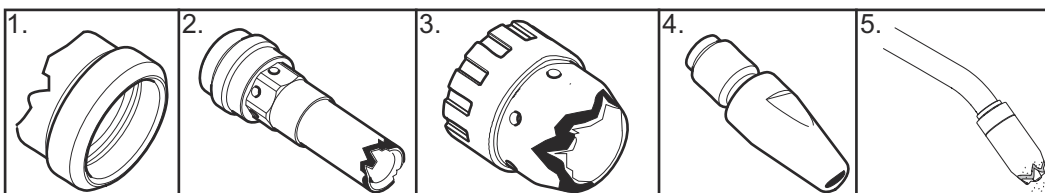

1. Éléments d'isolation
 - bords extérieurs brûlés, rainures
2. Porte-buses
 - bords extérieurs brûlés, rainures
 - présence de projections de soudure excessives
3. Protection anti-projections
 - bords extérieurs brûlés, rainures
4. Tubes contact
 - orifices d'entrée et de sortie du fil usés (ovales)
 - présence de projections de soudure excessives
 - brûlures au niveau de l'extrémité avant du tube contact
5. Buses de gaz
 - présence de projections de soudure excessives
 - bords extérieurs brûlés
 - rainures

Maintenance à chaque mise en service

- Contrôler les pièces d'usure
- Remplacer les pièces d'usure défectueuses
- Enlever les projections de soudure qui se trouvent sur la buse de gaz

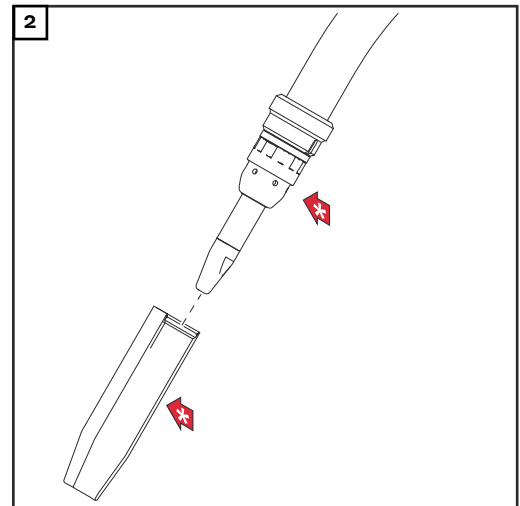
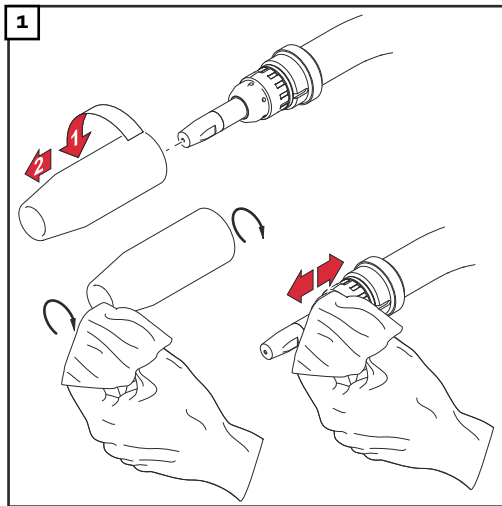

- * Contrôler l'état de la buse de gaz, de la protection anti-projections et des isolations et remplacer les composants endommagés.
- En supplément à chaque mise en service, pour les torches de soudage refroidies par eau :
 - S'assurer que tous les connecteurs de réfrigérant sont étanches
 - Vérifier la présence d'un reflux de réfrigérant conforme

Maintenance à chaque remplacement de la bobine de fil/bobine type panier

- Nettoyer la gaine de dévidoir avec de l'air comprimé à débit réduit
- Recommandé : remplacer l'âme de guidage du fil ; nettoyer les pièces d'usure avant d'installer de nouveau l'âme de guidage du fil.

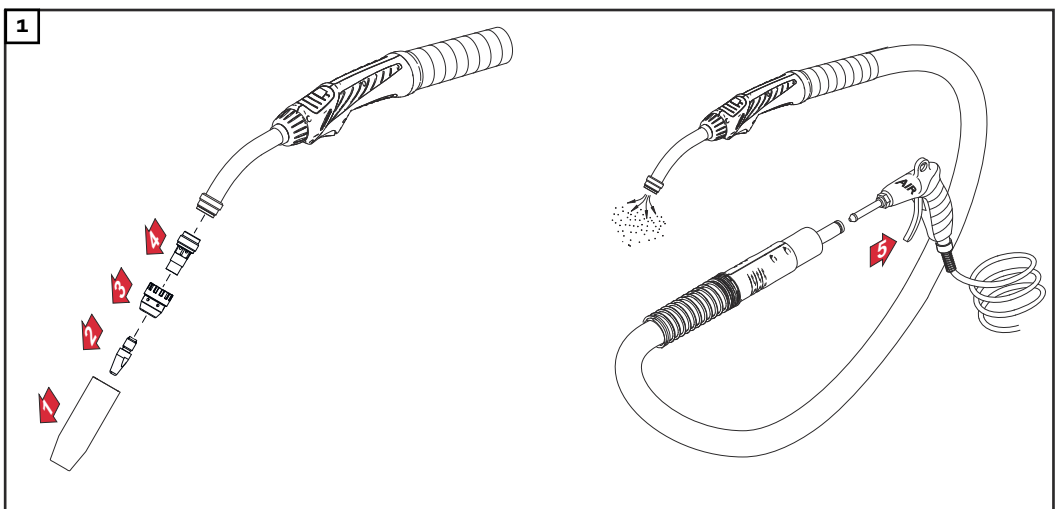

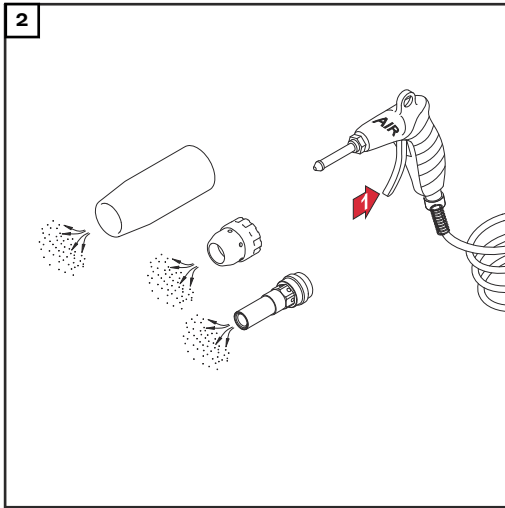

Diagnostic d'erreur, élimination de l'erreur

Diagnostic d'erreur, élimination de l'erreur

Pas de courant de soudage

Interrupteur d'alimentation de la source de courant activé, voyants allumés sur la source de courant, gaz de protection disponible

Cause : Connexion à la masse incorrecte

Solution : Établir le raccordement à la masse de manière conforme

Cause : Câble de courant interrompu dans la torche de soudage

Solution : Remplacer la torche de soudage

Pas de fonction après avoir appuyé sur la gâchette de la torche de soudage

Interrupteur d'alimentation de la source de courant activé, voyants allumés sur la source de courant

Cause : FSC (« Fronius System Connector » - raccord central) non raccordé jusqu'en butée

Solution : Insérer le Fronius System Connector jusqu'à la butée

Cause : Torche de soudage ou câble de commande de la torche de soudage défectueux

Solution : Remplacer la torche de soudage

Cause : Faisceau de liaison non raccordé correctement ou défectueux

Solution : Raccorder correctement le faisceau de liaison
Remplacer le faisceau de liaison défectueux

Cause : Source de courant défectueuse

Solution : Contacter le service après-vente

Pas de gaz de protection

Toutes les autres fonctions sont disponibles

Cause : Bouteille de gaz vide

Solution : Remplacer la bouteille de gaz

Cause : Robinet détendeur défectueux

Solution : Remplacer le robinet détendeur

Cause : Le tuyau de gaz n'est pas monté, est plié ou est endommagé

Solution : Monter, poser de manière plus rectiligne le tuyau de gaz. Remplacer le tuyau de gaz défectueux

Cause : Torche de soudage défectueuse

Solution : Remplacer la torche de soudage

Cause : Électrovanne de gaz défectueuse

Solution : Contacter le service après-vente (faire remplacer l'électrovanne de gaz)

Mauvaises caractéristiques de soudage

Cause : Paramètres incorrects

Solution : Corriger les paramètres

Cause : connexion de mise à la masse incorrecte.

Solution : Établir un bon contact avec la pièce à souder

Cause : Pas ou pas assez de gaz de protection

Solution : Vérifier le robinet détendeur, le tuyau de gaz, l'électrovanne de gaz et le raccord de gaz de protection de la torche de soudage Dans le cas des torches AL, vérifier l'étanchéité au gaz et utiliser une gaine guide-fil adaptée

Cause : fuite au niveau de la torche de soudage.

Solution : Remplacer la torche de soudage

Cause : Tube contact trop grand ou usé

Solution : Remplacer le tube contact

Cause : Mauvais alliage ou mauvais diamètre du fil

Solution : Contrôler la bobine de fil/bobine type panier insérée

Cause : Mauvais alliage ou mauvais diamètre du fil

Solution : Vérifier la compatibilité du matériau de base avec le soudage

Cause : Gaz de protection inapproprié pour cet alliage de fil

Solution : Utiliser le bon gaz de protection

Cause : Conditions de soudage défavorables : gaz de protection contaminé (humidité, air), blindage gaz défectueux (bain de fusion "en ébullition", courant d'air), impuretés dans la pièce à usiner (rouille, peinture, graisse)

Solution : Optimiser les conditions de soudage

Cause : Du gaz de protection s'échappe du raccord de serrage

Solution : Utiliser un raccord de serrage adapté

Cause : Rondelle d'étanchéité du raccord de serrage défectueuse, du gaz de protection s'échappe du raccord de serrage

Solution : Remplacer le raccord de serrage pour assurer l'étanchéité au gaz

Cause : Projections de soudure dans la buse de gaz

Solution : Enlever les projections de soudure

Cause : Turbulences dues à une trop grande quantité de gaz de protection

Solution : Réduire la quantité de gaz de protection, recommandation :
quantité de gaz de protection (l/min) = diamètre du fil (mm) x 10
(par ex. 16 l/min pour un fil-électrode de 1,6 mm)

Cause : Distance trop grande entre la torche de soudage et la pièce à souder

Solution : Réduire la distance entre la torche de soudage et la pièce à souder
(env. 10 - 15 mm/0.39 - 0.59 in.)

Cause : Angle de placement de la torche de soudage trop grand

Solution : Réduire l'angle de placement de la torche de soudage

Cause : Les composants du dévidoir ne correspondent pas au diamètre du fil-électrode / au matériau du fil-électrode

Solution : Utiliser des composants de déplacement du fil appropriés

Avance du fil défectueuse

Cause : Selon le système, le réglage du frein du dévidoir ou de la source de courant est trop serré

Solution : Régler le frein moins fort

Cause : L'orifice du tube contact est obturé

Solution : Remplacer le tube contact

Cause : Gaine guide-fil ou système de guidage du fil défectueux

Solution : Vérifier que la gaine guide-fil ou l'embout de guide-fil n'est ni plié(e), ni encrassé(e), etc.

Remplacer la gaine guide-fil défectueuse ou l'embout de guide-fil défectueux

Cause : Les galets d'entraînement ne sont pas adaptés au fil-électrode utilisé

Solution : Utiliser des galets d'entraînement adaptés

Cause : Pression d'appui des galets d'entraînement incorrecte

Solution : Optimiser la pression d'appui

Cause : Galets d'entraînement encrassés ou endommagés

Solution : Nettoyer ou remplacer les galets d'entraînement

Cause : Gaine guide-fil obturée ou pliée

Solution : Remplacer la gaine guide-fil

Cause : Gaine guide-fil trop courte après égalisation

Solution : Remplacer la gaine guide-fil et couper la nouvelle à la bonne longueur

Cause : Abrasion du fil-électrode en raison d'une pression d'appui trop élevée au niveau des galets d'entraînement

Solution : Réduire la pression d'appui au niveau des galets d'entraînement

Cause : Fil-électrode encrassé ou rouillé

Solution : Utiliser un fil-électrode de plus grande qualité, sans impureté

Cause : Pour une gaine guide-fil en acier, utilisation d'une gaine guide-fil sans revêtement

Solution : Utiliser une gaine guide-fil avec revêtement

Cause : Zones d'entrée et de sortie du fil du raccord de serrage déformées (ovales, déformées), du gaz de protection s'échappe du raccord de serrage

Solution : Remplacer le raccord de serrage pour assurer l'étanchéité au gaz

La buse de gaz devient très chaude

Cause: Pas de dissipation thermique en raison d'une fixation trop lâche de la buse de gaz

Remède: Visser la buse de gaz jusqu'à la butée

La torche de soudage devient très chaude

Cause : Sur les torches de soudage Multilock uniquement : Écrou-raccord du corps de torche de soudage desserré

Solution : Serrer l'écrou-raccord

Cause : La torche de soudage a été utilisée au-delà de l'intensité de soudage maximale

Solution : Baisser la puissance de soudage ou utiliser une torche de soudage plus puissante

Cause : Torche de soudage insuffisamment dimensionnée

Solution : Respecter le facteur de marche et les limites de charge

Cause : Uniquement pour les installations refroidies par eau : Débit de réfrigérant trop faible

Solution : Contrôler le niveau de réfrigérant, le volume du débit de réfrigérant, l'encrassement du réfrigérant, la pose du faisceau de liaison, etc.

Cause : L'extrémité de la torche de soudage est trop proche de l'arc électrique

Solution : Augmenter le Stickout

Courte durée de vie du tube contact

Cause : Galets d'entraînement non adaptés

Solution : Utiliser des galets d'entraînement adaptés

Cause : Abrasion du fil-électrode en raison d'une pression d'appui trop élevée au niveau des galets d'entraînement

Solution : Réduire la pression d'appui au niveau des galets d'entraînement

Cause : Fil-électrode encrassé/rouillé

Solution : Utiliser un fil-électrode de plus grande qualité, sans impureté

Cause : Fil-électrode non-revêtu

Solution : Utiliser un fil-électrode disposant du revêtement approprié

Cause : Mauvaise dimension du tube contact

Solution : Dimensionner correctement le tube contact

Cause : Facteur de marche de la torche de soudage trop long

Solution : Diminuer le facteur de marche ou utiliser une torche de soudage plus puissante

Cause : Surchauffe du tube contact. Pas de dissipation thermique en raison d'une fixation trop lâche du tube contact

Solution : Visser le tube contact

REMARQUE!

Dans le cas des applications CrNi, l'usure du tube contact peut être plus importante en raison de la composition de la surface du fil-électrode CrNi.

Dysfonctionnement de la gâchette de la torche

Cause : La connexion entre la torche de soudage et la source de courant est défectueuse

Solution : Établir les connexions de manière conforme / adresser la source de courant ou la torche de soudage au S.A.V.

Cause : Présence d'impuretés entre la gâchette de torche et son boîtier

Solution : Procéder au nettoyage

Cause : Câble de commande défectueux

Solution : Contacter le service après-vente

Porosité de la soudure

Cause : Formation de projections dans la buse de gaz, d'où une protection gazeuse insuffisante de la soudure

Solution : Enlever les projections de soudure

Cause : Présence de trous dans le tuyau de gaz ou raccordement incorrect du tuyau de gaz

Solution : Remplacer le tuyau de gaz

Cause : Le joint torique du raccord central est entaillé ou défectueux

Solution : Remplacer le joint torique

Cause : Humidité/condensation dans la conduite de gaz

Solution : Sécher la conduite de gaz

Cause : Débit de gaz trop fort ou trop faible

Solution : Corriger le débit de gaz

Cause : Quantité de gaz insuffisante au début ou à la fin du soudage

Solution : Augmenter le prédébit de gaz et le post-débit de gaz

Cause : Fil-électrode rouillé ou de mauvaise qualité

Solution : Utiliser un fil-électrode de plus grande qualité, sans impureté

Cause : S'applique aux torches AL : Sortie de gaz sur des âmes de guidage du fil non isolées

Solution : Pour les torches AL, n'utiliser que des âmes de guidage du fil isolées

Cause : Agent de séparation en quantité excessive

Solution : Enlever l'agent de séparation en excès/ Appliquer moins d'agent de séparation

Cause : Aspiration trop puissante

Solution : Réduire l'aspiration

Puissance d'aspiration trop faible

Cause : Présence de trous dans le tuyau d'aspiration

Solution : Remplacer le tuyau d'aspiration

Cause : Filtre usé

Solution : Remplacer le filtre de l'appareil d'aspiration

Cause : Voie d'aspiration obstruée

Solution : Éliminer les obstructions

Cause : Puissance d'aspiration de l'appareil d'aspiration trop faible ; mauvaise configuration de l'OPT/i FumeEx

Solution : Régler l'appareil d'aspiration sur une puissance d'aspiration plus forte ;
augmenter la puissance d'aspiration

Caractéristiques techniques

Généralités

Mesure de la tension (V-Peak) :

- pour torches de soudage manuelles : 113 V
- pour torches de soudage à guidage mécanique : 141 V



Caractéristiques techniques de la gâchette de la torche :

- $U_{max} = 5 \text{ V}$
- $I_{max} = 10 \text{ mA}$

L'utilisation de la gâchette de la torche est uniquement autorisée dans le cadre des caractéristiques techniques.

Ce produit satisfait aux exigences de la norme IEC 60974-7 / - 10 CI. A.

Torche de soudage refroidi par gaz - MTG 250d - 500d

	MTG 250d	MTG 320d	MTG 400d	MTG 500d
I (Amp.) 10 min/ 40 °C CO ²	40 % f.m.* 250 60 % f.m.* 200 100 % f.m.* 170	40 % f.m.* 320 60 % f.m.* 260 100 % f.m.* 210	40 % f.m.* 400 60 % f.m.* 320 100 % f.m.* 260	40 % f.m.* 500 60 % f.m.* 400 100 % f.m.* 320
I (Amp.) 10 min/ 40 °C M21	40 % f.m.* 200 60 % f.m.* 160 100 % f.m.* 120	40 % f.m.* 260 60 % f.m.* 210 100 % f.m.* 160	40 % f.m.* 320 60 % f.m.* 260 100 % f.m.* 210	40 % f.m.* 400 60 % f.m.* 320 100 % f.m.* 260
 [mm (in.)]	0,8-1,2 (.032-.047)	0,8-1,6 (.032-.063)	1,0-1,6 (.039-.063)	1,0-1,6 (.039-.063)
 [m (ft.)]	3,5 / 4,5 (12 / 15)	3,5 / 4,5 (12 / 15)	3,5 / 4,5 (12 / 15)	3,5 / 4,5 (12 / 15)

* f.m. = facteur de marche

Col de cygne refroidi par gaz – MTB 250i, 320i, 330i, 400i, 550i G ML

	MTB 250i G ML	MTB 320i G ML	MTB 330i G ML
I (Ampère) 10 min/ 40 °C M21+C1 (EN 439)	40 % ED* 250 60 % ED* 200 100 % ED* 170	40 % ED* 320 60 % ED* 260 100 % ED* 210	40 % ED* 330 60 % ED* 270 100 % ED* 220
 [mm (in.)]	0,8 à 1,2 (.032 à .047)	0,8 à 1,6 (.032 à .063)	0,8 à 1,6 (.032 à .063)



* ED = facteur de marche

	MTB 400i G ML	MTB 550i G ML
I (Ampère) 10 min/ 40 °C C1 (EN 439)	-	30 % ED* 550

	MTB 400i G ML	MTB 550i G ML
I (Ampère) 10 min/ 40 °C M21 (EN 439)	-	30 % ED* 520
I (Ampère) 10 min/ 40 °C M21+C1 (EN 439)	40 % ED* 400 60 % ED* 320 100 % ED* 260	- 60 % ED* 420 100 % ED* 360
 [mm (in.)]	0,8 à 1,6 (.032 à .063)	0,8 à 1,6 (.032 à .063)



* ED = facteur de marche

Faisceau de liaison refroidi par gaz - MHP 400d G ML

	MHP 400d G ML
I (Ampère) 10 min/40° C CO ²	40 % f.m.* 400 60 % f.m.* 320 100 % f.m.* 260
I (Ampère) 10 min/40° C M21	40 % f.m.* 320 60 % f.m.* 260 100 % f.m.* 210
 [mm (in.)]	0,8-1,6 (.032-.063)
 [m (ft.)]	3,35 / 4,35 (11 / 14)

* f.m. = facteur de marche







Faisceau de liaison refroidi par gaz - MHP 500d G ML M

	MHP 500d G ML M
I (Amp.) 10 min/40 °C CO ²	40 % f.m.* 500 60 % f.m.* 400 100 % f.m.* 320
I (Amp.) 10 min/40 °C M21	40 % f.m.* 400 60 % f.m.* 320 100 % f.m.* 260
 [mm (in.)]	0,8-1,6 (.032-.063)
 [m (ft.)]	1,35 / 2,35 / 3,35 (4.4 / 7.7 / 14)

* f.m. = facteur de marche

Torche de soudage refroidi par eau - MTW 250d - 700d



	MTW 250d	MTW 400d	MTW 500d	MTW 700d
I (Ampère) 10 min/ 40 °C CO ²	100 % f.m.* 250	100 % f.m.* 400	100 % f.m.* 500	100 % f.m.* 700

	MTW 250d	MTW 400d	MTW 500d	MTW 700d
I (Ampère) 10 min/ 40 °C M21	100 % f.m. 200	100 % f.m. 320	100 % f.m. 400	100 % f.m. 560
 [mm (in.)]	0,8-1,2 (.032-.047)	0,8-1,6 (.032-.063)	0,8-1,6 (.032-.063)	0,8-1,6 (.032-.063)
Q _{min}  [l/min (gal./ min)]	1 (.26)	1 (.26)	1 (.26)	1 (.26)
P _{min}  [W]**	500 (3,5 m) 600 (4,5 m)	800 (3,5 m) 950 (4,5 m)	1400 (3,5 m) 1700 (4,5 m)	1800 (3,5 m) 2200 (4,5 m)
P _{min}  [bar (psi.)]	3 (43)	3 (43)	3 (43)	3 (43)
P _{max}  [bar (psi.)]	5 (72)	5 (72)	5 (72)	5 (72)
 [m (ft.)]	3,5 / 4,5 (12 / 15)	3,5 / 4,5 (12 / 15)	3,5 / 4,5 (12 / 15)	3,5 / 4,5 (12 / 15)



* f.m. = facteur de marche

** Puissance de refroidissement minimale conformément à la norme IEC 60974-2

**Col de cygne re-
froidi par eau –
MTB 250i, 330i,
400i, 500i, 700i
W ML**







	MTB 250i W ML	MTB 330i W ML	MTB 400i W ML	MTB 500i W ML
I (Ampère) 10 min/ 40 °C M21+C1 (EN 439)	100 % ED* 250	100 % ED* 330	100 % ED* 400	100 % ED* 500
 [mm (in.)]	0,8 à 1,2 (.032 à .047)	0,8 à 1,6 (.032 à .063)	0,8 à 1,6 (.032 à .063)	1,0 à 1,6 (.039 à .063)
Q _{min}  [l/min (gal./min)]	1 (.26)	1 (.26)	1 (.26)	1 (.26)

* ED = facteur de marche

	MTB 700i W ML
I (Ampère) 10 min/ 40 °C M21+C1 (EN 439)	100 % ED* 700
 [mm (in.)]	1,0 à 1,6 (.039 à .063)
Q _{min}  [l/min (gal./min)]	1 (.26)

* ED = facteur de marche







Faisceau de liaison refroidi par eau - MHP 500d, 700d W ML

	MHP 500d W ML	MHP 700d W ML
I (Ampère) 10 min/40 °C CO ²	100 % f.m.* 500	100 % f.m.* 700
I (Ampère) 10 min/40 °C M21	100 % f.m.* 400	100 % f.m.* 560
 [mm (in.)]	0,8-1,6 (.032-.063)	0,8-1,6 (.032-.063)
 [m (ft.)]	3,35 / 4,35 (11 / 14)	3,35 / 4,35 (11 / 14)
P _{min}  [W]**	1400 / 1700	1800 / 2200
Q _{min}  [l/min (gal./min.)]	1 (.26)	1 (.26)
P _{min}  [bar (psi.)]	3 (43)	3 (43)
P _{max}  [bar (psi.)]	5 (72)	5 (72)

* f.m. = facteur de marche

** Puissance de refroidissement minimale conformément à la norme IEC 60974-2



Faisceau de liaison refroidi par eau - MHP 700d W ML M

	MHP 700d W ML M
I (Ampère) 10 min/40 °C CO ²	100 % f.m.* 700
I (Ampère) 10 min/40 °C M21	100 % f.m.* 560
 [mm (in.)]	0,8-1,6 (.032-.063)
 [m (ft.)]	1,35 / 2,35 / 3,35 (4.4 / 7.7 / 14)
P _{min}  [W]**	1100 / 1450 / 1800
Q _{min}  [l/min (gal./min.)]	1 (.26)
P _{min}  [bar (psi.)]	3 (43)
P _{max}  [bar (psi.)]	5 (72)

* f.m. = facteur de marche

** Puissance de refroidissement minimale conformément à la norme IEC 60974-2



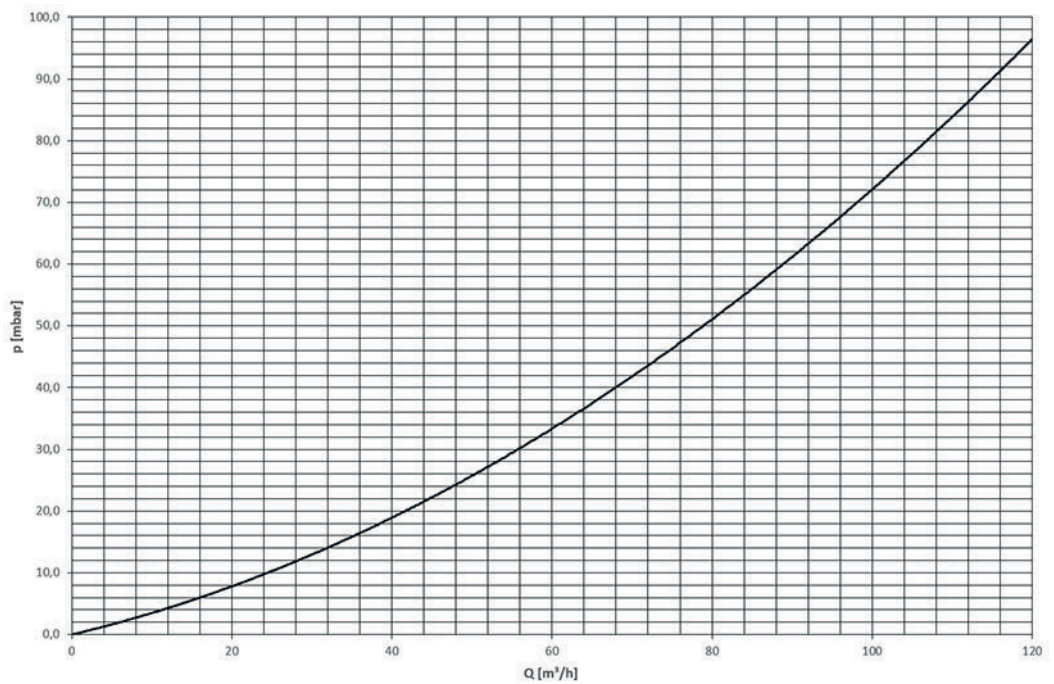

MTG 400d K4

		MTG 400d K4
I (ampère) 10 min/40 °C CO ₂ /mixed		40 % f.m.* 400 60 % f.m.* 320 100 % f.m.* 260
 [mm (in.)]		0,8 à 1,6 (.032-.063)
 [m (ft.)]		4,5 (15)

* f.m. = facteur de marche

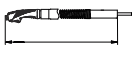
**Caractéristique
d'aspiration
MTG 400d K4**

MTW 500d K4

		MTW 500d K4
I (ampère) 10 min/40 °C CO ₂ /mixed		100 % f.m.* 500
 [mm (in.)]		0,8-1,6 (.032-.063)
 [m (ft.)]		4,5 (15)
P _{max}  [W]**		1700
Q _{min}  [l/min (gal./min)]		1 (26)
P _{min}  [bar (psi.)]		3 (43)
P _{max}  [bar (psi.)]		5 (72)

* f.m. = facteur de marche

** Puissance de refroidissement minimale conformément à la norme CEI 60974-2

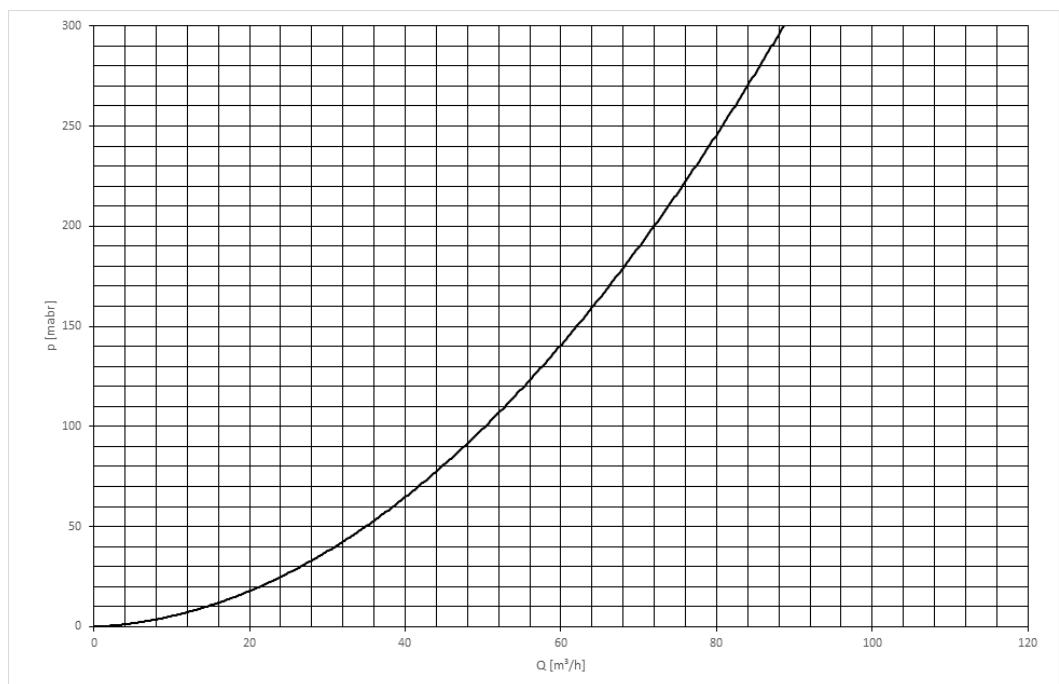
**Caractéristique
d'aspiration
MTW 500d K4**

Indice

Sicurezza	140
Usò prescritto.....	140
Sicurezza	140
I fumi di saldatura	141
MTG d, MTW d, MHP d - In generale	142
Funzione Up/Down.....	142
Funzione JobMaster.....	142
MTG 400d K4, MTW 500d K4 - In generale	144
In generale	144
Valori indicativi per gli aspiratori.....	144
Regolatore del flusso dell'aria	144
Funzione Up/Down.....	145
Montaggio dei pezzi soggetti a usura sul corpo della torcia	146
MTG d, MTW d - Montaggio dei pezzi soggetti ad usura sul corpo della torcia.....	146
MTG 400d K4, MTW 500d K4 - Montaggio dei pezzi soggetti ad usura	146
Montaggio del corpo della torcia ML sul pacchetto tubi flessibili MHP.....	148
Assemblaggio della torcia per saldatura Multilock	148
Montaggio delle guaine guidafile	149
Controllo del nipplo di serraggio	149
Montaggio della guaina guidafile in acciaio.....	149
Montaggio della guaina guidafile in plastica (F, F++).....	151
Montaggio della guaina in plastica (attacco Fronius con ugello per guaina guidafile).....	152
Montaggio della guaina guidafile in plastica (Euro).....	153
Messa in funzione.....	154
Collegamento della torcia per saldatura.....	154
Collegamento dell'aspirazione	154
Rotazione del corpo torcia della torcia per saldatura Multilock.....	155
Sostituzione del corpo torcia della torcia per saldatura Multilock	156
Supporto con profilo sagomato per torcia per saldatura a macchina.....	157
Cura e manutenzione.....	158
In generale	158
Riconoscimento dei pezzi soggetti ad usura difettosi.....	158
Manutenzione a ogni messa in funzione.....	158
Manutenzione ad ogni sostituzione della bobina filo/bobina intrecciata.....	159
Diagnosi e risoluzione degli errori.....	161
Diagnosi e risoluzione degli errori.....	161
Dati tecnici	167
In generale	167
Torcia per saldatura raffreddato a gas - MTG 250d-500d.....	167
Corpo della torcia raffreddato a gas - MTB 250i, 320i, 330i, 400i, 550i G ML.....	167
Pacchetto tubi flessibili raffreddato a gas - MHP 400d G ML.....	168
Pacchetto tubi flessibili raffreddato a gas - MHP 500d G ML M.....	168
Torcia per saldatura raffreddato ad acqua - MTW 250d-700d.....	168
Corpo della torcia raffreddato ad acqua - MTB 250i, 330i, 400i, 500i, 700i W ML.....	169
Pacchetto tubi flessibili raffreddato ad acqua - MHP 500d, 700d W ML	169
Pacchetto tubi flessibili raffreddato ad acqua - MHP 700d W ML M.....	170
MTG 400d K4.....	171
Curva caratteristica di aspirazione MTG 400d K4.....	171
MTW 500d K4.....	172
Curva caratteristica di aspirazione MTW 500d K4.....	172

Sicurezza

Uso prescritto

La torcia per saldatura manuale MIG/MAG è destinata esclusivamente alla saldatura MIG/MAG nelle applicazioni manuali.

Non sono consentiti utilizzi diversi o che esulino dal tipo d'impiego per il quale l'apparecchio è stato progettato. Il produttore non si assume alcuna responsabilità per i danni che potrebbero derivarne.

L'uso prescritto comprende anche

- l'osservanza di tutte le avvertenze riportate nelle istruzioni per l'uso
 - l'esecuzione dei controlli e dei lavori di manutenzione.
-

Sicurezza

PERICOLO!

Il cattivo uso dell'apparecchio e l'esecuzione errata dei lavori

possono causare gravi lesioni personali e danni materiali.

- ▶ Tutti i lavori e le funzioni descritti nel presente documento devono essere eseguiti soltanto da personale tecnico qualificato.
 - ▶ Leggere integralmente e comprendere il presente documento.
 - ▶ Leggere e comprendere tutte le norme di sicurezza e le documentazioni per l'utente di questo apparecchio e di tutti i componenti del sistema.
-

PERICOLO!

La corrente elettrica

può causare gravi lesioni personali e danni materiali.

- ▶ Prima di iniziare qualsiasi lavoro, spegnere e scollegare dalla rete elettrica tutti gli apparecchi e i componenti interessati.
 - ▶ Assicurarsi che gli apparecchi e i componenti interessati non vengano riaccesi.
-

PERICOLO!

La corrente elettrica dovuta a componenti del sistema difettosi e il cattivo uso dell'apparecchio

possono causare gravi lesioni personali e danni materiali.

- ▶ Tutti i cavi, i conduttori e i pacchetti tubi flessibili devono sempre essere saldamente collegati, integri e correttamente isolati.
 - ▶ Utilizzare solo cavi, conduttori e pacchetti tubi flessibili adeguatamente dimensionati.
-

PERICOLO!

Lo scivolamento dovuto alla fuoriuscita di refrigerante

può causare gravi lesioni personali e danni materiali.

- ▶ Quando vengono scollegati dal gruppo di raffreddamento o da altri componenti del sistema, chiudere sempre i tubi del refrigerante delle torce per saldatura raffreddate ad acqua con la chiusura in plastica montata su di essi.
-

 **PERICOLO!**

Componenti del sistema e/o mezzi operativi surriscaldati

possono causare gravi ustioni.

- ▶ Prima di iniziare qualsiasi lavoro, far raffreddare tutti i componenti del sistema e/o i mezzi operativi a +25 °C / +77 °F (ad esempio il refrigerante, i componenti del sistema raffreddati ad acqua, il motore di azionamento del carrello traina filo, ecc.).
- ▶ Se non è possibile farli raffreddare, indossare dispositivi di protezione adeguati (ad esempio guanti protettivi resistenti al calore, occhiali protettivi, ecc.).

 **PERICOLO!**

Pericolo dovuto al contatto con fumi di saldatura tossici.

Possono conseguirne gravi lesioni personali.

- ▶ Estrarre sempre i fumi di saldatura.
- ▶ Predisporre un'alimentazione di aria pura sufficiente. Assicurarsi che vi sia sempre un tasso di aerazione di almeno 20 m³ (169070.1 US gi) all'ora.
- ▶ In caso di dubbi, far accertare il carico di inquinanti nella postazione di lavoro da un tecnico esperto in sicurezza.

 **PRUDENZA!**

Il funzionamento senza refrigerante

può causare danni materiali.

- ▶ Non azionare mai gli apparecchi senza refrigerante.
- ▶ Durante la saldatura, assicurarsi che il refrigerante fluisca correttamente (se si utilizzano gruppi di raffreddamento Fronius, il refrigerante fluisce correttamente quando si vede il refrigerante rifluire correttamente nel serbatoio del refrigerante del gruppo di raffreddamento).
- ▶ Il produttore non si assume alcuna responsabilità per i danni causati dall'inosservanza dei punti di cui sopra ed esclude ogni ricorso alla garanzia per questo tipo di danni.

I fumi di saldatura

 **PERICOLO!**

prodotti dal processo di saldatura contengono gas e vapori dannosi per la salute che possono causare gravi danni alla salute.

- ▶ Non è consentito eseguire saldature senza aspiratori accesi.
- ▶ In alcune circostanze, l'uso delle sole torce aspiranti può non bastare. In questi casi, installare un'aspirazione aggiuntiva per ridurre il carico di inquinanti nella postazione di lavoro.
- ▶ In caso di dubbi, far accertare il carico di inquinanti nella postazione di lavoro da un tecnico esperto in sicurezza.

MTG d, MTW d, MHP d - In generale

Funzione Up/Down

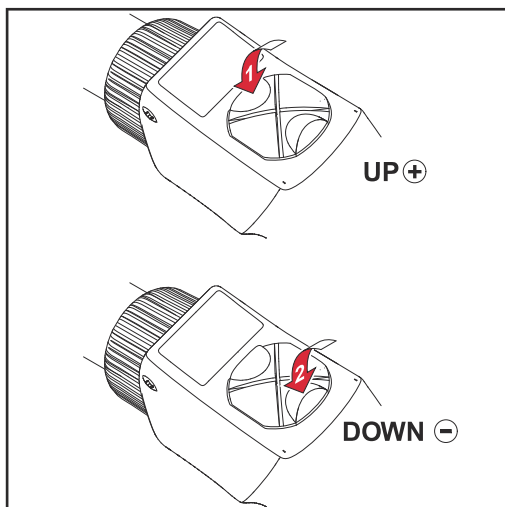

- Sul generatore, selezionare uno dei seguenti parametri:
 - Velocità filo
 - Numero Job
- Impostare il parametro mediante la funzione Up/Down.

IMPORTANTE! Nelle modalità di funzionamento "Saldatura Synergic Standard e Pulse MIG/MAG" è possibile impostare ulteriori parametri.

Funzione Job-Master

IMPORTANTE! JobMaster consente di visualizzare messaggi mediante codici. Essi corrispondono al codice di servizio contemporaneamente visualizzato sul pannello di controllo (vedere le istruzioni per l'uso del generatore, capitolo "Diagnosi e risoluzione degli errori").

SynchroPuls (opzione) - su JobMaster non si accende alcun simbolo (vedere le istruzioni per l'uso del generatore, capitolo "Saldatura MIG/MAG").

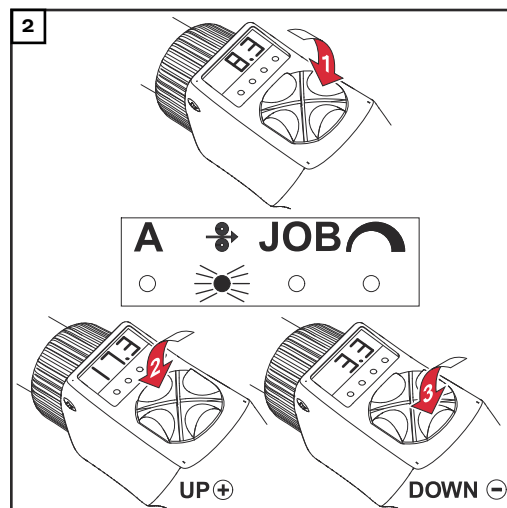
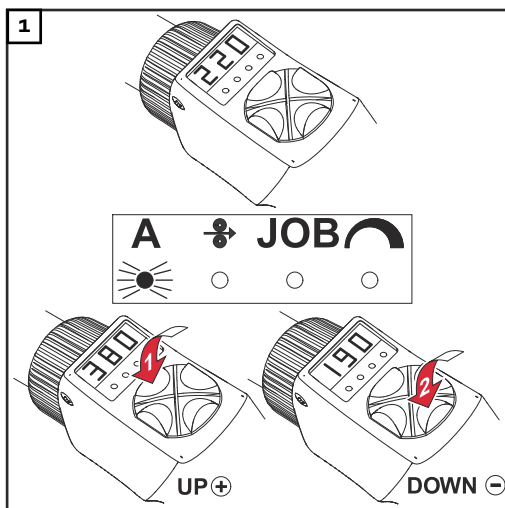

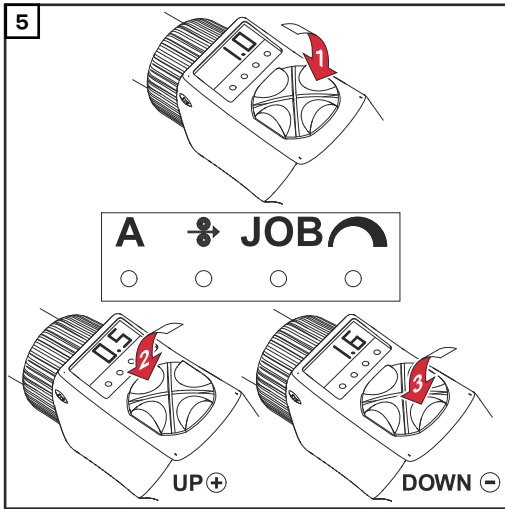
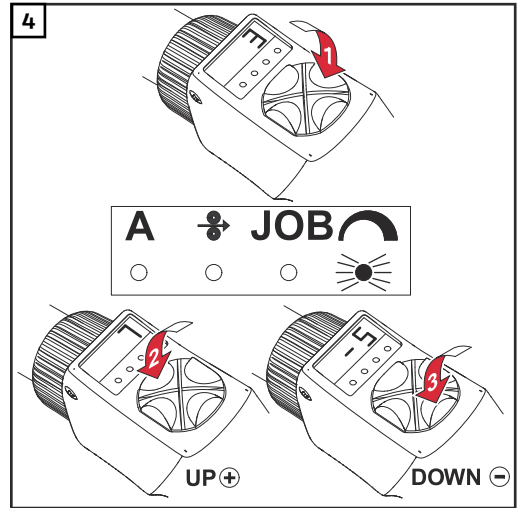
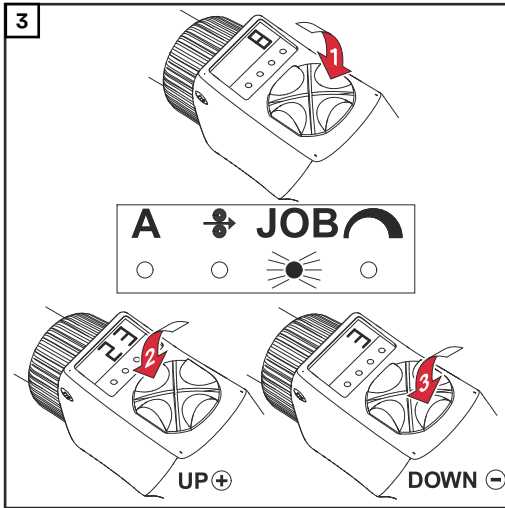

IT

MTG 400d K4, MTW 500d K4 - In generale

In generale

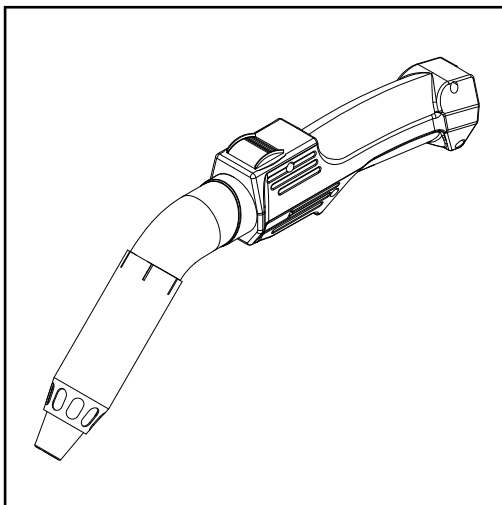

Le torce aspiranti MTG 400d K4 e MTW 500d K4 raccolgono i fumi di saldatura dannosi per la salute prodotti dal processo di saldatura direttamente dove vengono prodotti.

I fumi di saldatura vengono aspirati prima che raggiungano la zona di respirazione del saldatore.

In questo modo, la massima concentrazione ammissibile negli ambienti di lavoro (MAC) risulta pari o inferiore ai valori prescritti per legge.

Valori indicativi per gli aspiratori

L'aspiratore delle torce aspiranti dovrebbe rispondere alle seguenti specifiche:

Potenza di aspirazione

Ca. 100 m³/h

Valori di depressione

Tra 0,05 e 0,2 bar
(tra 5000 e 20000 Pa)

Regolatore del flusso dell'aria

Il regolatore del flusso dell'aria consente di regolare in continuo tra 10% e 100% la quantità di fumi di saldatura aspirati durante il processo di saldatura.

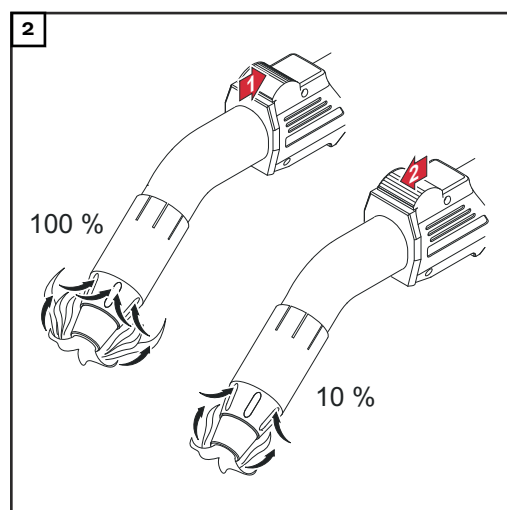
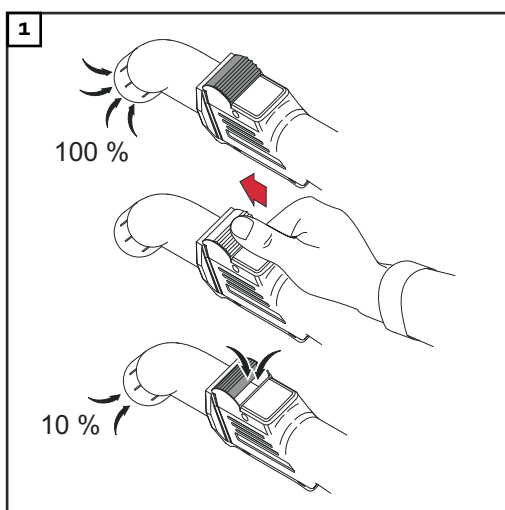

IMPORTANTE! Occorre regolare la quantità di fumi di saldatura aspirati quando insieme ai fumi di saldatura si aspira anche il gas inerte (ad es. durante la saldatura in posizione ad angolo).

**Funzione Up/
Down**

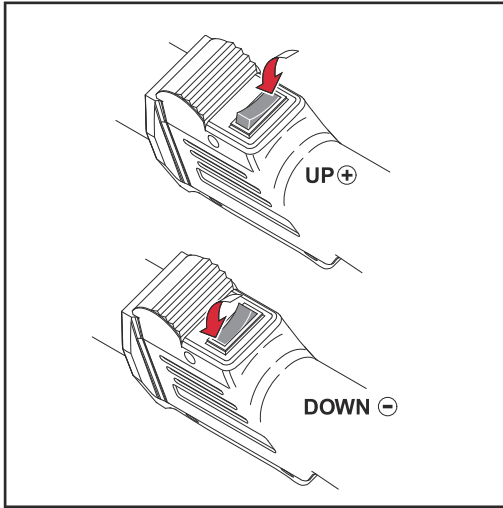

Montaggio dei pezzi soggetti a usura sul corpo della torcia

MTG d, MTW d -
Montaggio dei
pezzi soggetti ad
usura sul corpo
della torcia

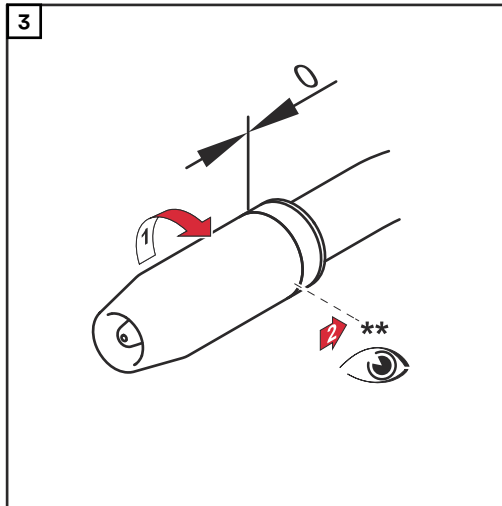
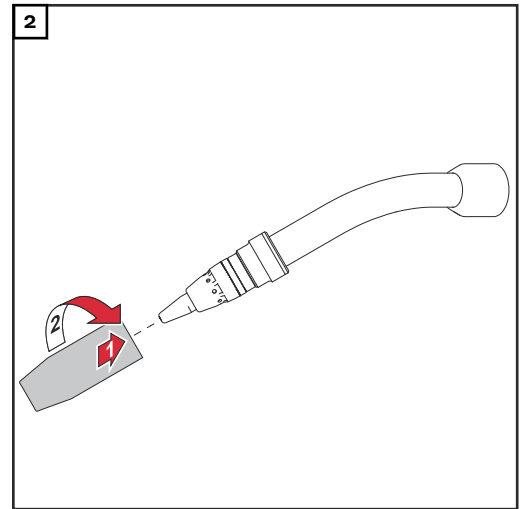
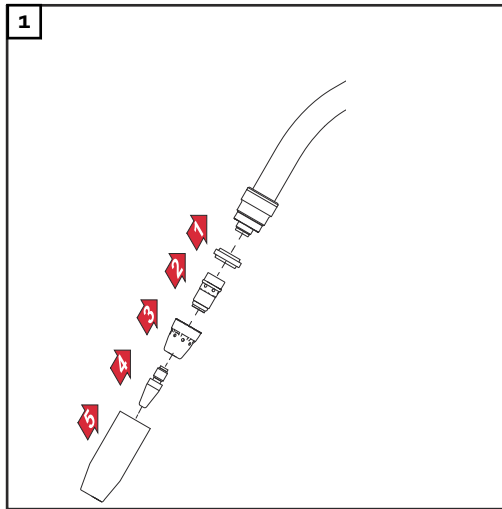

** Serrare completamente l'ugello del gas.

MTG 400d K4,
MTW 500d K4 -
Montaggio dei
pezzi soggetti ad
usura

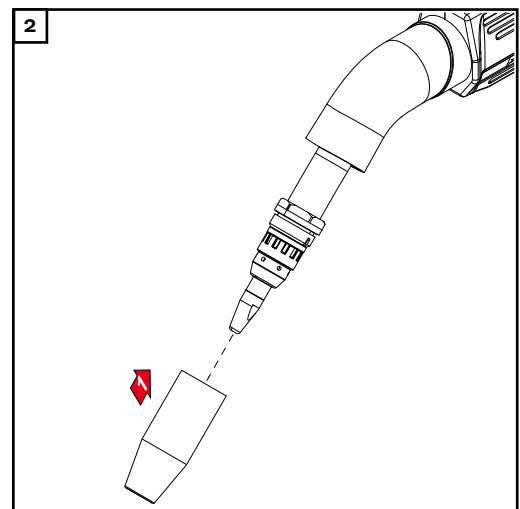
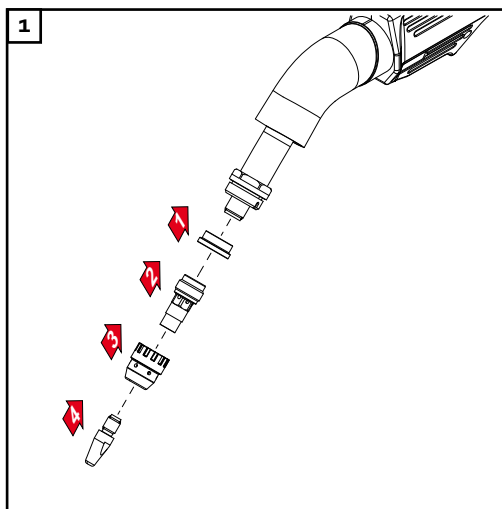

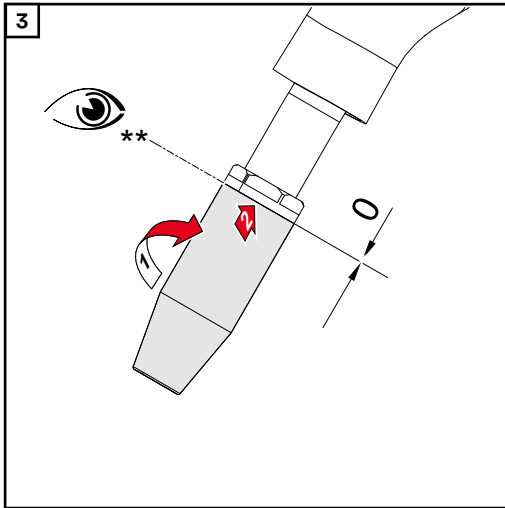

** Serrare completamente l'ugello del gas.

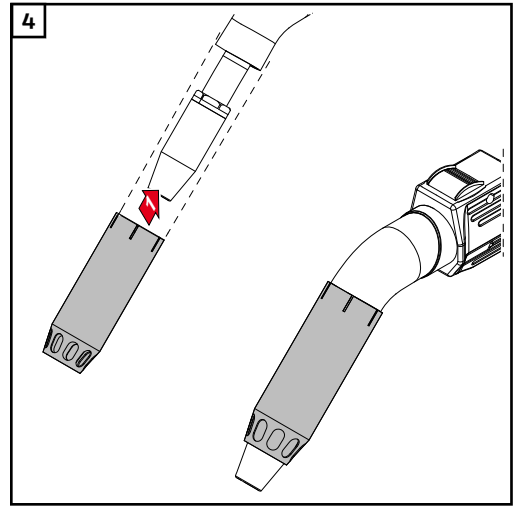

Posizionare l'ugello di aspirazione.

Montaggio del corpo della torcia ML sul pacchetto tubi flessibili MHP

Assemblaggio della torcia per saldatura Multi-lock

AVVERTENZA!

Pericolo di danneggiamento della torcia per saldatura. Serrare sempre completamente il dado per raccordi del corpo torcia.

AVVERTENZA!

Nelle torce per saldatura raffreddate ad acqua, per via della loro struttura, è possibile che si avverta una resistenza maggiore durante il serraggio del dado per raccordi. Questo è normale. Serrare sempre completamente il dado per raccordi del corpo della torcia.

AVVERTENZA!

Prima di montare un corpo della torcia, assicurarsi che il punto di collegamento del corpo della torcia e del pacchetto tubi flessibili sia integro e pulito.

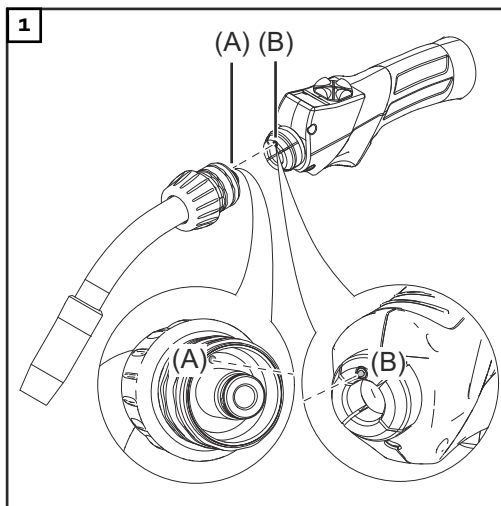

AVVERTENZA!

Quando la spina di registro (A) del pacchetto tubi flessibili si inserisce nel foro di riferimento (B) del corpo della torcia, il corpo torcia è posizionato a 0°.

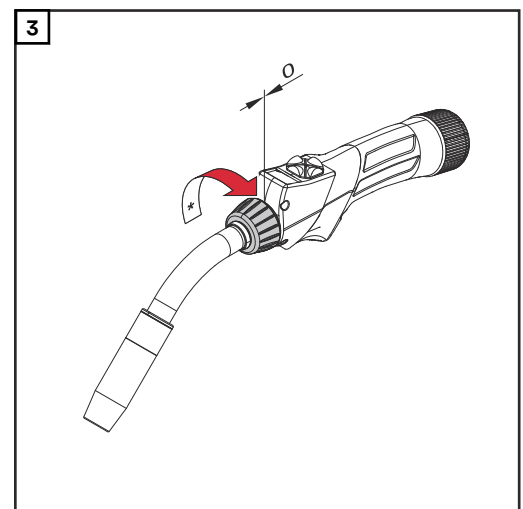
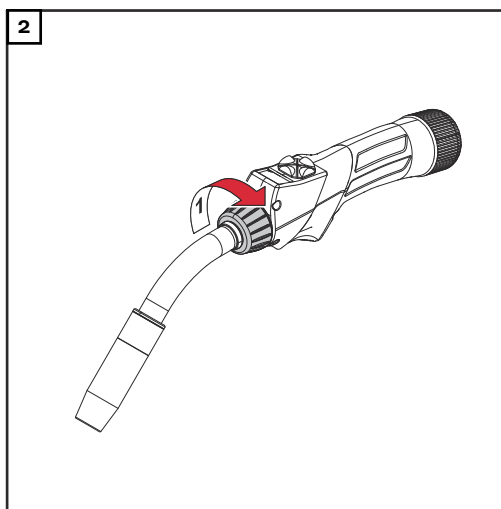

* Assicurarsi che il dado per raccordi sia serrato completamente.

Montaggio delle guaine guidafile

Controllo del nipplo di serraggio

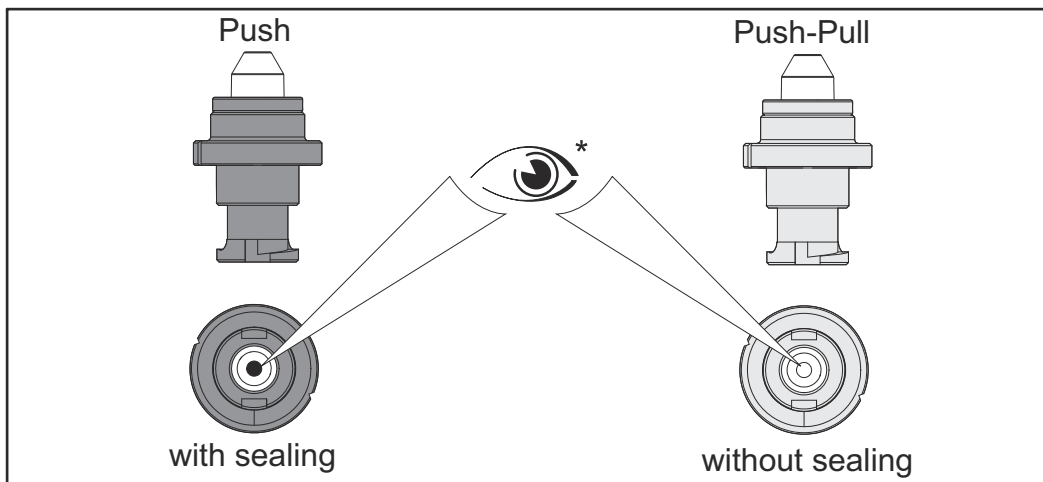

* Controllare il nipplo di serraggio prima della messa in funzione e ad ogni sostituzione della guaina guidafile. A tal fine, eseguire un'ispezione visiva:

- A sinistra: nipplo di serraggio in ottone con disco di tenuta. Non è possibile vedere attraverso il disco di tenuta.
- A destra: nipplo di serraggio in argento con passaggio visibile

AVVERTENZA!

Nipplo di serraggio errato o difettoso nelle applicazioni Push

Può causare fughe di gas e scarse proprietà di saldatura.

- Utilizzare nippoli di serraggio in ottone per ridurre al minimo le fughe di gas.
- Controllare che il disco di tenuta sia integro.

AVVERTENZA!

Nipplo di serraggio errato nelle applicazioni Push-Pull

Può causare l'ingarbugliamento del filo e una maggiore abrasione nella guaina guidafile quando si utilizza un nipplo di serraggio con disco di tenuta.

- Utilizzare nippoli di serraggio in argento per facilitare la guida del filo.

Montaggio della guaina guidafile in acciaio

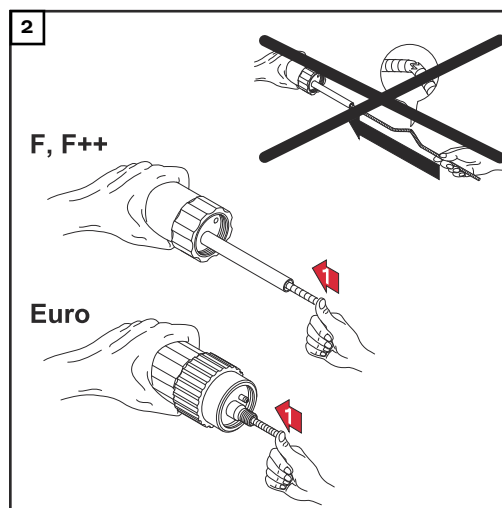
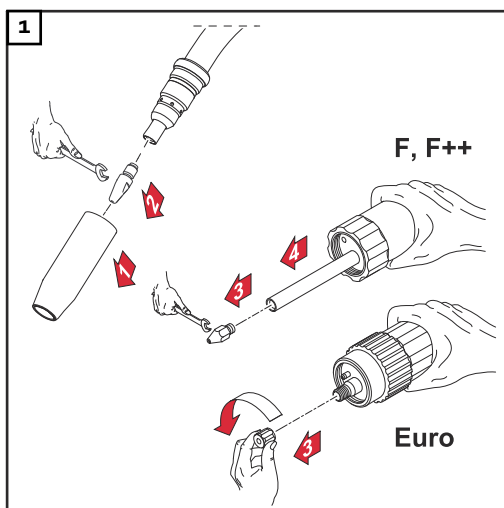

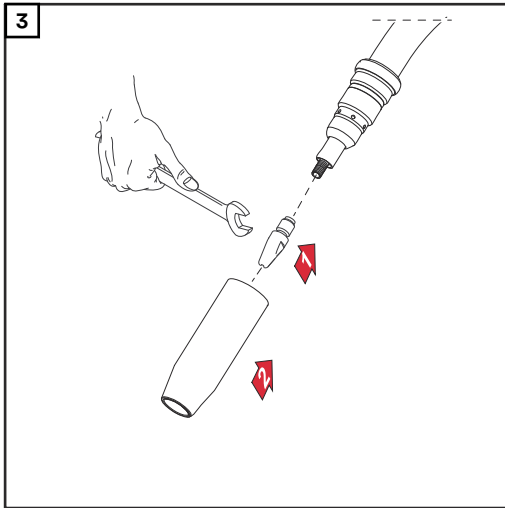

F++, F:

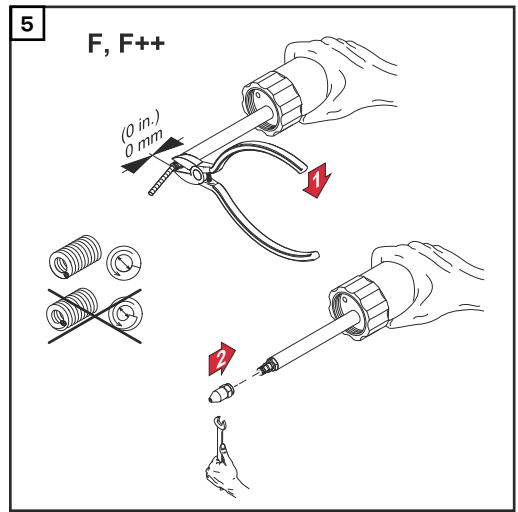
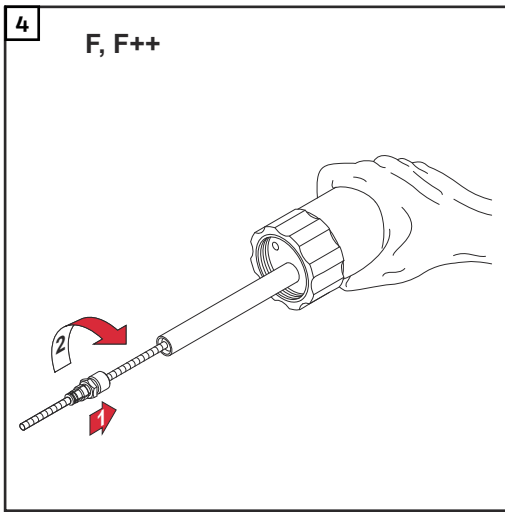

Euro:

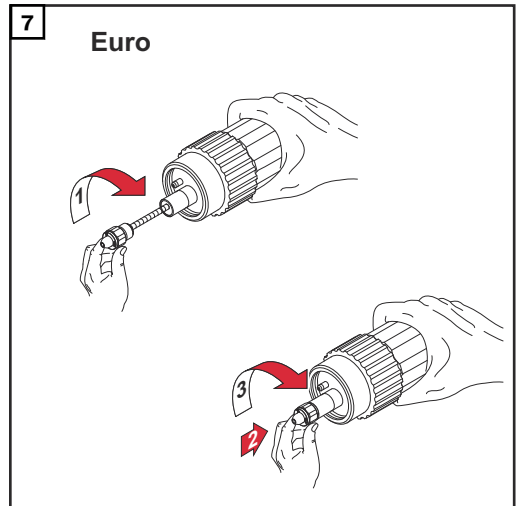
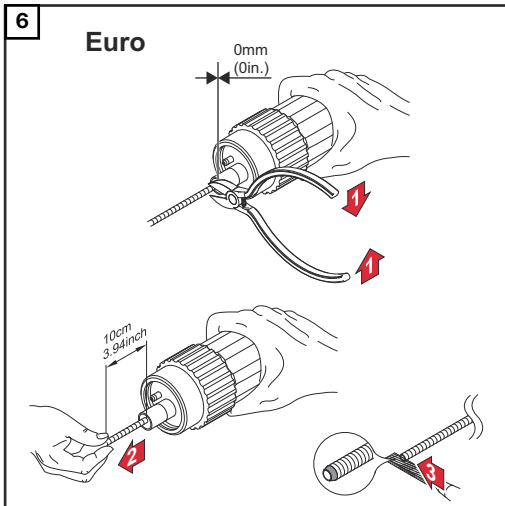

**Montaggio della
guaina guidafilo
in plastica (F, F+
+)**

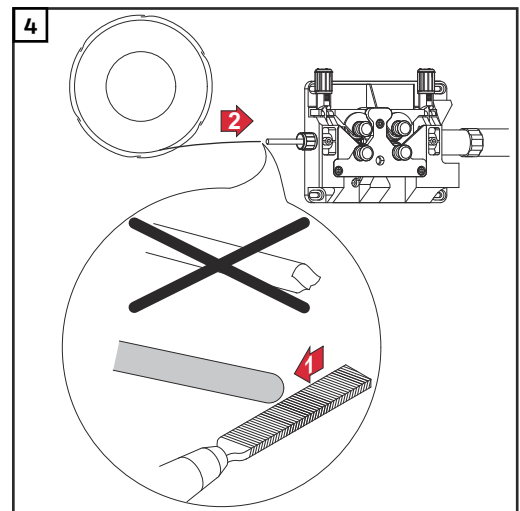
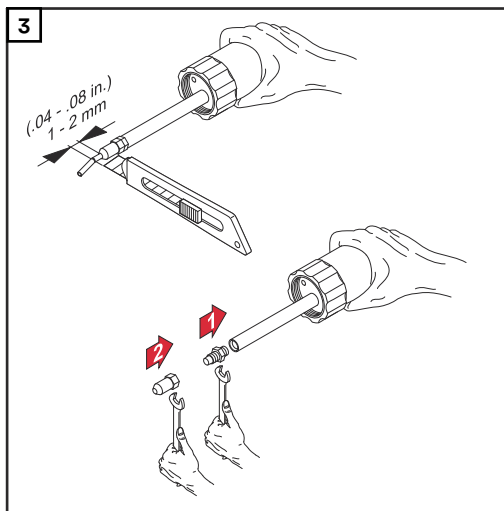
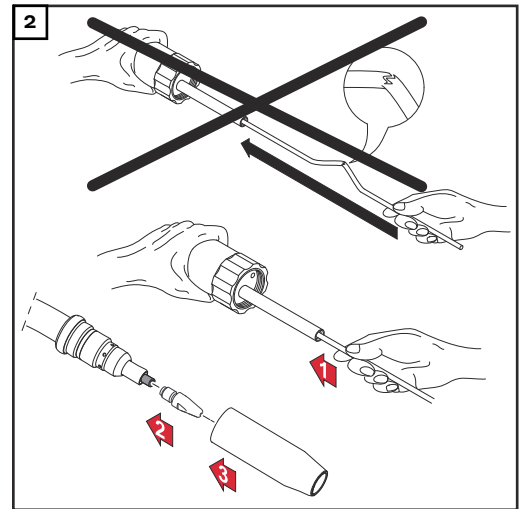
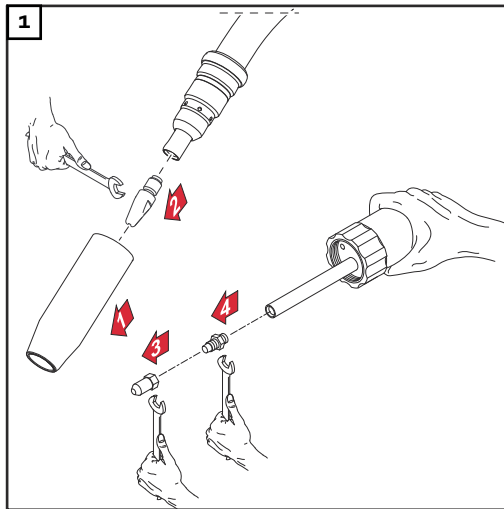

IT

Montaggio della guaina in plastica (attacco Fronius con ugello per guaina guidafile)

AVVERTENZA!

Prima di inserire l'elettrodo a filo, smussare l'estremità dell'elettrodo a filo.

Vale per le guaine in teflon, le guaine combinate e le guaine in grafite.

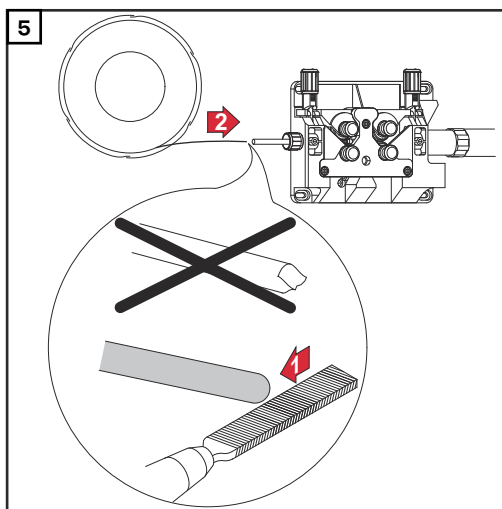
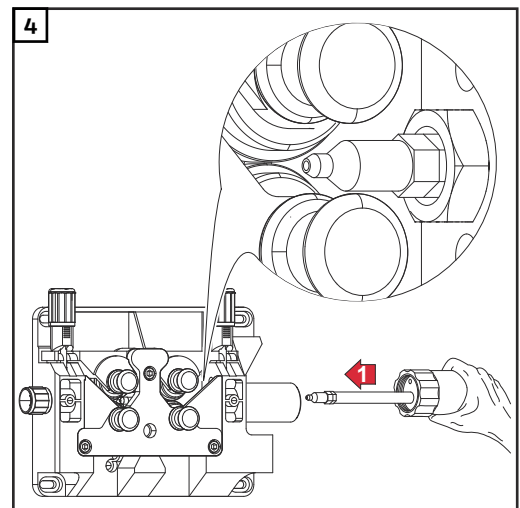
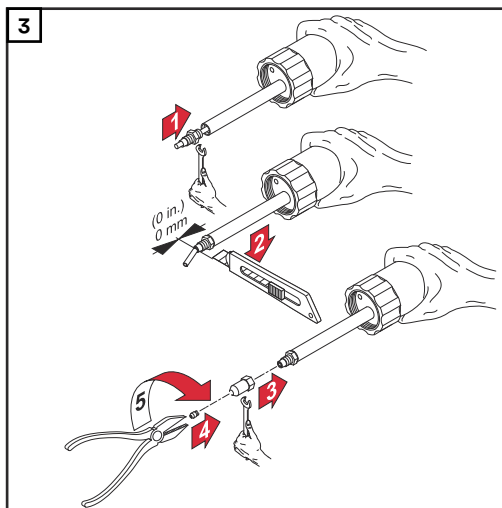
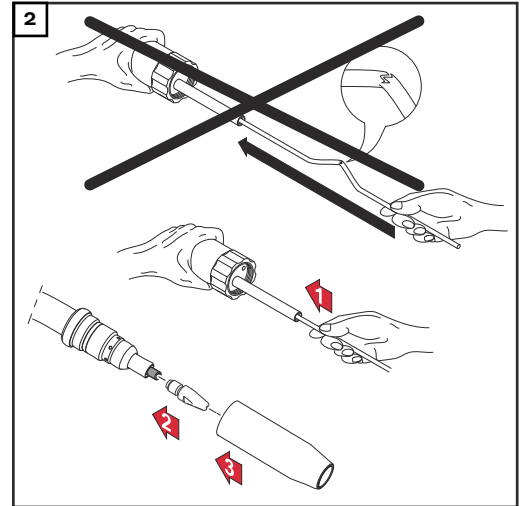
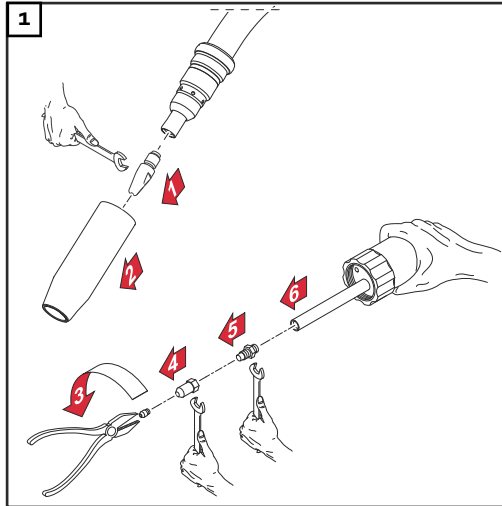

Montaggio della guaina guidafilo in plastica (Euro)

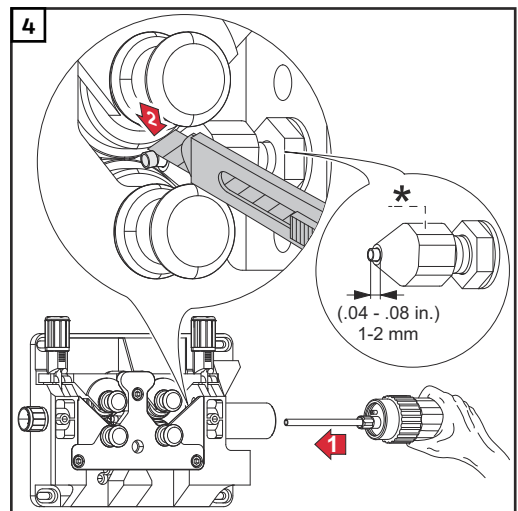
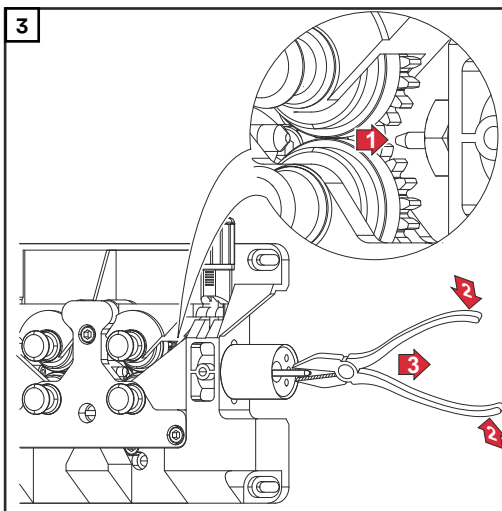
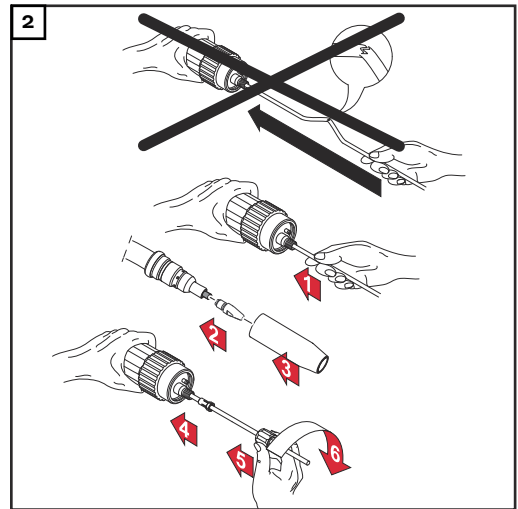
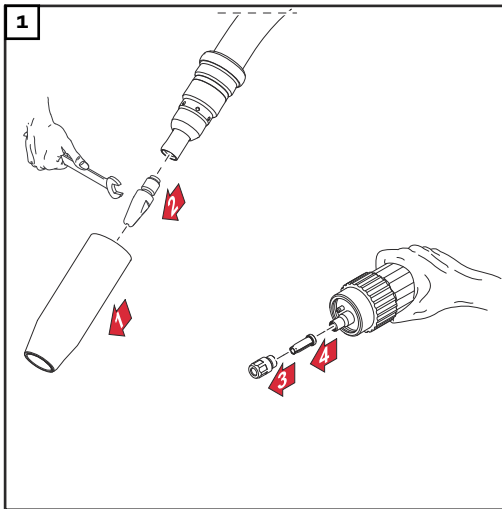

* Opzione ugello d'inserimento (42,0001,5421).

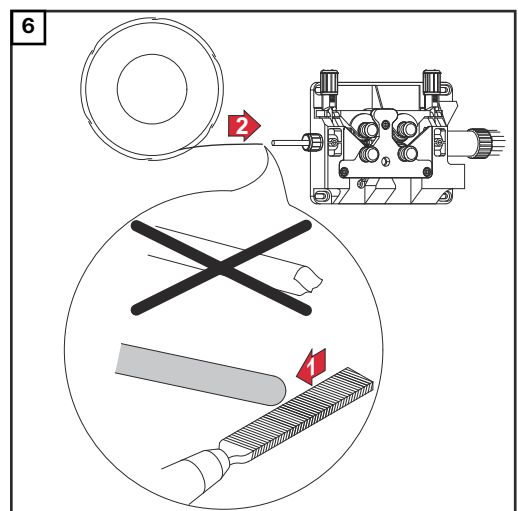
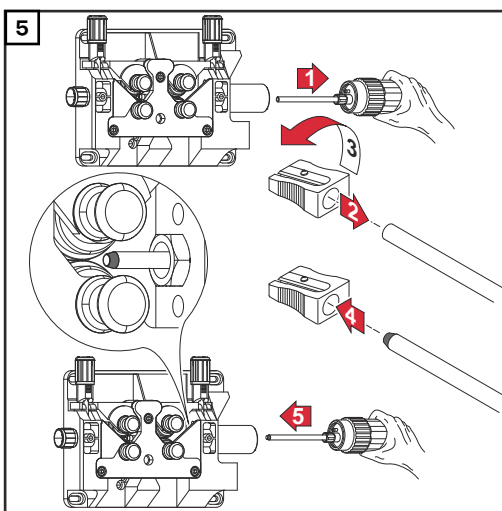

IT

Messa in funzione

Collegamento della torcia per saldatura

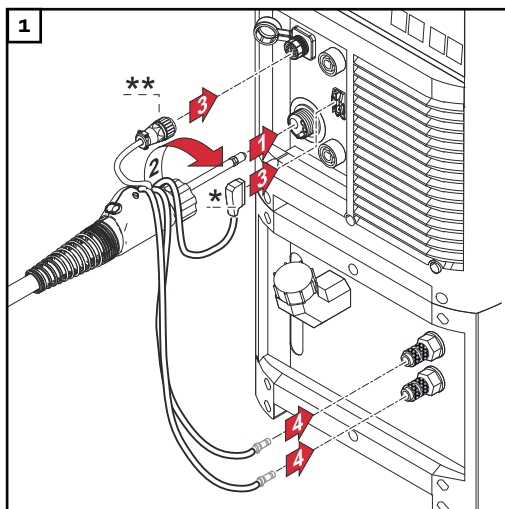

- * Connettore LocalNet (torcia per saldatura standard o Up/Down)
- ** Connettore JobMaster (torcia per saldatura JobMaster)

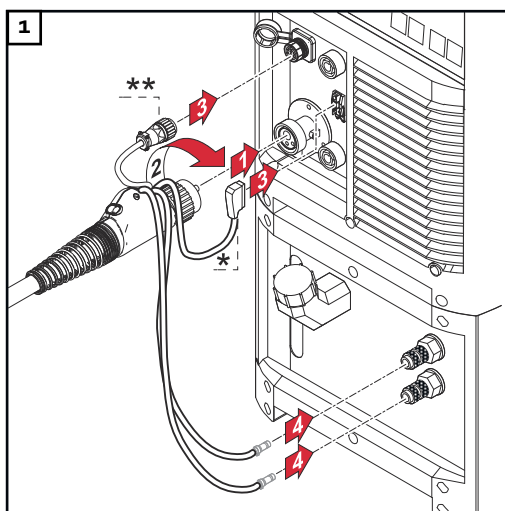

- * Connettore LocalNet (torcia per saldatura standard o Up/Down)
- ** Connettore JobMaster (torcia per saldatura JobMaster)

Collegamento dell'aspirazione

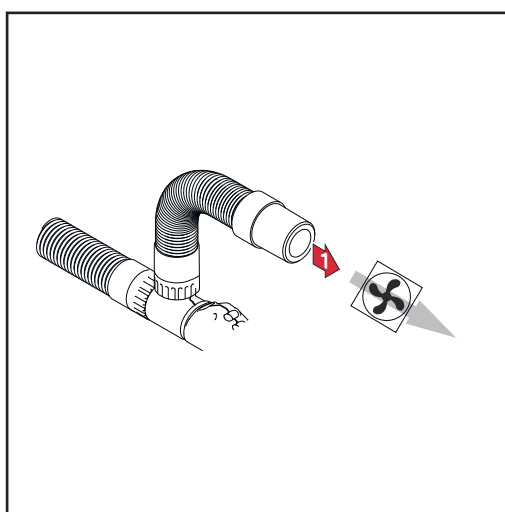

- 1 Collegare il tubo di aspirazione all'aspiratore secondo i valori indicativi degli aspiratori.

**Rotazione del
corpo torcia del-
la torcia per sal-
datura Multilock**

⚠ PRUDENZA!

Il refrigerante e il corpo della torcia surriscaldati possono causare ustioni.

- ▶ Prima di iniziare qualsiasi lavoro, lasciare raffreddare il refrigerante e il corpo torcia a temperatura ambiente (+25 °C, +77 °F).

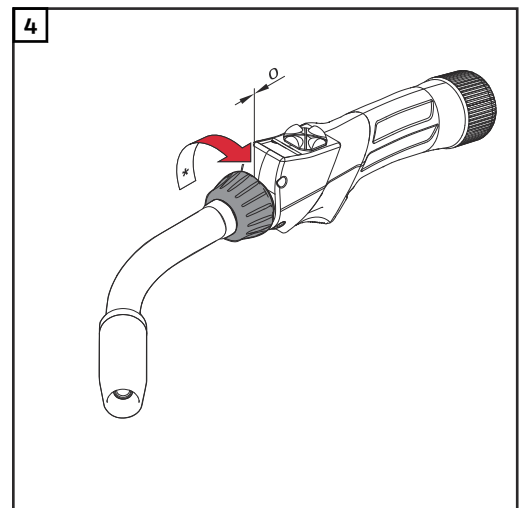
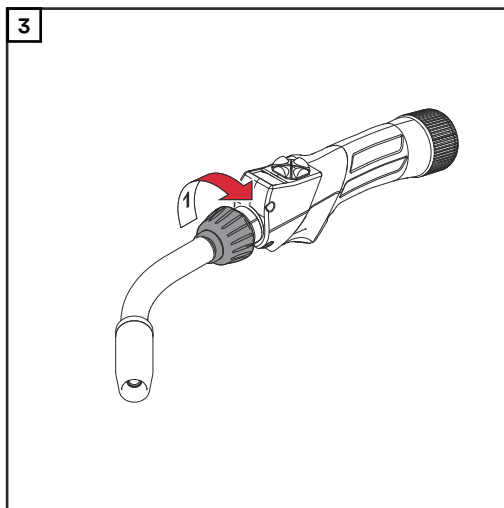
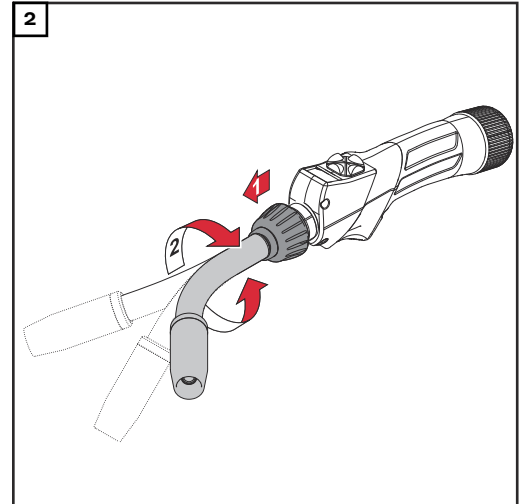
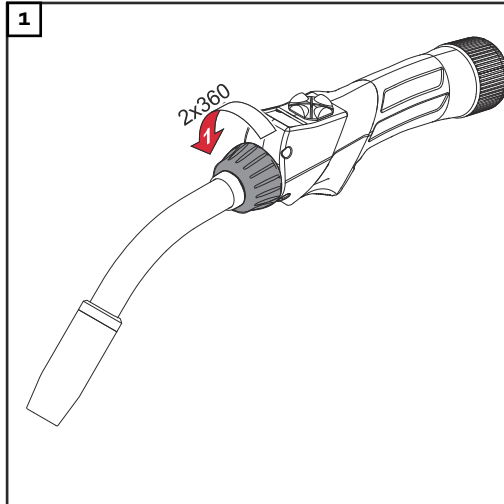

* Assicurarsi che il dado per raccordi sia serrato completamente.

IT

Sostituzione del corpo torcia della torcia per saldatura Multilock

⚠ PRUDENZA!

Il refrigerante e il corpo della torcia surriscaldati possono causare ustioni. può causare gravi ustioni.

- ▶ Prima di iniziare qualsiasi lavoro, lasciare raffreddare il refrigerante e il corpo torcia a temperatura ambiente (+25 °C, +77 °F).

AVVERTENZA!

Nel corpo della torcia sono sempre presenti residui di refrigerante.

Smontare il corpo della torcia solo con l'ugello del gas rivolto verso il basso.

AVVERTENZA!

Prima di montare un corpo della torcia, assicurarsi che il punto di collegamento del corpo della torcia e del pacchetto tubi flessibili sia integro e pulito.

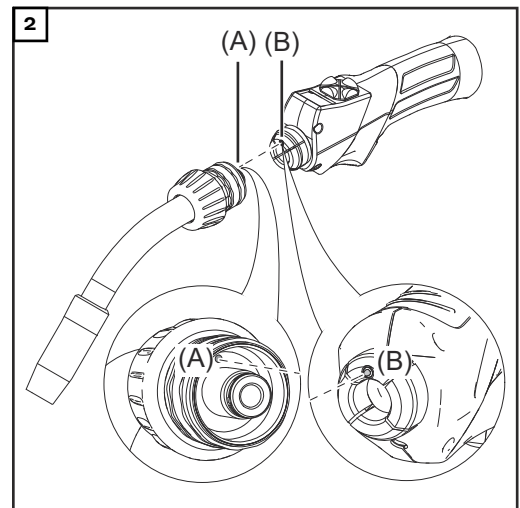
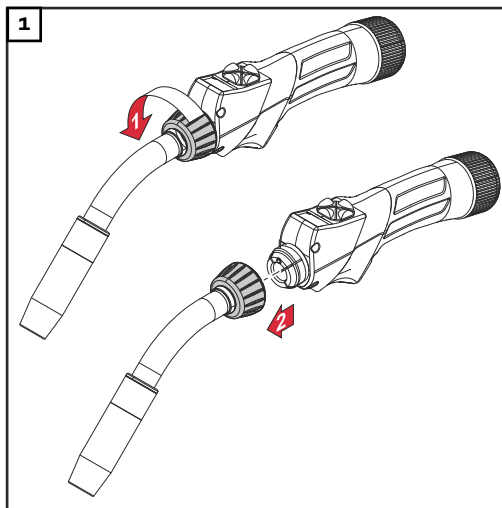

AVVERTENZA!

Quando la spina di registro (A) del pacchetto tubi flessibili si inserisce nel foro di riferimento (B) del corpo della torcia, il corpo torcia è posizionato a 0°.

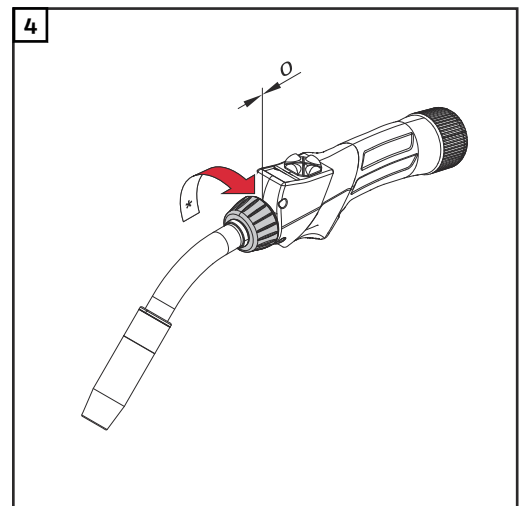
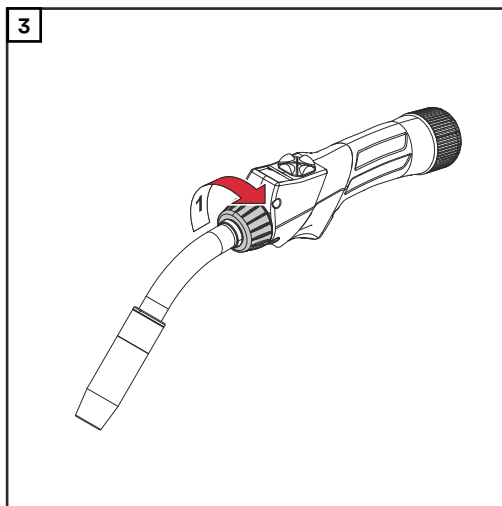

* Assicurarsi che il dado per raccordi sia serrato completamente.

**Supporto con
profilo sagomato
per torcia per
saldatura a mac-
china**

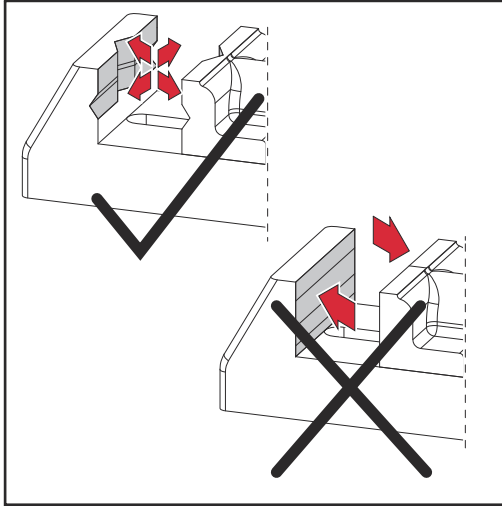

Bloccare la torcia per saldatura a macchina da preparare esclusivamente all'interno di un supporto con profilo sagomato adatto!

Cura e manutenzione

In generale

Una manutenzione regolare e preventiva della torcia per saldatura è fondamentale per garantirne il corretto funzionamento. La torcia per saldatura è esposta a temperature elevate e accumuli di impurità. Per questo motivo richiede una manutenzione più frequente rispetto ad altri componenti del sistema di saldatura.

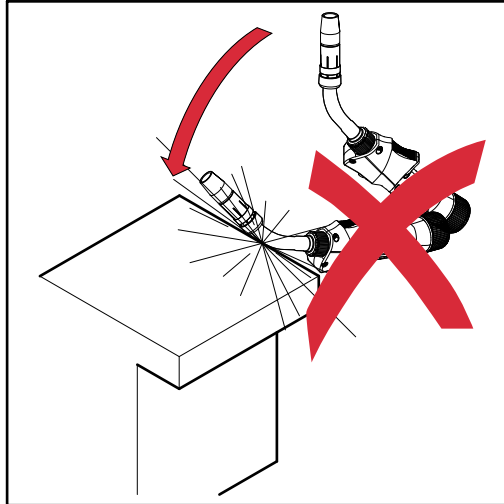

PRUDENZA!

L'uso improprio della torcia per saldatura

può causare gravi danni materiali.

- ▶ Non battere la torcia per saldatura su oggetti duri.
- ▶ Evitare di rigare e graffiare il tubo di contatto.
- ▶ Non piegare in nessun caso il corpo torcia.

Riconoscimento dei pezzi soggetti ad usura difettosi

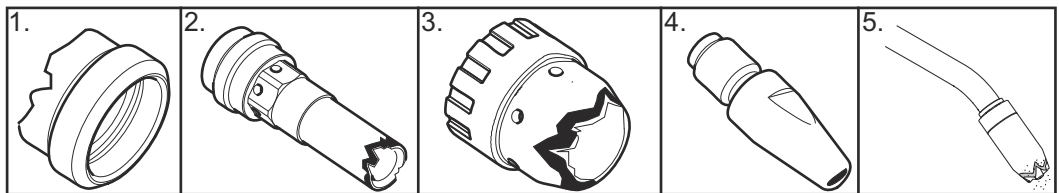

1. Elementi isolanti
 - spigoli esterni bruciati, intaccature.
2. supporti degli ugelli
 - spigoli esterni bruciati, intaccature
 - incollatura a causa degli spruzzi di saldatura.
3. Protezione antispruzzo
 - spigoli esterni bruciati, intaccature.
4. Tubi di contatto
 - fori di ingresso e di uscita del filo ovalizzati
 - incollatura a causa degli spruzzi di saldatura
 - punta del tubo di contatto bruciata.
5. Ugelli del gas
 - incollatura a causa degli spruzzi di saldatura
 - spigoli esterni bruciati
 - intaccature.

Manutenzione a ogni messa in funzione

- Controllare i pezzi soggetti a usura
- Sostituire i pezzi soggetti a usura difettosi.
- Asportare gli spruzzi di saldatura dall'ugello del gas.

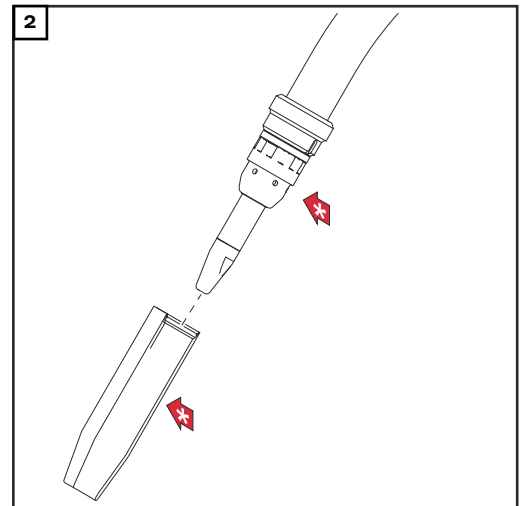
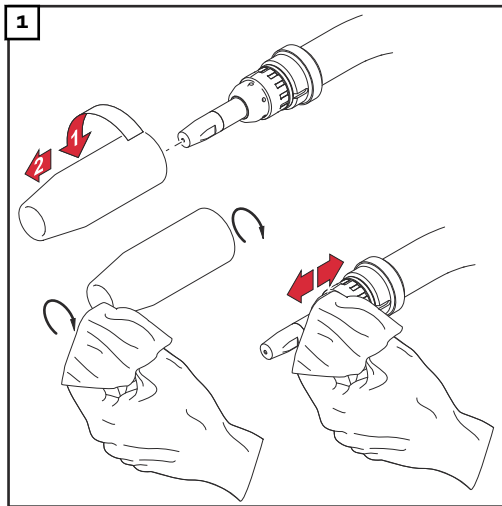

- * Controllare che ugello del gas, protezione antispruzzo e isolamenti non presentino danni e sostituire i componenti danneggiati.
- Inoltre, a ogni messa in funzione per le torce per saldatura raffreddate ad acqua:
 - assicurarsi che tutti gli attacchi del refrigerante siano a tenuta stagna
 - assicurarsi che il flusso di ritorno del refrigerante sia regolare.

Manutenzione ad ogni sostituzione della bobina filo/ bobina intrecciata

- Pulire il tubo di alimentazione filo con aria compressa ridotta.
- Consigliato: sostituire la guaina guidafile, pulire i pezzi soggetti a usura prima di installare di nuovo la guaina guidafile.

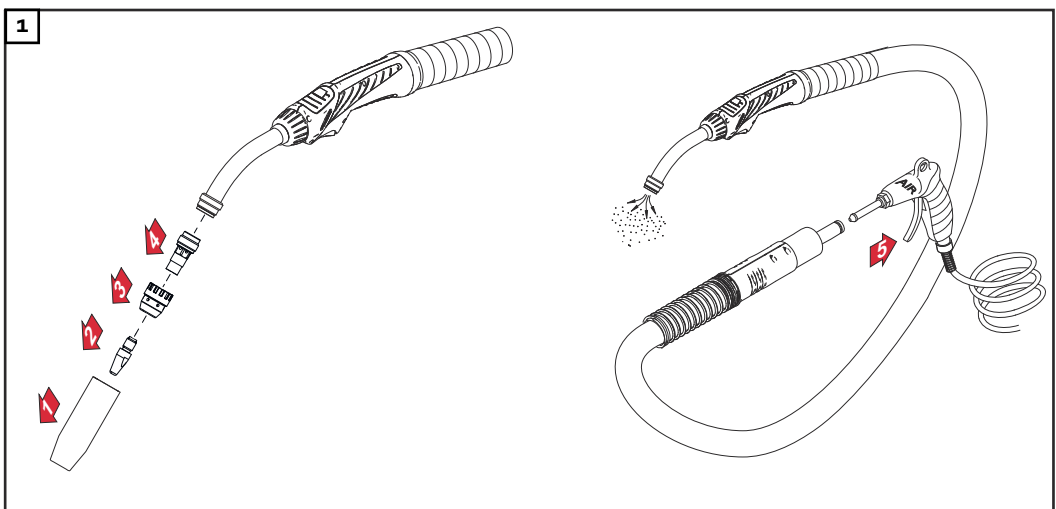

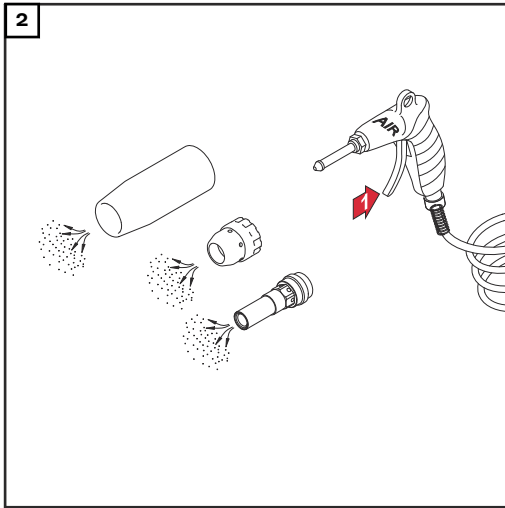

Diagnosi e risoluzione degli errori

Diagnosi e risoluzione degli errori

Corrente di saldatura assente

Interruttore di rete del generatore inserito, spie sul generatore accese, gas inerte presente.

Causa: collegamento a massa errato.

Risoluzione: eseguire il collegamento a massa in modo regolare.

Causa: cavo della corrente della torcia per saldatura interrotto.

Risoluzione: sostituire la torcia per saldatura.

Anche premendo il tasto della torcia, questa non funziona

Interruttore di rete del generatore inserito, spie sul generatore accese.

Causa: FSC ("Fronius System Connector", attacco centrale) non inserito completamente.

Risoluzione: inserire completamente l'FSC.

Causa: torcia per saldatura o cavo di comando della torcia difettosi.

Risoluzione: sostituire la torcia per saldatura.

Causa: pacchetto tubi flessibili di collegamento non regolarmente collegato o difettoso.

Risoluzione: collegare regolarmente il pacchetto tubi flessibili di collegamento;
sostituire il pacchetto tubi flessibili di collegamento difettoso.

Causa: generatore difettoso.

Risoluzione: contattare il servizio di assistenza.

Gas inerte assente

Tutte le altre funzioni sono disponibili.

Causa: bombola del gas vuota.

Risoluzione: sostituire la bombola del gas.

Causa: riduttore di pressione del gas difettoso.

Risoluzione: sostituire il riduttore di pressione del gas.

Causa: tubo del gas smontato, piegato o danneggiato.

Risoluzione: montare il tubo del gas, disporlo dritto. Sostituire il tubo del gas difettoso.

Causa: torcia per saldatura difettosa.

Risoluzione: sostituire la torcia per saldatura.

Causa: valvola magnetica del gas difettosa.

Risoluzione: contattare il servizio di assistenza (per far sostituire la valvola magnetica del gas).



Proprietà di saldatura scarse

Causa:	parametri di saldatura errati.
Risoluzione:	correggere le impostazioni.
Causa:	Cattivo collegamento a massa.
Risoluzione:	creare un buon contatto con il pezzo da lavorare.
Causa:	gas inerte assente o insufficiente.
Risoluzione:	controllare il riduttore di pressione del gas, il tubo del gas, la valvola magnetica del gas e l'attacco del gas inerte della torcia per saldatura. Per le torce per saldatura raffreddate a gas, controllare la guarnizione di tenuta del gas, utilizzare una guaina guidafile idonea.
Causa:	torcia per saldatura non ermetica.
Risoluzione:	sostituire la torcia per saldatura.
Causa:	tubo di contatto troppo grande o usurato.
Risoluzione:	sostituire il tubo di contatto.
Causa:	lega del filo o diametro del filo errati.
Risoluzione:	controllare la bobina filo/intrecciata inserita.
Causa:	lega del filo o diametro del filo errati.
Risoluzione:	verificare la saldabilità del materiale di base.
Causa:	gas inerte non adatto alla lega del filo.
Risoluzione:	utilizzare il gas inerte adatto.
Causa:	condizioni di saldatura sfavorevoli: impurità nel gas inerte (umidità, aria), protezione con gas carente (il bagno di fusione "cuoce", aria di trazione), impurità sul pezzo da lavorare (ruggine, vernice, grasso).
Risoluzione:	ottimizzare le condizioni di saldatura.
Causa:	fuoriuscita del gas inerte dal nipplo di serraggio.
Risoluzione:	utilizzare il nipplo di serraggio giusto.
Causa:	disco di tenuta del nipplo di serraggio difettoso, fuoriuscita del gas inerte dal nipplo di serraggio.
Risoluzione:	sostituire i nippoli di serraggio per garantire la tenuta di gas.
Causa:	spruzzi di saldatura nell'ugello del gas.
Risoluzione:	rimuovere gli spruzzi di saldatura.
Causa:	turbolenze causate da un'eccessiva quantità di gas inerte.
Risoluzione:	ridurre la quantità di gas inerte; si consiglia la seguente proporzione: quantità di gas inerte (l/min) = diametro del filo (mm) x 10 (ad es. 16 l/min per elettrodo a filo da 1,6 mm).
Causa:	distanza eccessiva tra la torcia per saldatura e il pezzo da lavorare.

Risoluzione:	ridurre la distanza tra la torcia per saldatura e il pezzo da lavorare (ca. 10-15 mm / 0.39-0.59 in.).
Causa:	angolo di incidenza della torcia per saldatura troppo ampio.
Risoluzione:	ridurre l'angolo di incidenza della torcia per saldatura.
Causa:	i componenti di avanzamento del filo non sono adatti al diametro dell'elettrodo a filo / al materiale dell'elettrodo a filo.
Risoluzione:	utilizzare i componenti di avanzamento filo corretti.

Cattiva alimentazione del filo

Causa:	a seconda del sistema, regolazione del freno nel carrello traina filo o nel generatore troppo rigida.
Risoluzione:	allentare la regolazione del freno.
Causa:	foro del tubo di contatto spostato.
Risoluzione:	sostituire il tubo di contatto.
Causa:	guaina guidafile o inserto guidafile difettosi.
Risoluzione:	controllare l'eventuale presenza di impurità, piegature, ecc. sulla guaina guidafile o sull'inserto guidafile; sostituire la guaina guidafile o l'inserto guidafile difettosi.
Causa:	rulli d'avanzamento non adatti all'elettrodo a filo utilizzato.
Risoluzione:	utilizzare rulli d'avanzamento adatti.
Causa:	pressione d'aderenza dei rulli d'avanzamento errata.
Risoluzione:	Ottimizzare la pressione d'aderenza.
Causa:	rulli d'avanzamento sporchi o danneggiati.
Risoluzione:	pulire o sostituire i rulli d'avanzamento.
Causa:	guaina guidafile spostata o piegata.
Risoluzione:	sostituire la guaina guidafile.
Causa:	guaina guidafile troppo corta dopo il taglio a misura.
Risoluzione:	sostituire la guaina guidafile e accorciare la guaina guidafile nuova alla lunghezza corretta.
Causa:	abrasione dell'elettrodo a filo causata da una pressione d'aderenza eccessiva sui rulli d'avanzamento.
Risoluzione:	ridurre la pressione d'aderenza sui rulli d'avanzamento.
Causa:	elettrodo a filo sporco o arrugginito.
Risoluzione:	utilizzare elettrodi a filo di qualità superiore e privi di impurità.
Causa:	per le guaine guidafile in acciaio: guaina guidafile non rivestita in uso.
Risoluzione:	utilizzare una guaina guidafile rivestita.
Causa:	area di entrata e di uscita del filo del nipplo di serraggio deformata (ovalizzata), fuoriuscita del gas inerte dal nipplo di serraggio.
Risoluzione:	sostituire i nippoli di serraggio per garantire la tenuta di gas.

L'ugello del gas si surriscalda

Causa: assenza di dissipazione del calore a causa dell'ugello del gas allentato.

Risoluzione: serrare completamente l'ugello del gas.

La torcia per saldatura si surriscalda

Causa: solo per le torce per saldatura Multilock: dado per raccordi del corpo torcia allentato.

Risoluzione: serrare il dado per raccordi.

Causa: la torcia per saldatura è stata utilizzata con una corrente di saldatura superiore a quella massima.

Risoluzione: ridurre la potenza di saldatura o utilizzare una torcia per saldatura con prestazioni più elevate.

Causa: torcia per saldatura sottodimensionata.

Risoluzione: rispettare il tempo di accensione e i limiti di carico.

Causa: solo per impianti raffreddati ad acqua: flusso del refrigerante insufficiente.

Risoluzione: controllare il livello, la portata e il grado di impurità del refrigerante, la disposizione del pacchetto tubi flessibili, ecc.

Causa: punta della torcia per saldatura troppo vicina all'arco voltaico.

Risoluzione: aumentare lo stick-out.

Breve durata del tubo di contatto

Causa:	rulli d'avanzamento errati.
Risoluzione:	utilizzare i rulli d'avanzamento corretti.
Causa:	abrasione dell'elettrodo a filo causata da una pressione d'aderenza eccessiva sui rulli d'avanzamento.
Risoluzione:	ridurre la pressione d'aderenza sui rulli d'avanzamento.
Causa:	elettrodo a filo sporco / arrugginito.
Risoluzione:	utilizzare elettrodi a filo di qualità superiore e privi di impurità.
Causa:	elettrodo a filo non isolato.
Risoluzione:	utilizzare un elettrodo a filo con isolamento adeguato.
Causa:	dimensioni del tubo di contatto errate.
Risoluzione:	dimensionare correttamente il tubo di contatto.
Causa:	tempo di accensione della torcia per saldatura eccessivamente lungo.
Risoluzione:	ridurre il tempo di accensione o utilizzare una torcia per saldatura a prestazioni più elevate.
Causa:	tubo di contatto surriscaldato. Assenza di dissipazione del calore a causa del tubo di contatto allentato.
Risoluzione:	stringere il tubo di contatto.

AVVERTENZA!

Nelle applicazioni CrNi è possibile che il tubo di contatto si usuri maggiormente per via della qualità della superficie dell'elettrodo a filo CrNi.

Anomalia di funzionamento del tasto della torcia

Causa:	collegamenti a spina tra torcia per saldatura e generatore difettosi.
Risoluzione:	eseguire i collegamenti a spina in modo regolare / inviare il generatore o la torcia per saldatura all'assistenza.
Causa:	presenza di impurità tra il tasto della torcia e il suo corpo esterno.
Risoluzione:	eliminare le impurità.
Causa:	cavo di comando difettoso.
Risoluzione:	contattare il servizio di assistenza.



Porosità del giunto saldato

Causa:	accumulo di spruzzi nell'ugello del gas, da cui deriva una protezione antigas insufficiente del giunto saldato.
Risoluzione:	rimuovere gli spruzzi di saldatura.
Causa:	tubo del gas forato o collegamento impreciso del tubo del gas.
Risoluzione:	sostituire il tubo del gas.
Causa:	guarnizione circolare sull'attacco centrale danneggiata o difettosa.
Risoluzione:	sostituire la guarnizione circolare.
Causa:	umidità/condensa nel tubo del gas.
Risoluzione:	asciugare il tubo del gas.
Causa:	flusso del gas eccessivo o insufficiente.
Risoluzione:	correggere il flusso del gas.
Causa:	portata del gas insufficiente all'inizio o al termine della saldatura.
Risoluzione:	aumentare la preapertura del gas e il ritardo di chiusura del gas.
Causa:	elettrodo a filo arrugginito o di scarsa qualità.
Risoluzione:	utilizzare elettrodi a filo di qualità superiore e privi di impurità.
Causa:	per le torce per saldatura raffreddate a gas: fuoriuscita del gas con guaine guidafile non isolate.
Risoluzione:	con le torce per saldatura raffreddate a gas, utilizzare solo guaine guidafile isolate.
Causa:	apporto eccessivo di agente di distacco.
Risoluzione:	rimuovere l'agente di distacco in eccesso/apportare meno agente di distacco.
Causa:	aspirazione eccessiva.
Risoluzione:	ridurre l'aspirazione.

Aspirazione insufficiente

Causa:	tubo di aspirazione bucato.
Risoluzione:	ripristinare il tubo di aspirazione.
Causa:	filtro di aspirazione spostato.
Risoluzione:	ripristinare il filtro di aspirazione.
Causa:	vie d'aria ostruite in altro modo.
Risoluzione:	eliminare le ostruzioni.
Causa:	potenza di aspirazione dell'aspiratore insufficiente; configurazione errata di OPT/i FumeEx.
Risoluzione:	utilizzare l'aspiratore con una potenza di aspirazione più elevata; aumentare la potenza di aspirazione.

Dati tecnici

In generale

Misurazione tensione (V-Peak):

- per torce per saldatura guidate manualmente: 113 V
- per torce per saldatura guidate a macchina: 141 V



Dati tecnici tasto della torcia:

- $U_{max} = 5 V$
- $I_{max} = 10 mA$

Il funzionamento del tasto della torcia è consentito esclusivamente nell'ambito dei dati tecnici.

Questo prodotto è conforme ai requisiti della norma IEC 60974-7 / 10 Cl. A.

Torcia per saldatura raffreddata a gas - MTG 250d-500d

	MTG 250d	MTG 320d	MTG 400d	MTG 500d
I (A) 10 min/40 °C CO ²	40% TA* 250 60% TA* 200 100% TA* 170	40% TA* 320 60% TA* 260 100% TA* 210	40% TA* 400 60% TA* 320 100% TA* 260	40% TA* 500 60% TA* *400 100% TA* 320
I (A) 10 min/40 °C M21	40% TA* 200 60% TA* 160 100% TA* 120	40% TA* 260 60% TA* 210 100% TA* 160	40% TA* 320 60% TA* 260 100% TA* 210	40% TA* 400 60% TA* 320 100% TA* 260
 [mm (in.)]	0,8-1,2 (.032-.047)	0,8-1,6 (.032-.063)	1,0-1,6 (.039-.063)	1,0-1,6 (.039-.063)
 [m (ft.)]	3,5 / 4,5 (12 / 15)	3,5 / 4,5 (12 / 15)	3,5 / 4,5 (12 / 15)	3,5 / 4,5 (12 / 15)

* TA = tempo di accensione

Corpo della torcia raffreddata a gas - MTB 250i, 320i, 330i, 400i, 550i G ML

	MTB 250i G ML	MTB 320i G ML	MTB 330i G ML
I (A) 10 min/40 °C M21+C1 (EN 439)	40% TA* 250 60% TA* 200 100% TA* 170	40% TA* 320 60% TA* 260 100% TA* 210	40% TA* 330 60% TA* 270 100% TA* 220
 [mm (in.)]	0,8-1,2 (.032-.047)	0,8-1,6 (.032-.063)	0,8-1,6 (.032-.063)



* TA = tempo di accensione

	MTB 400i G ML	MTB 550i G ML
I (A) 10 min/40 °C C1 (EN 439)	-	30% TA* 550

	MTB 400i G ML	MTB 550i G ML
I (A) 10 min/40 °C M21 (EN 439)	-	30% TA* 520
I (A) 10 min/40 °C M21+C1 (EN 439)	40% TA* 400 60% TA* 320 100% TA* 260	- 60% TA* 420 100% TA* 360
 [mm (in.)]	0,8-1,6 (.032-.063)	0,8-1,6 (.032-.063)



* TA = tempo di accensione

Pacchetto tubi flessibili raffreddato a gas - MHP 400d G ML

	MHP 400d G ML
I (A) 10 min/40 °C CO ²	40% TA* 400 60% TA* 320 100% TA* 260
I (A) 10 min/40 °C M21	40% TA* 320 60% TA* 260 100% TA* 210
 [mm (in.)]	0,8-1,6 (.032-.063)
 [m (ft.)]	3,35/4,35 (11/14)

* TA = tempo di accensione







Pacchetto tubi flessibili raffreddato a gas - MHP 500d G ML M

	MHP 500d G ML M
I (A) 10 min/40 °C CO ²	40% TA* 500 60% TA* 400 100% TA* 320
I (A) 10 min/40 °C M21	40% TA* 400 60% TA* 320 100% TA* 260
 [mm (in.)]	0,8-1,6 (.032-.063)
 [m (ft.)]	1,35/2,35/3,35 (4.4/7.7/14)

* TA = tempo di accensione

Torcia per saldatura raffreddata ad acqua - MTW 250d-700d



	MTW 250d	MTW 400d	MTW 500d	MTW 700d
I (A) 10 min/40 °C CO ²	100% TA* 250	100% TA* 400	100% TA* 500	100% TA* 700
I (A) 10 min/40 °C M21	100% TA* 200	100% TA* 320	100% TA* 400	100% TA* 560

	MTW 250d	MTW 400d	MTW 500d	MTW 700d
 [mm (in.)]	0,8-1,2 (.032-.047)	0,8-1,6 (.032-.063)	0,8-1,6 (.032-.063)	0,8-1,6 (.032-.063)
Q _{min}  [l/min (gal./min)]	1 (.26)	1 (.26)	1 (.26)	1 (.26)
P _{min}  [W]**	500 (3,5 m) 600 (4,5 m)	800 (3,5 m) 950 (4,5 m)	1400 (3,5 m) 1700 (4,5 m)	1800 (3,5 m) 2200 (4,5 m)
P _{min}  [bar (psi.)]	3 (43)	3 (43)	3 (43)	3 (43)
P _{max}  [bar (psi.)]	5 (72)	5 (72)	5 (72)	5 (72)
 [m (ft.)]	3,5 / 4,5 (12 / 15)	3,5 / 4,5 (12 / 15)	3,5 / 4,5 (12 / 15)	3,5 / 4,5 (12 / 15)



* TA = tempo di accensione

** Potenza di raffreddamento minima secondo la norma IEC 60974-2

Corpo della torcia raffreddato ad acqua - MTB 250i, 330i, 400i, 500i, 700i W ML

	MTB 250i W ML	MTB 330i W ML	MTB 400i W ML	MTB 500i W ML
I (A) 10 min/40° C M21+C1 (EN 439)	100% TA* 250	100% TA* 330	100% TA* 400	100% TA* 500
 [mm (in.)]	0,8-1,2 (.032-.047)	0,8-1,6 (.032-.063)	0,8-1,6 (.032-.063)	1,0-1,6 (.039-.063)
Q _{min}  [l/min (gal./min)]	1 (.26)	1 (.26)	1 (.26)	1 (.26)

* TA = tempo di accensione







	MTB 700i W ML
I (A) 10 min/40° C M21+C1 (EN 439)	100% TA* 700
 [mm (in.)]	1,0-1,6 (.039-.063)
Q _{min}  [l/min (gal./min)]	1 (.26)

* TA = tempo di accensione

Pacchetto tubi flessibili raffreddato ad acqua - MHP 500d, 700d W ML

	MHP 500d W ML	MHP 700d W ML
I (A) 10 min/40° C CO ²	100% TA* 500	100% TA* 700
I (A) 10 min/40° C M21	100% TA* 400	100% TA* 560









		MHP 500d W ML	MHP 700d W ML
	[mm (in.)]	0,8-1,6 (.032-.063)	0,8-1,6 (.032-.063)
	[m (ft.)]	3,35/4,35 (11/14)	3,35/4,35 (11/14)
P _{min} 	[W]**	1400 / 1700	1800 / 2200
Q _{min} 	[l/min (gal./min.)]	1 (.26)	1 (.26)
P _{min} 	[bar (psi.)]	3 (43)	3 (43)
P _{max} 	[bar (psi.)]	5 (72)	5 (72)

* TA = tempo di accensione

** Potenza di raffreddamento minima secondo la norma IEC 60974-2



Pacchetto tubi flessibili raffreddato ad acqua - MHP 700d W ML M

		MHP 700d W ML M
I (A) 10 min/40° C CO ²		100% TA* 700
I (A) 10 min/40° C M21		100% TA* 560
	[mm (in.)]	0,8-1,6 (.032-.063)
	[m (ft.)]	1,35/2,35/3,35 (4.4/7.7/14)
P _{min} 	[W]**	1100 / 1450 / 1800
Q _{min} 	[l/min (gal./min.)]	1 (.26)
P _{min} 	[bar (psi.)]	3 (43)
P _{max} 	[bar (psi.)]	5 (72)

* TA = tempo di accensione

** Potenza di raffreddamento minima secondo la norma IEC 60974-2



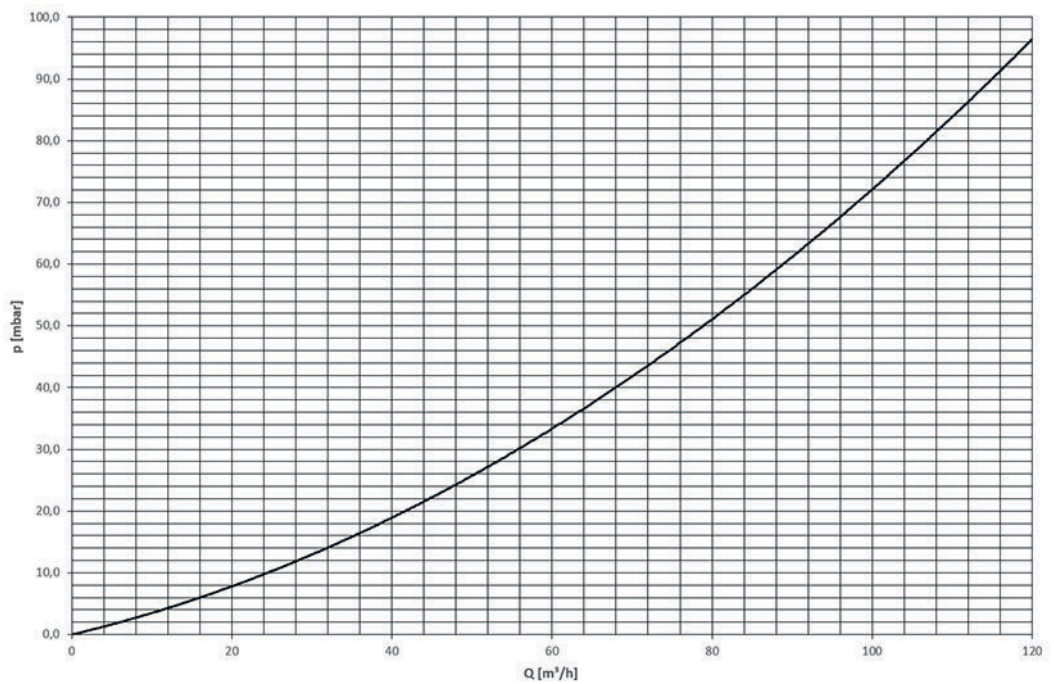

MTG 400d K4

		MTG 400d K4
I (A) 10 min/40 °C CO ₂ /mixed		40% TA* 400 60% TA* 320 100% TA* 260
 [mm (in.)]		0,8-1,6 (.032-.063)
 [m (ft.)]		4,5 (15)

* TA = tempo di accensione

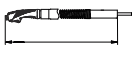
Curva caratteristica di aspirazione MTG 400d K4

MTW 500d K4

		MTW 500d K4
I (A) 10 min/40 °C CO ₂ /mixed		100 % TA* 500
 [mm (in.)]		0,8-1,6 (.032-.063)
 [m (ft.)]		4,5 (15)
P _{max}  [W]**		1700
Q _{min}  [l/min (gal./min)]		1 (26)
P _{min}  [bar (psi.)]		3 (43)
P _{max}  [bar (psi.)]		5 (72)

* TA = tempo di accensione.

** Potenza circuito refrigerante minima secondo la norma IEC 60974-2.

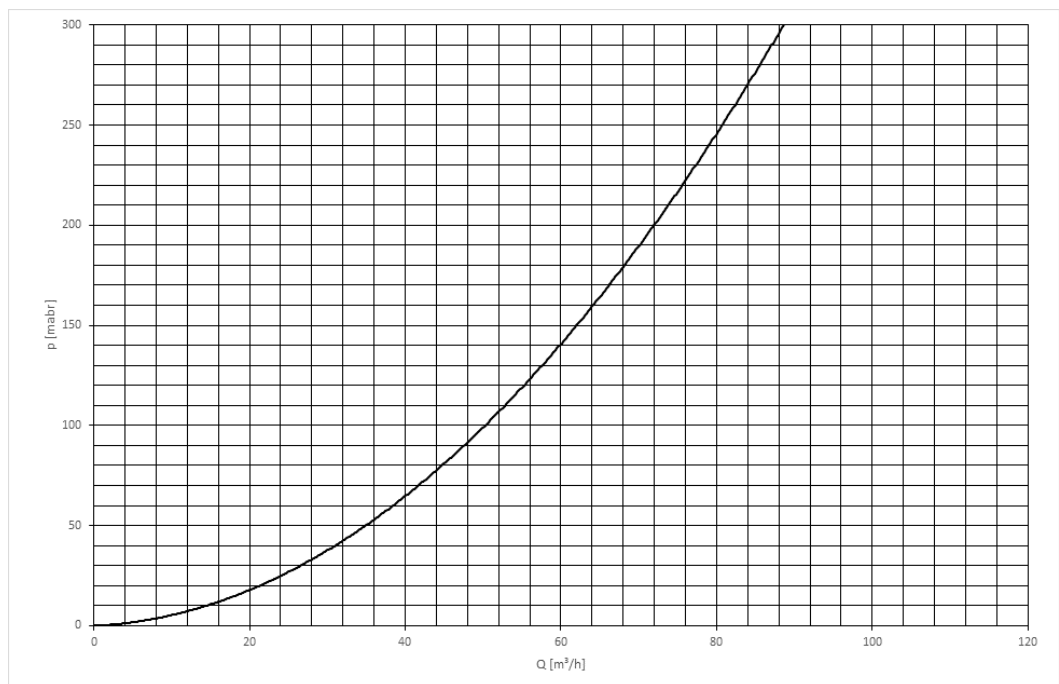
Curva caratteristica di aspirazione MTW 500d K4

Índice

Segurança.....	174
Utilização prevista.....	174
Segurança.....	174
Perigo devido à fumaça de soldagem.....	175
MTG d, MTW d, MHP d - Geral.....	176
Função up/down.....	176
Função JobMaster.....	176
MTG 400d K4, MTW 500d K4 - Geral.....	178
Informações gerais.....	178
Valor de referência para o aparelho de sucção.....	178
Regulador do fluxo de ar.....	178
Função up/down (para cima/para baixo).....	179
Montar as peças de desgaste no corpo da tocha de solda.....	180
MTG d, MTW d - Montar as peças de desgaste no corpo da tocha de solda.....	180
MTG 400d K4, MTW 500d K4 - montar as peças de desgaste.....	180
Montar o corpo da tocha de solda ML no jogo de mangueira MHP.....	182
Montar tocha de solda Multilock.....	182
Instalar os fios de revestimento interior.....	183
Verificação do bocal de fixação.....	183
Instalar o fio de revestimento interior de aço.....	183
Instalar o fio de revestimento interior de plástico (F, F++).....	185
Montar o revestimento de plástico (conexão-Fronius com bocal de guia-arame).....	186
Instalar o fio de revestimento interior de plástico (Euro).....	187
Comissionamento.....	188
Conectar a tocha de solda.....	188
Ligar a sucção.....	188
Torcer o corpo da tocha de solda Multilock.....	189
Substituir o corpo da tocha de solda Multilock.....	190
Suporte de prisma para tocha de máquinas.....	191
Conservação e manutenção.....	192
Informações gerais.....	192
Reconhecimento de peças de desgaste defeituosas.....	192
Manutenção em todo comissionamento.....	192
Manutenção a cada substituição das bobinas de arame/de cesta.....	193
Diagnóstico de erro, eliminação de erro.....	195
Diagnóstico de erro, eliminação de erro.....	195
Dados técnicos.....	201
Geral.....	201
Tocha de solda refrigerado a gás - MTG 250d - 500d.....	201
Corpo da tocha de solda refrigerada a gás - tubo curvado MIG/MAG 250i, 320i, 330i, 400i, 550i G ML.....	201
Jogo de mangueira refrigerado a gás - MHP 400d G ML.....	202
Jogo de mangueira refrigerado a gás - MHP 500d G ML M.....	202
Tocha de solda refrigerado a água - MTW 250d - 700d.....	203
Corpo da tocha de solda refrigerada a água - tubo curvado MIG/MAG 250i, 330i, 400i, 500i, 700i W ML.....	203
Jogo de mangueira refrigerado a água - MHP 500d, 700d W ML.....	204
Jogo de mangueira refrigerado a água - MHP 700d W ML M.....	204
MTG 400d K4.....	205
Curva sinérgica de sucção MTG 400d K4.....	205
MTW 500d K4.....	206
Curva sinérgica de sucção MTW 500d K4.....	206

Segurança

Utilização prevista

A tocha manual MIG/MAG é destinada exclusivamente para soldagem MIG/MAG em aplicações manuais.

Qualquer outra utilização será considerada indevida. O fabricante não assume a responsabilidade por quaisquer danos decorrentes.

Também fazem parte da utilização prevista

- a consideração de todos os avisos do manual de instruções
 - o cumprimento dos trabalhos de inspeção e manutenção
-

Segurança

PERIGO!

Perigo devido a manuseio e trabalhos realizados incorretamente.

Podem ocorrer ferimentos e danos materiais graves.

- ▶ Todos os trabalhos e funções descritos nesse documento somente devem ser realizados por técnicos especializados e treinados.
 - ▶ Ler e compreender completamente este documento.
 - ▶ Todas as diretrizes de segurança e as documentações do usuário desse equipamento e de todos os componentes do sistema devem ser lidas e entendidas.
-

PERIGO!

Perigo devido à corrente elétrica.

Podem ocorrer ferimentos e danos materiais graves.

- ▶ Antes de começar os trabalhos, todos os equipamentos e componentes envolvidos devem ser desligados e desconectados da rede de energia.
 - ▶ Todos os equipamentos e componentes listados devem ser protegidos contra religamento.
-

PERIGO!

Perigo devido à corrente elétrica resultante de componentes do sistema danificados e operação incorreta.

Podem ocorrer ferimentos e danos materiais graves.

- ▶ Todos os cabos, tubulações e jogos de mangueira precisam estar sempre bem conectados, intactos e corretamente isolados.
 - ▶ Somente devem ser usados cabos, tubulações e jogos de mangueira dimensionados corretamente.
-

PERIGO!

Risco de escorregamento devido ao vazamento de refrigerador.

Podem ocorrer ferimentos e danos materiais graves.

- ▶ Sempre fechar as mangueiras do refrigerador da tocha de solda refrigerada a água com o fecho de plástico montado, quando elas forem desconectadas do dispositivo do refrigerador ou de outros componentes do sistema.
-

 **PERIGO!**

Perigo devido a componentes do sistema e/ou meio operacional quentes.

Podem ocorrer queimaduras graves.

- ▶ Antes de começar os trabalhos, todos os componentes do sistema e/ou outros meios operacionais quentes devem ser resfriados até +25 °C/+77 °F (por exemplo, refrigerador, componentes do sistema resfriados a água, motor de acionamento de velocidade do arame, etc.).
- ▶ Quando não for possível resfriar, usar equipamento de proteção adequado (por exemplo, luvas de proteção resistentes a calor, óculos de proteção, etc.).

 **PERIGO!**

Perigo de contato com a fumaça de soldagem.

Pode resultar em graves danos pessoais.

- ▶ Sempre extrair fumaça de soldagem.
- ▶ Providenciar uma alimentação suficiente de ar fresco. Se certificar que, uma taxa de ventilação de pelo menos 20 m³ (169070,1 US gi) por hora seja fornecida a todo momento.
- ▶ Em caso de dúvidas, um técnico de segurança deve determinar a quantidade de poluição no posto de trabalho.

 **CUIDADO!**

Perigo devido à operação sem refrigerador.

Podem ocorrer danos materiais.

- ▶ Nunca operar equipamentos refrigerados a água sem refrigerador.
- ▶ Durante a soldagem, garantir que o fluxo do líquido para o refrigerador seja adequado ao usar dispositivos do refrigerador da Fronius, se for o caso, é possível ver um retorno do refrigerador apropriado no recipiente de refrigeração do dispositivo do refrigerador.
- ▶ O fabricante não se responsabiliza por danos causados pela não observância dos pontos listados acima. Todas as reclamações de garantia serão rejeitadas.

Perigo devido à fumaça de soldagem

 **PERIGO!**

Perigo devido à fumaça gerada durante a soldagem, que contém gases e vapores prejudiciais à saúde.

Graves danos à saúde podem ser provocados.

- ▶ Não é permitida a operação de soldagem sem um dispositivo de sucção ligado.
- ▶ Em algumas circunstâncias, apenas o uso da tocha de extração de fumos pode não ser suficiente. Nesses casos, um aparelho de sucção adicional deve ser instalado para a redução da poluição no posto de trabalho.
- ▶ Em caso de dúvidas, um técnico de segurança deve determinar a quantidade de poluição no posto de trabalho.

MTG d, MTW d, MHP d - Geral

Função up/down

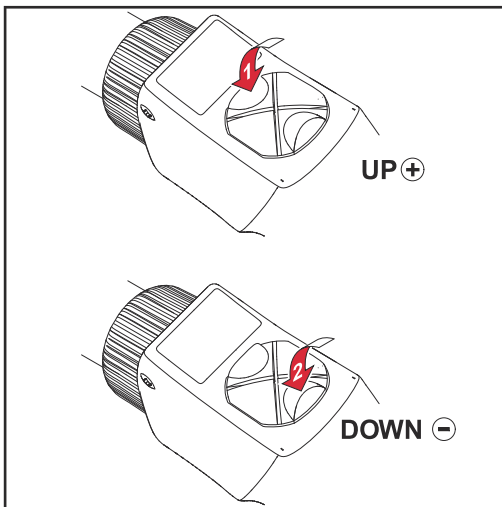

- Na fonte de solda, seleccionar um dos seguintes parâmetros:
 - Velocidade do arame
 - Numero do Job
- Configurar o parâmetro com a função up/down

IMPORTANTE! No modo de operação „Padrão sinérgico de solda MIG / MAG“, parâmetros adicionais podem ser configurados.

Função JobMaster

IMPORTANTE! No JobMaster, podem aparecer mensagens codificadas. Elas correspondem, ao mesmo tempo, ao código do serviço exibido no painel de comando (veja o manual de instruções da fonte de solda, capítulo „Diagnóstico e correção de erros“).

Synchro Puls (opção) - nenhum símbolo aparece no JobMaster (veja o manual de instruções da fonte de solda, capítulo „Soldagem MIG/MAG“).

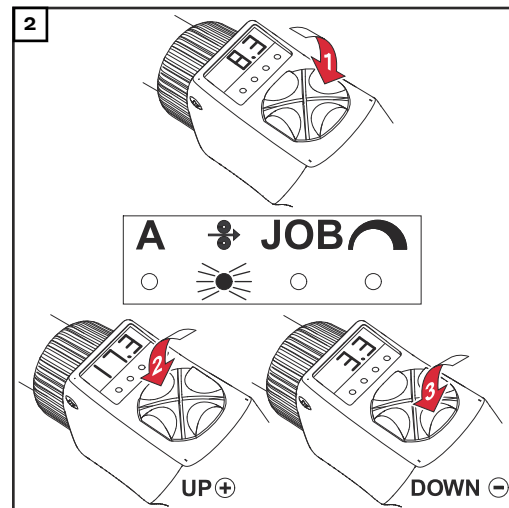
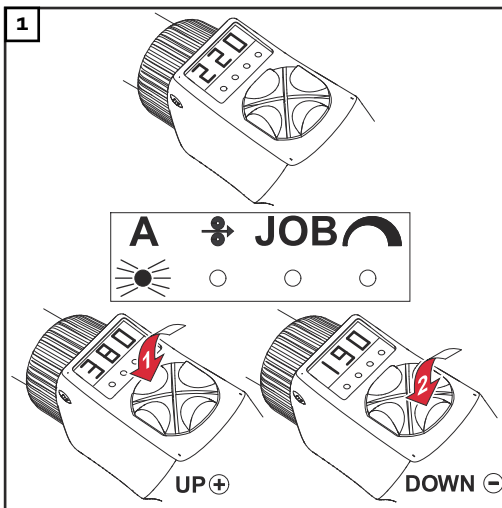

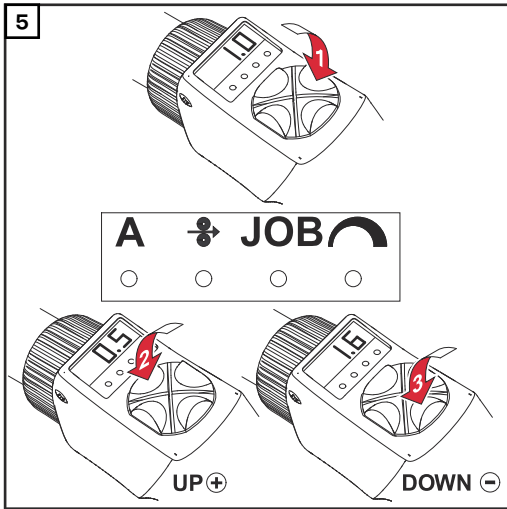
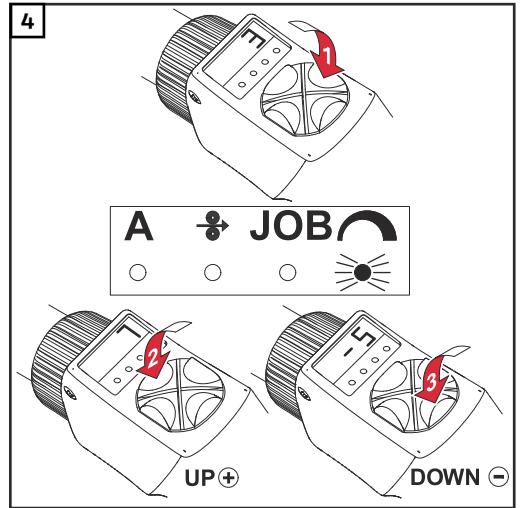
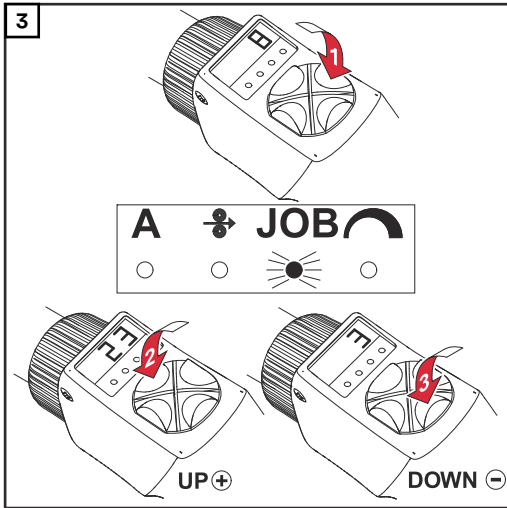

MTG 400d K4, MTW 500d K4 - Geral

Informações gerais

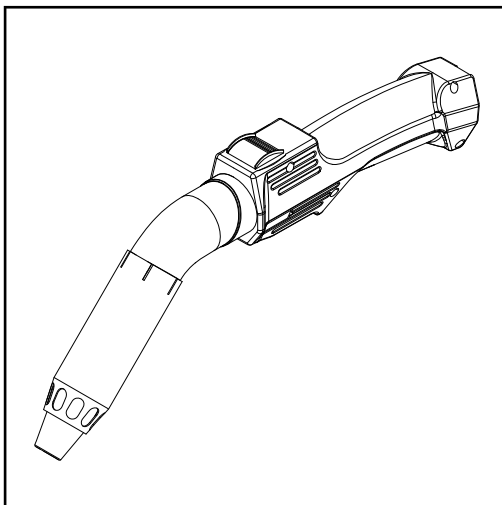

As tochas de extração de fumos MTG 400d K4 e MTW 500d K4 detectam a fumaça de soldagem prejudicial à saúde produzida durante a soldagem diretamente no ponto de origem. A fumaça de soldagem é sugada antes de atingir a área de respiração do soldador.

O valor da concentração máxima no posto de trabalho (MAK) deve ser menor ou igual aos valores legais permitidos.

Valor de referência para o aparelho de sucção

A tocha de extração de fumos deve estar de acordo com as seguintes especificações:

Eficiência de sucção

cerca de 100 m³/h

Valor da pressão negativa

entre 0,05 e 0,2 bar
(entre 5000 e 20000 Pa)

Regulador do fluxo de ar

Com o regulador do fluxo de ar, a quantidade de fumaça de soldagem extraída durante o processo de soldagem pode ser ajustada, de forma contínua, entre 10 e 100%.

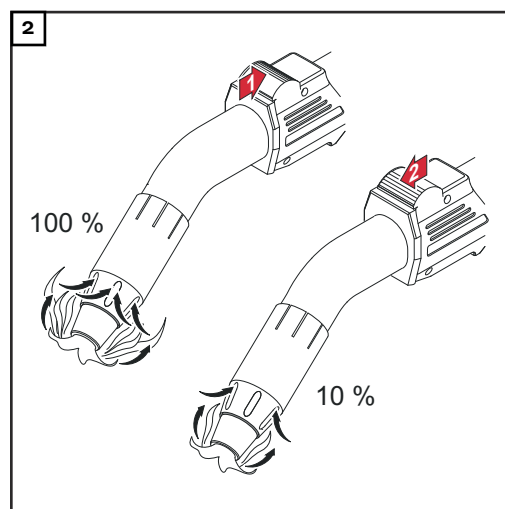
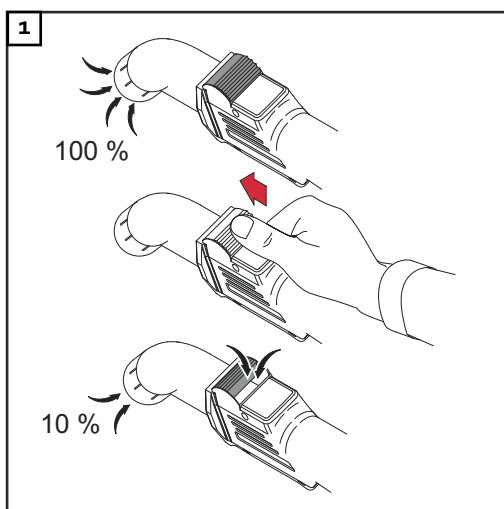

IMPORTANTE! O regulador da quantidade de fumaça de soldagem sugada é obrigatório quando gás de proteção é sugado juntamente com a fumaça de soldagem (por exemplo, soldagem em posição angular).

**Função up/down
(para cima/para
baixo)**

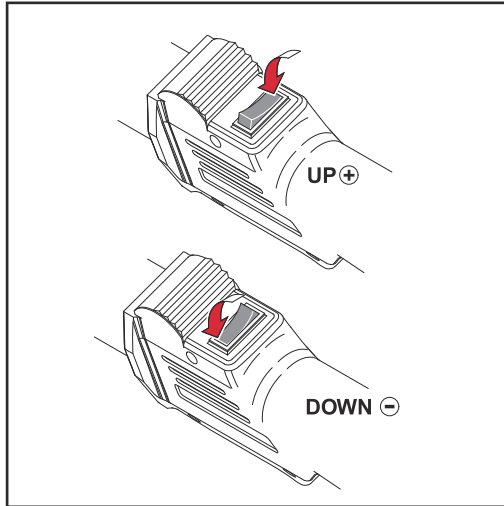

Montar as peças de desgaste no corpo da tocha de solda

MTG d, MTW d -
Montar as peças
de desgaste no
corpo da tocha
de solda

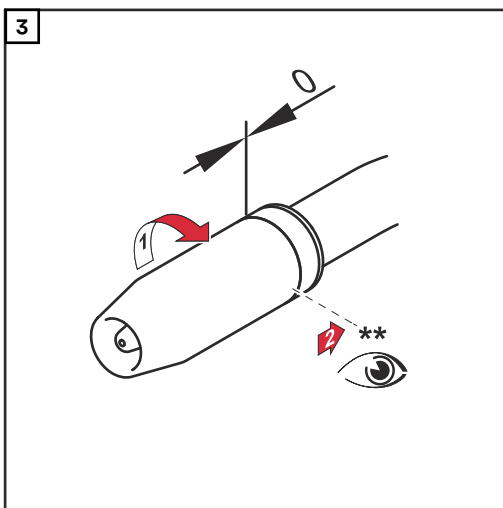
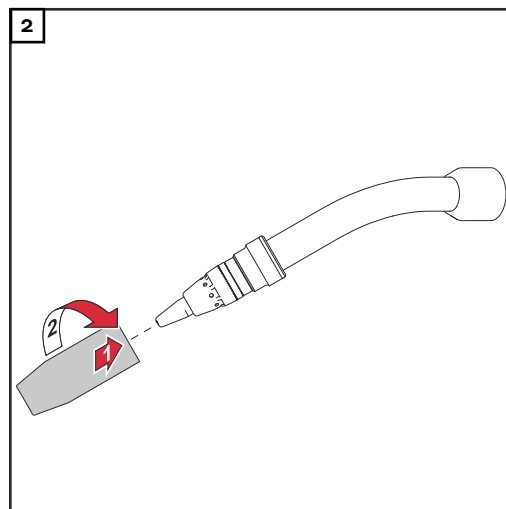
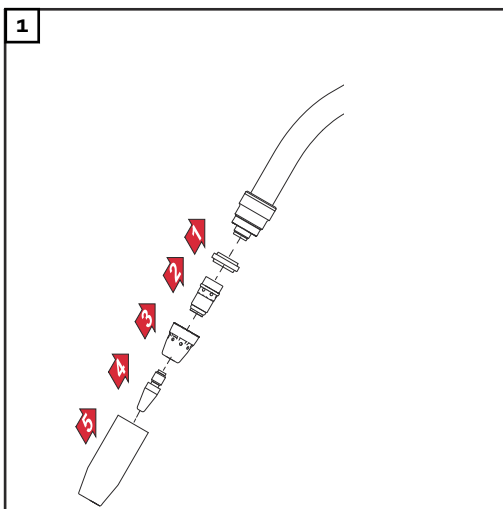

** Apertar o bico de gás até o en-
costo

MTG 400d K4,
MTW 500d K4 -
montar as peças
de desgaste

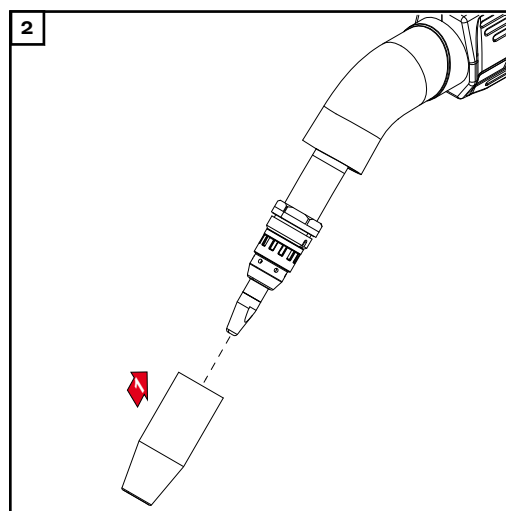
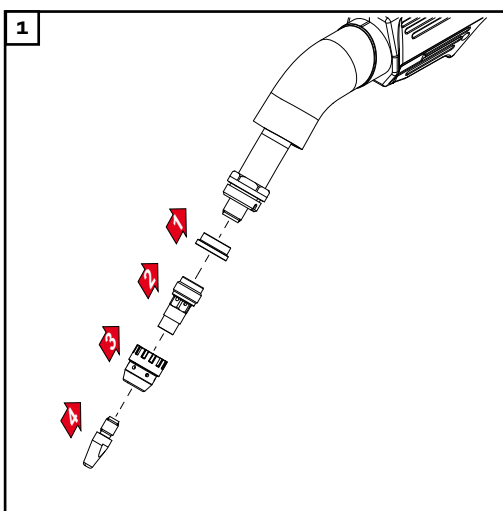

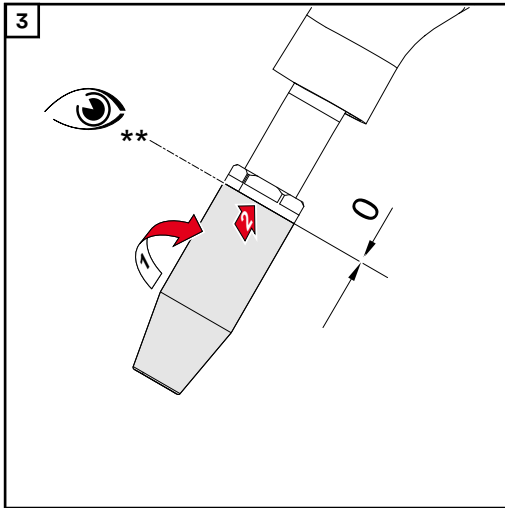

** Apertar o bico de gás até o encosto

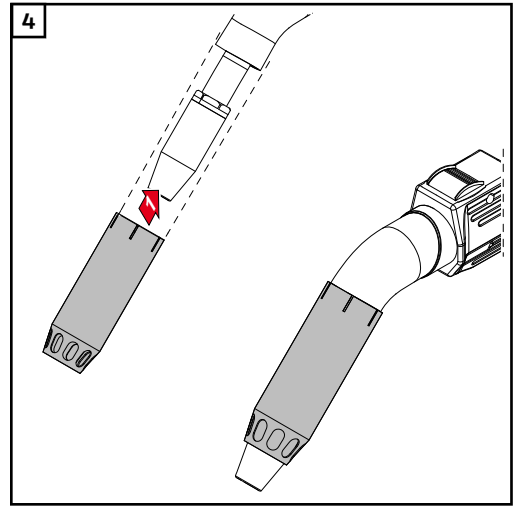

Colocar o bico de sucção

Montar o corpo da tocha de solda ML no jogo de mangueira MHP

Montar tocha de solda Multilock

AVISO!

Perigo de danos à tocha de solda. Parafusar firmemente o corpo da tocha de solda sempre até o encosto.

AVISO!

Em tochas de solda refrigeradas a água pode surgir uma resistência aumentada ao aparafusar firmemente a porca de capa, devido ao modo de construção da tocha de solda. Isto é normal. Parafusar firmemente o corpo da tocha de solda sempre até o encosto.

AVISO!

Antes da montagem de um corpo da tocha de solda, garantir que a posição de acoplamento do corpo da tocha de solda e do jogo de mangueira esteja intacta e limpa.

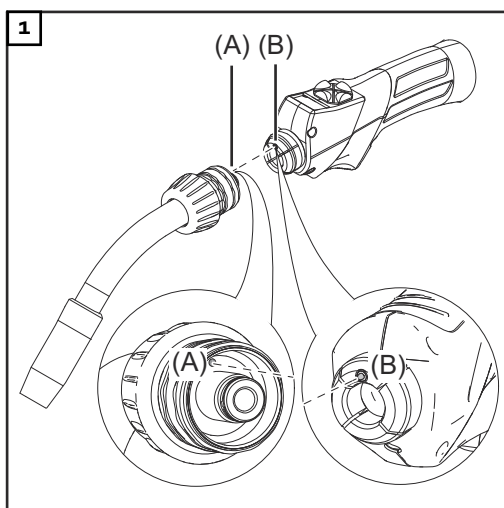

AVISO!

Quando o pino-guia (A) do jogo de mangueira chega aos orifícios de ajuste (B), o corpo da tocha de solda se encontra na posição 0°.

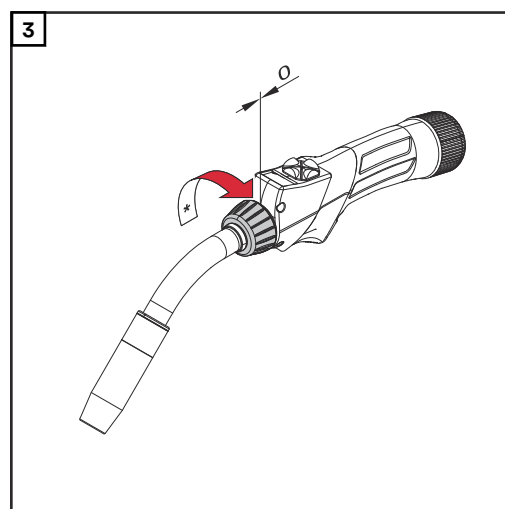
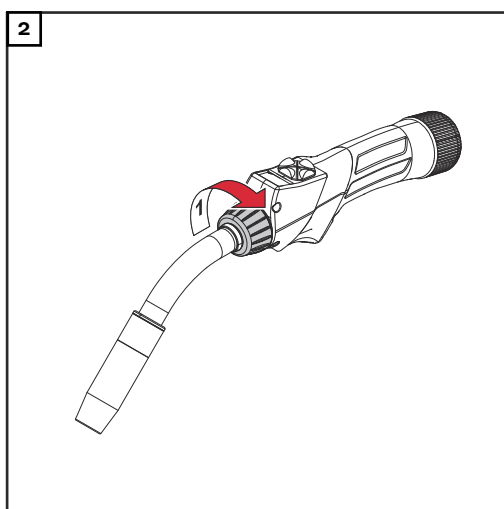

* Garantir que a porca de capa foi parafusada firmemente até o encosto.

Instalar os fios de revestimento interior

Verificação do bocal de fixação

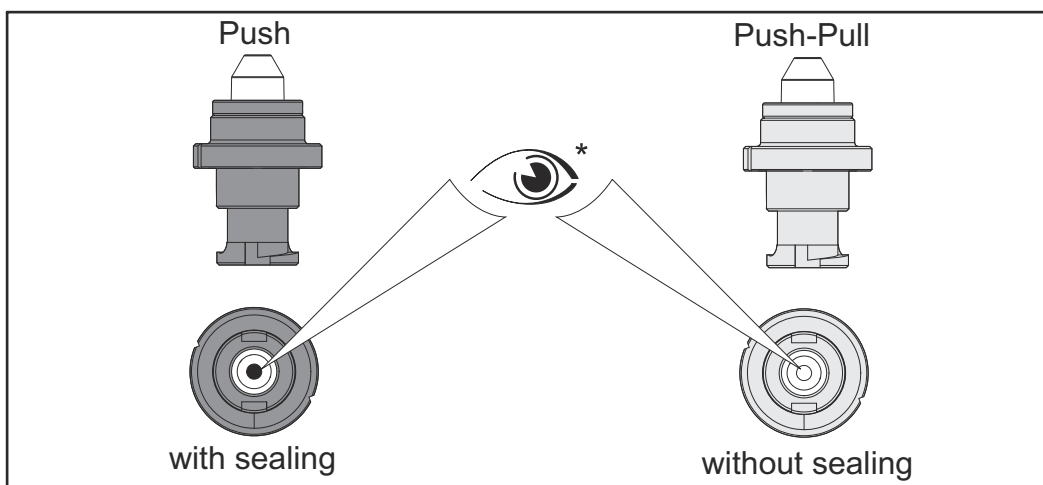

* Verifique o bocal de fixação antes do comissionamento e toda vez que o núcleo de guia de arame for trocado. Para isso, faça uma inspeção visual:

- esquerda: Bocal de fixação de latão com arruela de vedação. Não é possível enxergar pela arruela de vedação.
- direita: bocal de fixação prateado com passagem visível

AVISO!

Bocal de fixação incorreto ou com defeito em aplicações de pressão

O resultado é a perda de gás e características de soldagem ruins

- ▶ Use bocais de fixação de latão para minimizar a perda de gás
- ▶ verifique se a arruela de vedação está intacta

AVISO!

Bocal de fixação incorreto em aplicações Push-Pull

Enrolamento de arame e aumento de abrasão no núcleo de guia de arame ao usar um bocal de fixação com arruela de vedação

- ▶ use o bocal de fixação prateado para facilitar a condução do arame

Instalar o fio de revestimento interior de aço

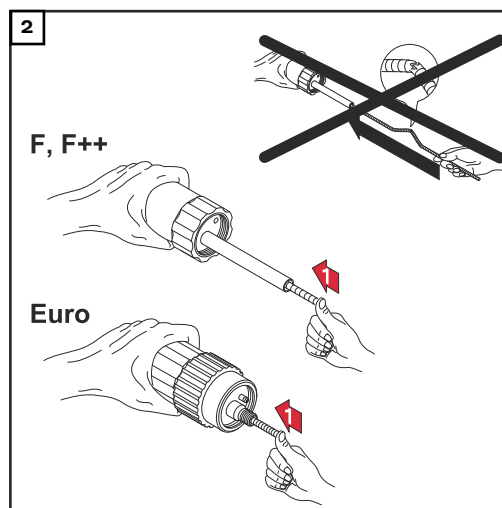
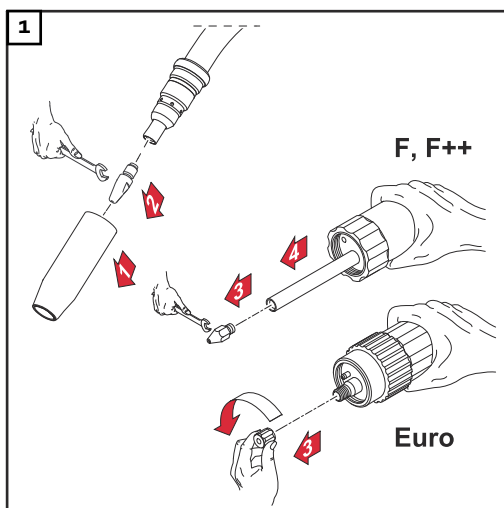

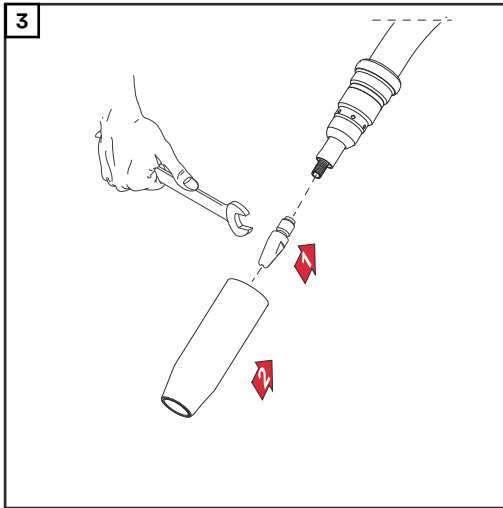

F++, F:

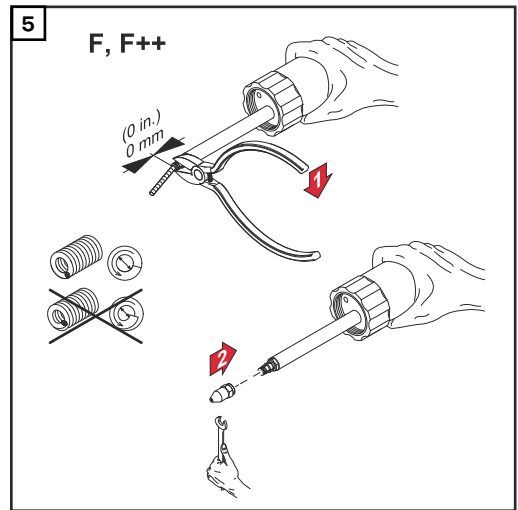
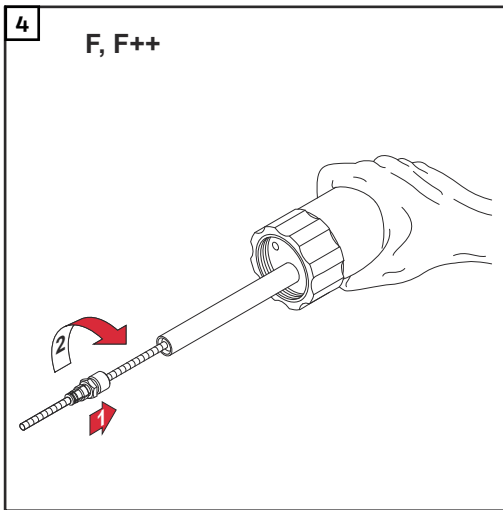

Euro:

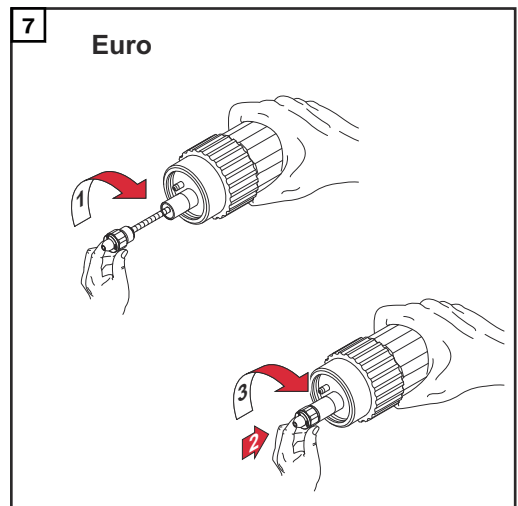
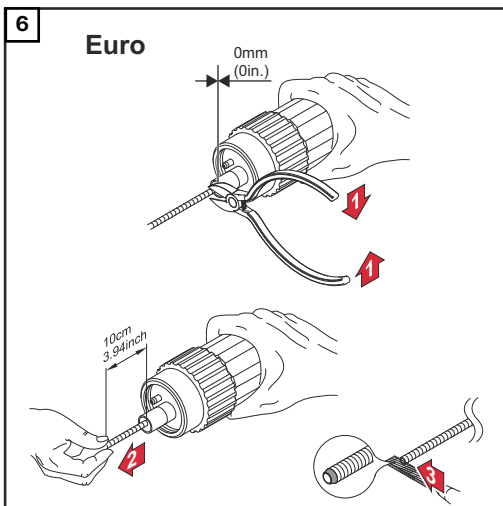

Instalar o fio de revestimento interior de plástico (F, F++)

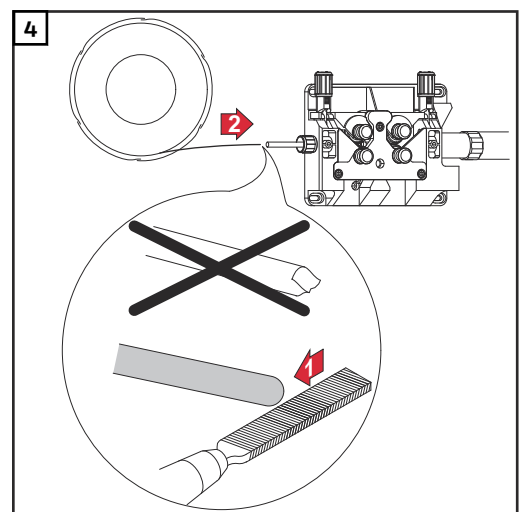
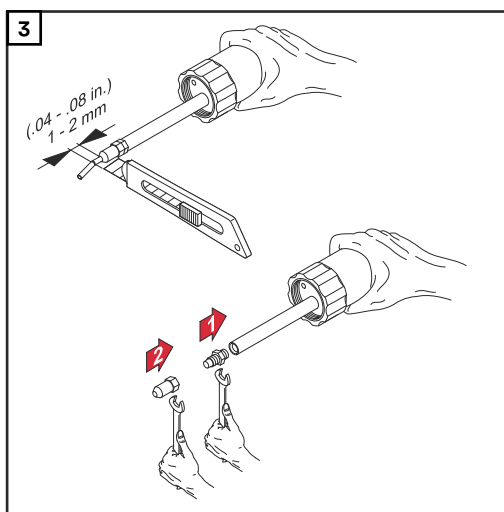
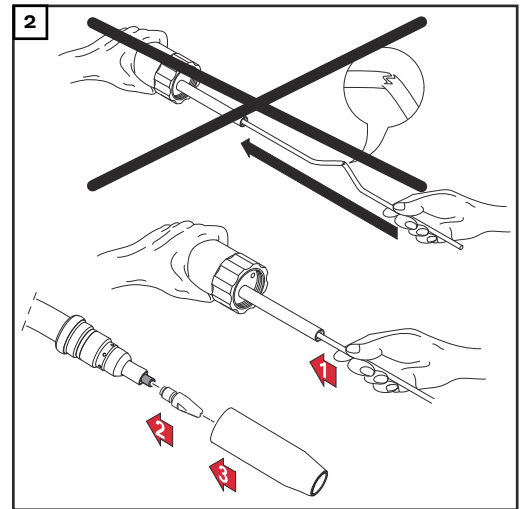
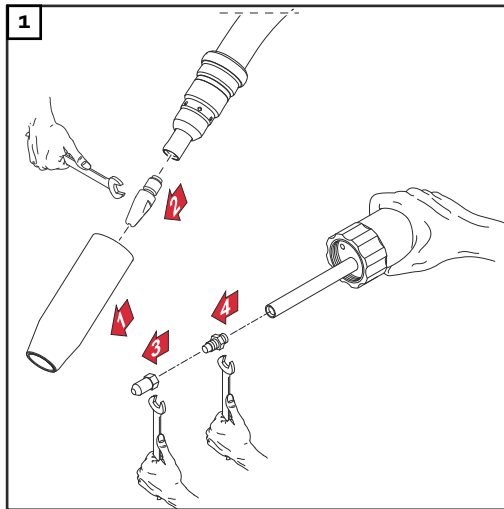

PT-BR

Montar o revestimento de plástico (conexão-Fro-nius com bocal de guia-arame)

AVISO!

Antes de inserir o eletrodo de arame, arredondar a extremidade dos eletrodos de arame.

Vale para os conduites de teflon, as combinações de revestimento e os revestimentos de grafite

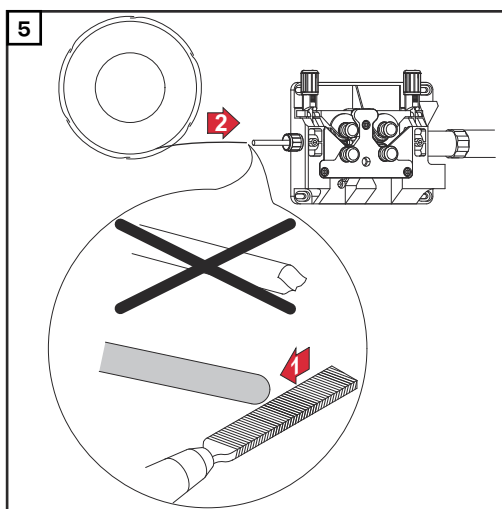
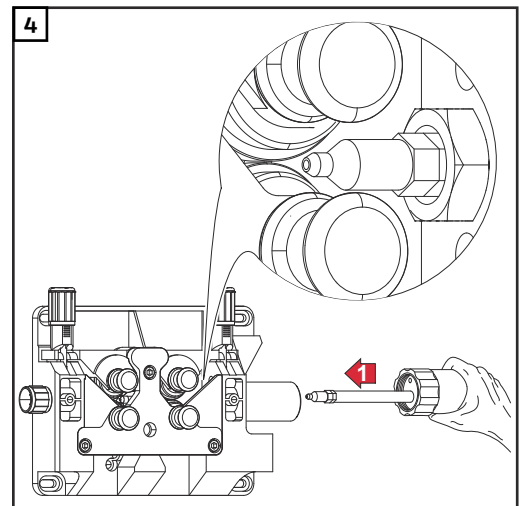
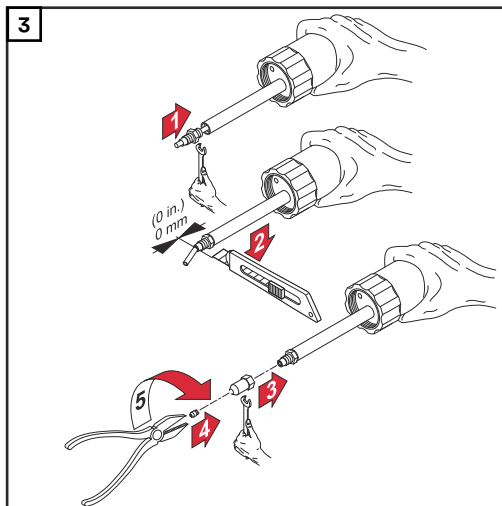
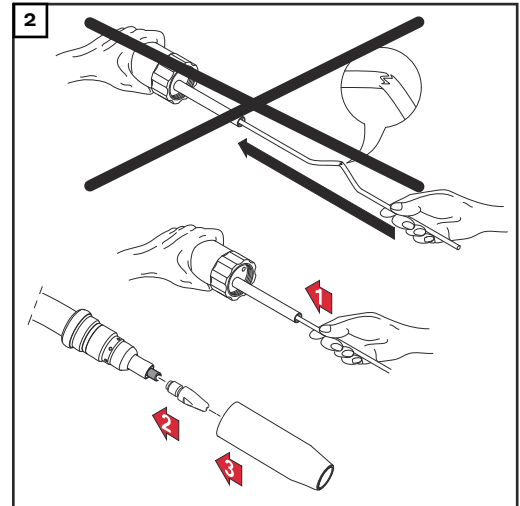
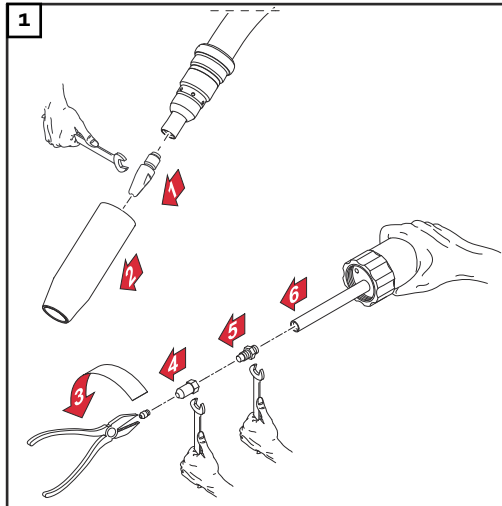

Instalar o fio de revestimento interior de plástico (Euro)

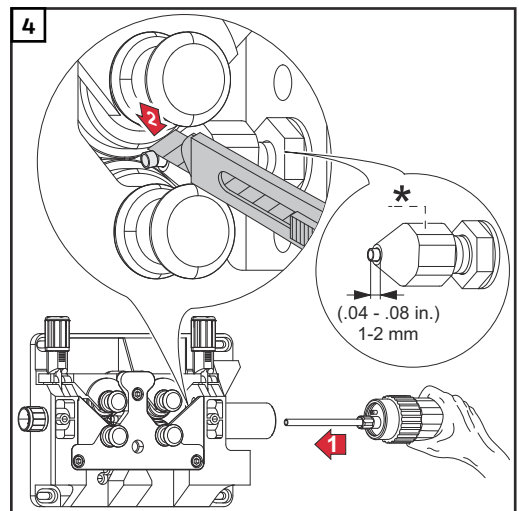
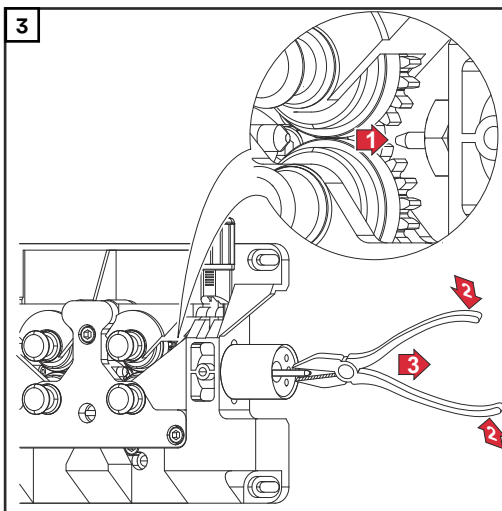
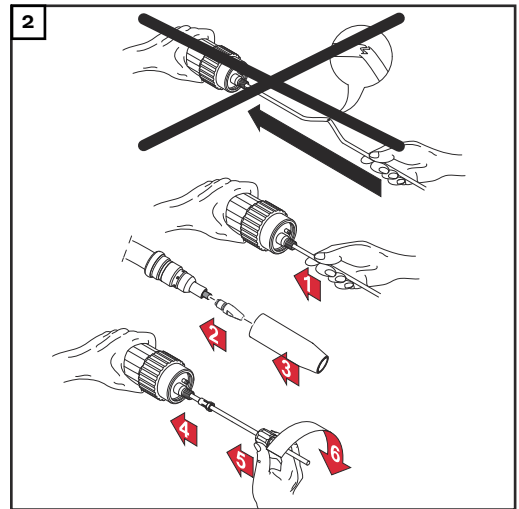
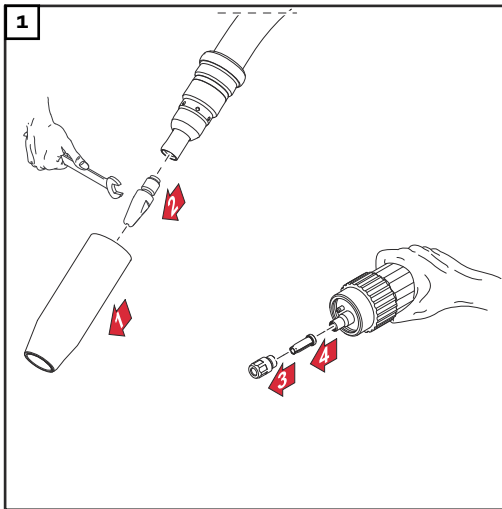

* Opção de bocal de entrada (42,0001,5421)

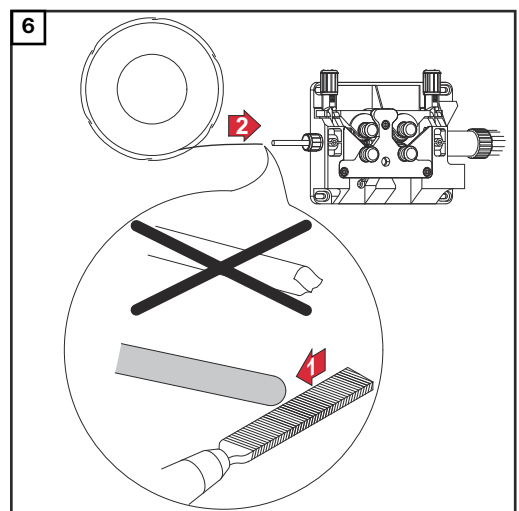
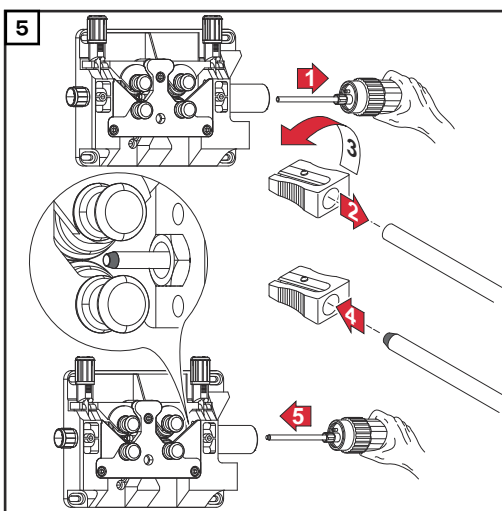

Comissionamento

Conectar a tocha de solda

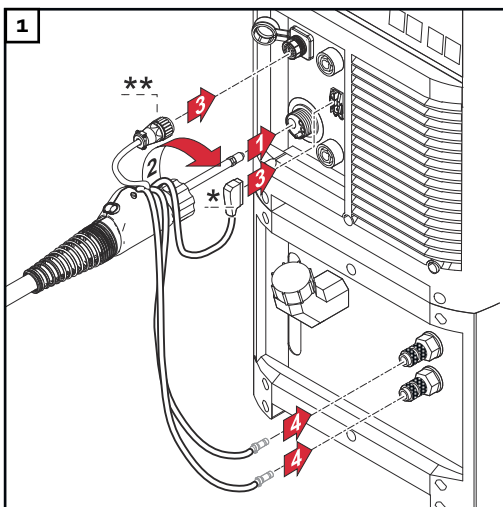

- * Conector LocalNet (tocha de solda padrão ou up/down)
- ** Conector JobMaster (tocha de solda JobMaster)

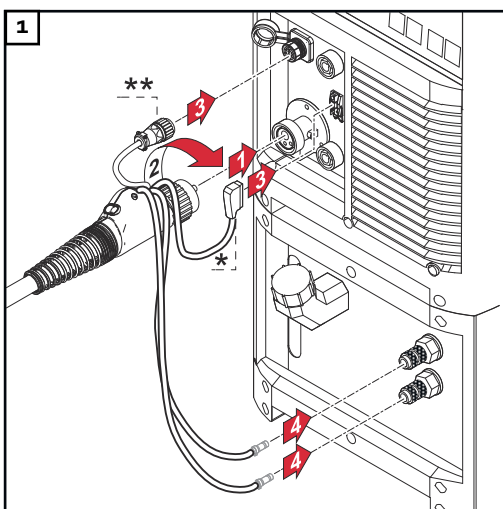

- * Conector LocalNet (tocha de solda padrão ou up/down)
- ** Conector JobMaster (tocha de solda JobMaster)

Ligar a sucção

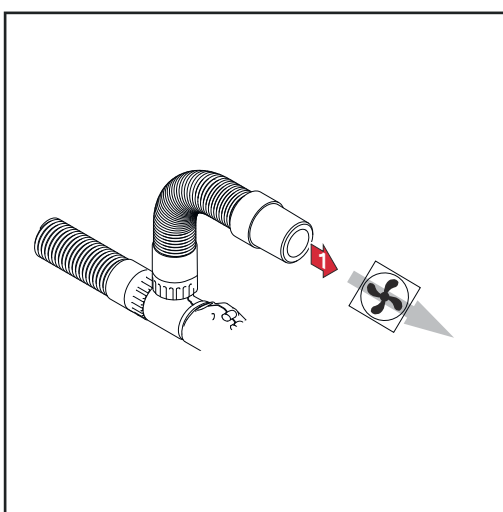

- 1 Ligue a mangueira de sucção ao aparelho de sucção em conformidade com os valores de referência do aparelho

Torcer o corpo da tocha de solda Multilock

⚠ CUIDADO!

Risco de queimaduras por refrigerante e corpos das tochas de solda quentes.

- ▶ Antes do início de trabalhos, deixar o refrigerante e o corpo da tocha de solda resfriarem em temperatura ambiente (+25 °C, +77 °F).

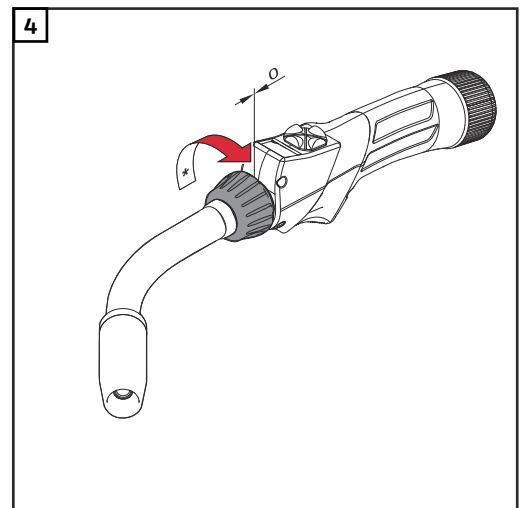
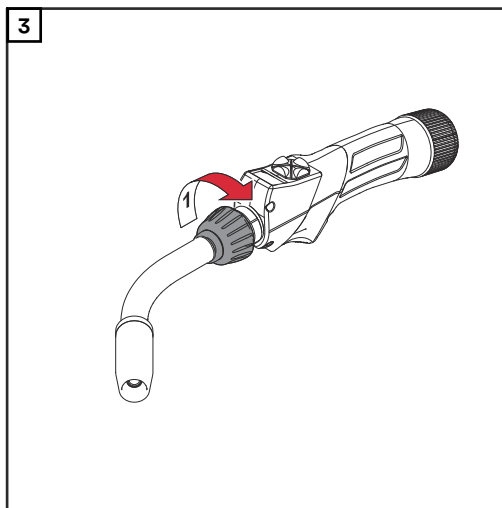
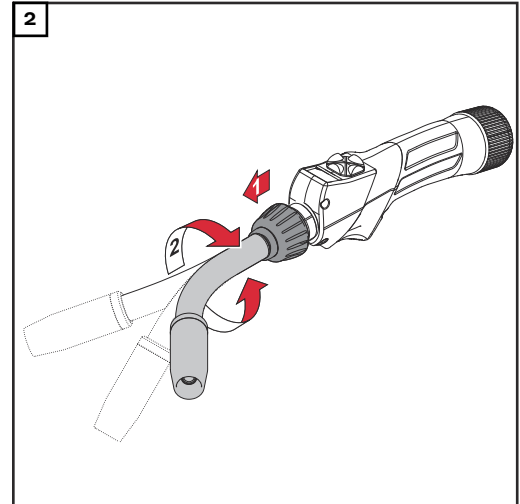
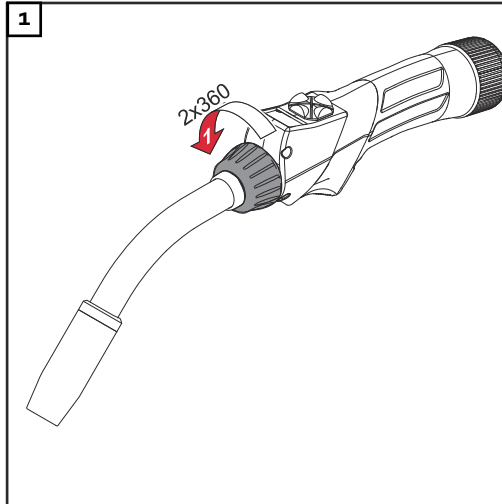

- * Garantir que a porca de capa foi parafusada firmemente até o encosto.

Substituir o corpo da tocha de solda Multilock

⚠ CUIDADO!

Risco de queimaduras por refrigerante e corpos das tochas de solda quentes.
Escaldaduras graves podem ser provocadas.

- ▶ Antes do início de trabalhos, deixar o refrigerante e o corpo da tocha de solda resfriarem em temperatura ambiente (+25 °C, +77 °F).

AVISO!

No corpo da tocha de solda há sempre um resto de refrigerante.

Desmontar o corpo da tocha de solda somente quando o bico de gás indicar para baixo.

AVISO!

Antes da montagem de um corpo da tocha de solda, garantir que a posição de acoplamento do corpo da tocha de solda e do jogo de mangueira esteja intacta e limpa.

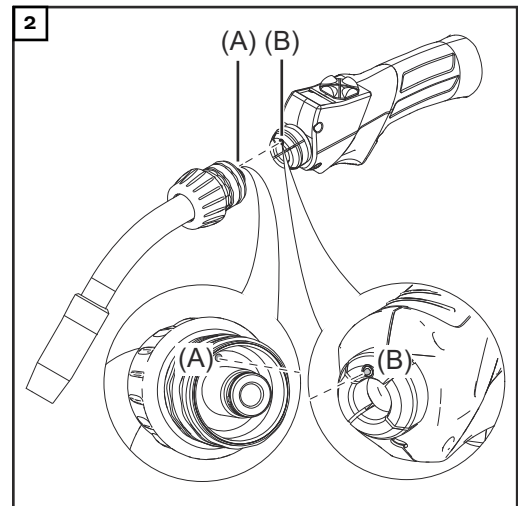
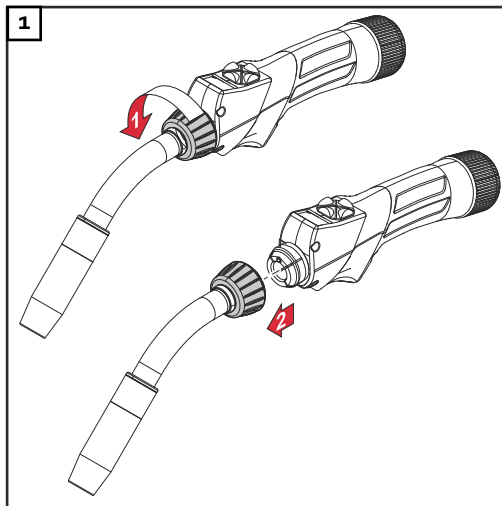

AVISO!

Quando o pino-guia (A) do jogo de mangueira chega aos orifícios de ajuste (B), o corpo da tocha de solda se encontra na posição 0°.

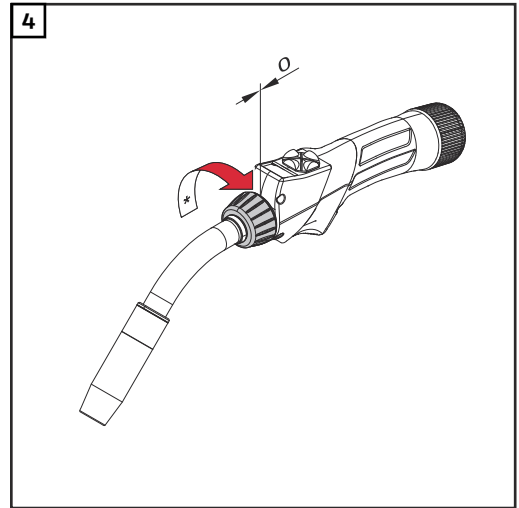
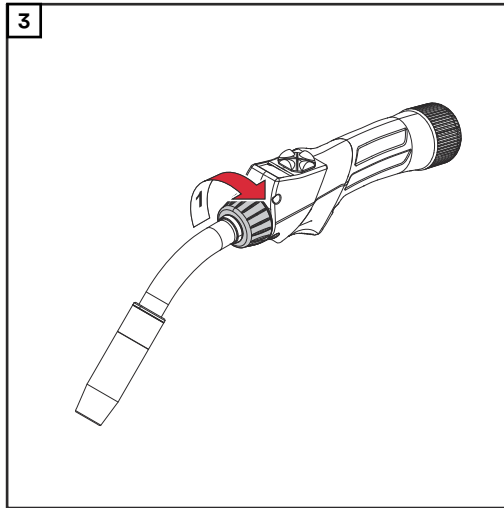

* Garantir que a porca de capa foi parafusada firmemente até o encosto.

Suporte de prisma para tocha de máquinas

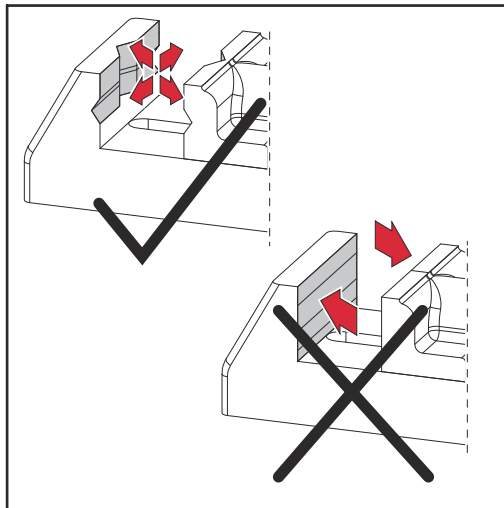

Somente inserir a tocha de máquinas para processamento em um suporte adequado de prisma!

Conservação e manutenção

Informações gerais

A manutenção regular e preventiva da tocha de solda é um fator importante para uma operação sem falhas. A tocha de solda é submetida a altas temperaturas e muita sujeira. Por isso, a tocha de solda precisa de uma manutenção mais frequente do que outros componentes do sistema de soldagem.

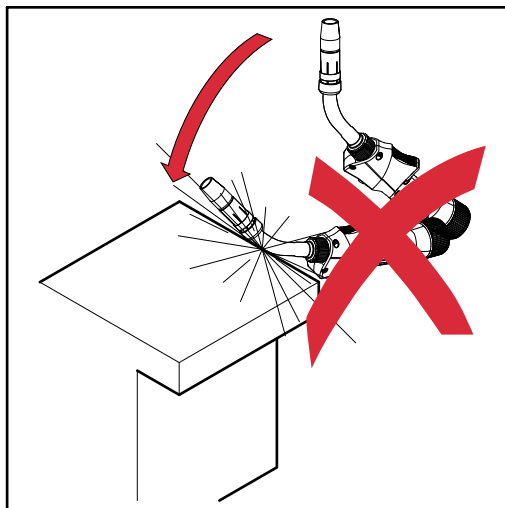

CUIDADO!

Risco de danos devido ao manuseio inadequado da tocha de solda.

Pode resultar em danos materiais graves.

- ▶ Não bater com a tocha de solda em objetos duros.
- ▶ Evite fazer marcações e arranhar o tubo de contato.
- ▶ Não dobrar o tubo curvado em nenhuma circunstância.

Reconhecimento de peças de desgaste defeituosas

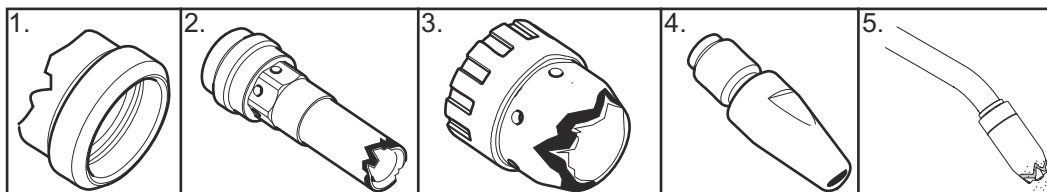

1. Peças de isolamento
 - Bordas externas queimadas, entalhes
2. Bocais
 - Bordas externas queimadas, entalhes
 - Com muitos respingos de solda
3. Proteção contra respingos
 - Bordas externas queimadas, entalhes
4. Tubos de contato
 - Furos de entrada e saída de arame desgastados (ovais)
 - Com muitos respingos de solda
 - Penetração de solda na ponta do tubo de contato
5. Bicos de gás
 - Com muitos respingos de solda
 - Bordas externas queimadas
 - Entalhes

Manutenção em todo comissionamento

- Controlar peças de desgaste
 - substituir peças de desgaste defeituosas
- Deixar o bico de gás livre de respingos de solda

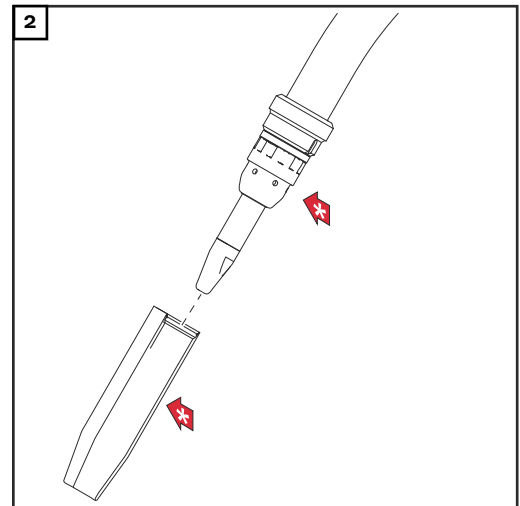
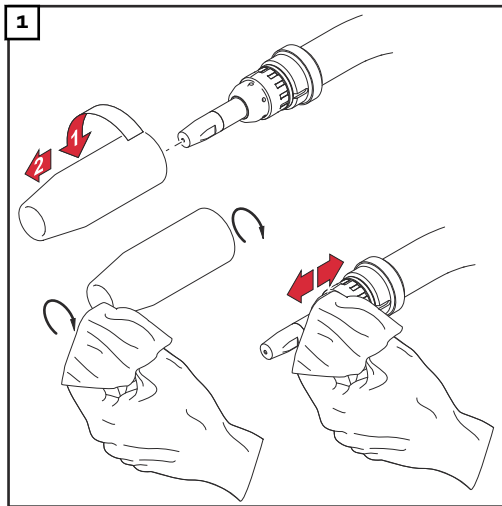

- * Verificar bico de gás, proteção contra respingos e isolamentos quanto a danos, e substituir componentes danificados.
- Além disso, em cada comissionamento, nas tochas de solda resfriadas a água:
 - garantir que todas as conexões do refrigerador estejam vedadas
 - garantir que haja um fluxo de retorno adequado do refrigerador

Manutenção a cada substituição das bobinas de arame/de cesta

- Limpar a mangueira de transporte de arame com ar comprimido reduzido
- Recomendável: Trocar fio de revestimento interior, antes da nova instalação do fio de revestimento interior, limpar as peças de desgaste

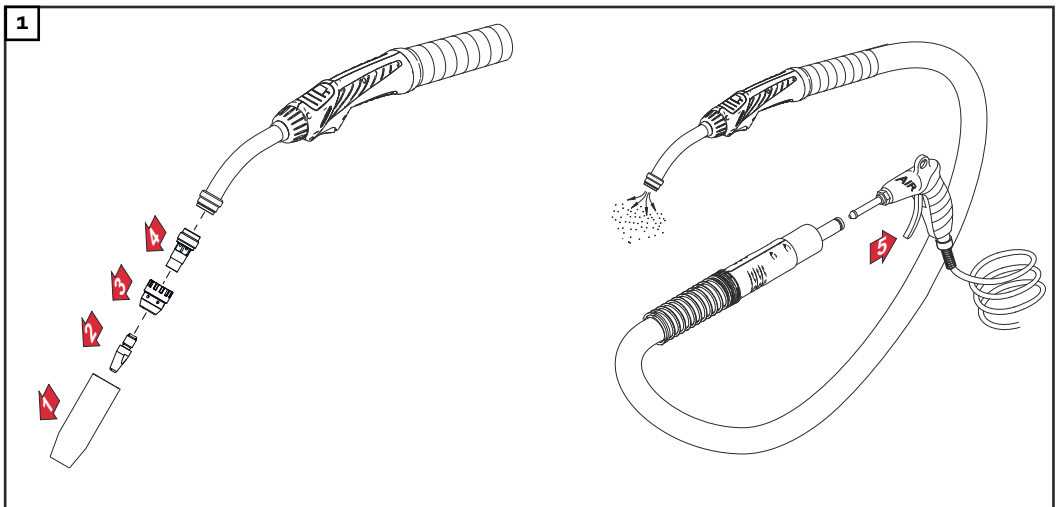

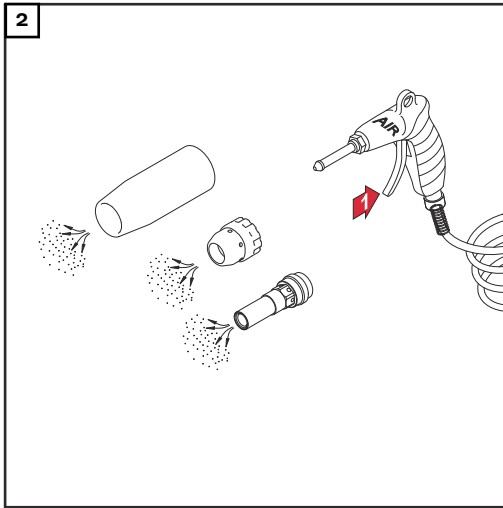

Diagnóstico de erro, eliminação de erro

Diagnóstico de erro, eliminação de erro

Sem corrente de soldagem

Interruptor da rede da fonte de solda ligado, indicações acesas na fonte de solda, gás de proteção disponível

Causa: Conexão de massa incorreta

Solução: Estabelecer a conexão de massa adequadamente

Causa: Cabo de corrente na tocha de solda interrompido

Solução: Substituir a tocha de solda

Sem função após apertar a tecla de queima

Interruptor da rede da fonte de solda ligado, indicações acesas na fonte de solda

Causa: FSC ('Sistema de conexão Fronius' - Conexão central) não inserida até o encosto

Solução: Inserir o sistema de conexão Fronius até encosto

Causa: Tocha de solda ou linha de controle da tocha de solda defeituoso

Solução: Substituir a tocha de solda

Causa: Jogo de mangueira de conexão não conectado adequadamente ou defeituoso

Solução: Conectar o jogo de mangueira de conexão adequadamente
Substituir jogo de mangueira de conexão defeituoso

Causa: Fonte de solda com defeito

Solução: Entrar em contato com a assistência técnica

Sem gás de proteção

todas as outras funções estão disponíveis

Causa: Cilindro de gás vazio

Solução: Substituir o cilindro de gás

Causa: Válvula redutora de pressão com defeito

Solução: Substituir válvula redutora de pressão/gás

Causa: Mangueira de gás não montada, dobrada ou danificada

Solução: Montar a mangueira de gás, colocar de forma reta. Substituir mangueira de gás defeituosa

Causa: Tocha de solda com defeito

Solução: Substituir a tocha de solda

Causa: Válvula solenoide de gás com defeito

Solução: Entrar em contato com a assistência técnica (trocar válvula solenoide de gás)

Características de soldagem ruins

- Causa: Parâmetros de soldagem incorretos
Solução: Corrija as configurações
- Causa: Conexão à terra ruim
Solução: Produza um bom contato com a peça de trabalho
- Causa: Nenhum ou pouco gás de proteção
Solução: Verifique o regulador de pressão, a mangueira de gás, a válvula solenóide de gás e a conexão de gás da tocha de solda. Em tochas com refrigerador a gás, verifique a vedação do gás e use um núcleo de guia de arame adequado
- Causa: Tocha de solda com vazamento
Solução: Substitua a tocha de solda
- Causa: Tubo de contato muito grande ou desgastado
Solução: Substitua o tubo de contato
- Causa: Liga de arame ou diâmetro de arame incorreto
Solução: Verifique o arame introduzido / a cesta-tipo carretel
- Causa: Liga de arame ou diâmetro de arame incorreto
Solução: Verifique a capacidade de soldagem da matéria-prima básica
- Causa: Gás de proteção inadequado para a liga de arame
Solução: Utilize o gás de proteção correto
- Causa: Condições de soldagem desfavoráveis: Gás de proteção com impurezas (umidade, ar), blindagem de gás com defeito (o banho de solda „ferve“, ar circulante), impurezas na peça de trabalho (ferrugem, tinta, graxa)
Solução: Otimize as condições de soldagem
- Causa: O gás de proteção escapa do bocal de fixação
Solução: use o bocal de fixação correto
- Causa: A arruela de vedação do bocal de fixação está com defeito, o gás de proteção escapa pelo bocal de fixação
Solução: Substitua o bocal de fixação para garantir a estanqueidade do gás
- Causa: Respingos de solda no bico de gás
Solução: Remova os respingos de solda
- Causa: Turbulências por causa de quantidade excessiva de gás de proteção
Solução: Reduza a quantidade de gás de proteção, recomendável:
quantidade de gás de proteção (l/min) = diâmetro do arame (mm) x 10
(por exemplo, 16 l/min para 1,6 mm de eletrodo de arame)
- Causa: Distância muito grande entre a tocha de solda e a peça de trabalho
Solução: Reduza a distância entre a tocha de solda e a peça de trabalho
(aprox. 10 - 15 mm / 0.39 - 0.59 in.)

Causa: Ângulo de ataque da tocha de solda grande demais

Solução: Reduza o ângulo de ataque da tocha de solda

Causa: Componentes de alimentação de arame não correspondem ao diâmetro do eletrodo de arame / o material do eletrodo de arame

Solução: Use os componentes corretos de alimentação de arame

Alimentação ruim de arame

Causa: Dependendo do sistema, o freio no avanço de arame ou na fonte de solda está muito apertado

Solução: Ajustar o freio mais solto

Causa: Orifício do tubo de contato entupido

Solução: Substituir o tubo de contato

Causa: O núcleo de guia de arame ou o inserto da condução de arame está com defeito

Solução: Verifique o núcleo de guia de arame ou o inserto de condução do arame quanto a dobras, sujeira, etc.

Núcleo de guia de arame com defeito, substitua o inserto de condução de arame com defeito

Causa: Rolos de alimentação inadequados para o eletrodo de arame utilizado

Solução: Utilize rolos de alimentação adequados

Causa: Pressão de contato incorreta dos rolos de alimentação

Solução: Otimize a pressão de contato

Causa: Rolos de alimentação sujos ou danificados

Solução: Limpe ou substitua os rolos de alimentação

Causa: Núcleo da guia de arame mal posicionado ou dobrado

Solução: Substitua o núcleo da guia de arame

Causa: Núcleo da guia de arame muito curto após o corte

Solução: Substitua o núcleo da guia de arame e corte o novo núcleo da guia de arame no comprimento correto

Causa: Abrasão do eletrodo de arame devido à pressão de contato excessiva nos rolos de alimentação

Solução: Reduza a pressão de contato nos rolos de alimentação

Causa: Eletrodo de arame sujo ou com ferrugem

Solução: Utilize eletrodo de arame de alta qualidade sem impurezas

Causa: Em núcleos de guia de arame feitos de aço: núcleo de guia de arame não revestido em uso

Solução: Use núcleo de guia de arame revestido

Causa: A área de entrada e saída de arame do bocal de fixação está deformada (oval, desgastada), o gás de proteção escorre pelo bocal de fixação

Solução: Substitua o bocal de fixação para garantir a estanqueidade do gás

O bico de gás esquentava muito

Causa: Nenhum desvio de calor por causa do assento solto do bico de gás

Solução: Parafusar firmemente o bico de gás até o encosto

A tocha de solda esquentava muito

Causa: Somente para tocha de solda Multilock: Porca de capa do corpo da tocha de solda solta

Solução: Apertar a porca de capa

Causa: Tocha de solda foi operada acima da corrente de soldagem máxima

Solução: Reduzir a energia de soldagem ou utilizar a tocha de solda com a capacidade correta

Causa: Tocha de solda dimensionada muito fraca

Solução: Observar o ciclo de trabalho e os limites de carga

Causa: Somente em instalações com refrigeração a água: Fluxo de agente refrigerante insuficiente

Solução: Verificar o nível de refrigerante, fluxo de refrigerante, impurezas do refrigerante, entupimento do jogo de mangueira, etc.

Causa: Ponta da tocha de solda muito perto do arco voltaico

Solução: Aumentar stickout

Vida útil curta do tubo de contato

Causa: Rolos de alimentação incorretos

Solução: Utilizar rolos de alimentação corretos

Causa: Fricção no eletrodo de arame por causa de pressão de contato forte demais nos rolos de alimentação

Solução: Reduzir a pressão de contato nos rolos de alimentação

Causa: Eletrodo de arame sujo / com ferrugem

Solução: Utilizar eletrodo de arame de alta qualidade sem impurezas

Causa: Eletrodo de arame sem revestimento

Solução: Utilizar eletrodo de arame com revestimento adequado

Causa: Dimensão incorreta do tubo de contato

Solução: Dimensionar corretamente o tubo de contato

Causa: Ciclo de trabalho da tocha de solda longo demais

Solução: Reduzir o ciclo de trabalho ou utilizar tocha de solda mais potente

Causa: Tubo de contato superaquecido. Nenhum desvio de calor por causa de tubo de contato muito frouxo

Solução: Apertar o tubo de contato

AVISO!

Em aplicações de CrNi, pode ocorrer um desgaste maior do tubo de contato por causa das características da superfície do eletrodo de arame de CrNi.

Funcionamento da tecla de queima com defeito

- Causa: Conector entre a tocha de solda e fonte de solda incorreto
Solução: Estabelecer a conexões adequadamente/ enviar a fonte de solda ou a tocha de solda para assistência técnica
- Causa: Impurezas entre a tecla de queima e a carcaça da tecla de queima
Solução: Remover as impurezas
- Causa: Linha de controle defeituosa
Solução: Entrar em contato com a assistência técnica

Porosidade na costura de soldagem

- Causa: Formação de respingos no bico de gás, por isso a proteção de gás da costura de soldagem é insuficiente
Solução: Remover os respingos de solda
- Causa: Furos ou conexão incorreta da mangueira de gás
Solução: Trocar a mangueira de gás
- Causa: O o-ring na conexão central está cortado ou com defeito
Solução: Trocar o o-ring
- Causa: Umidade/condensação no tubo de gás
Solução: Secar tubo de gás
- Causa: Fluxo de gás muito forte ou muito fraco
Solução: Corrigir fluxo de gás
- Causa: Quantidade de gás insuficiente no início ou no fim de soldagem
Solução: Aumentar o fornecimento de gás e o pós-fluxo de gás
- Causa: Ferrugem ou má qualidade do eletrodo de arame
Solução: Utilizar eletrodo de arame de alta qualidade sem impurezas
- Causa: Válido para as tochas com refrigerador a gás: Saída no fio de revestimento interior não isolado
Solução: Em tochas com refrigerador a gás, devem ser utilizados apenas fios de revestimento interior isolados
- Causa: Aplicação de agente separador em excesso
Solução: Retirar o agente separador em excesso/aplicar menos agente separador
- Causa: Sucção muito forte
Solução: Reduzir a sucção

Sucção muito baixa

Causa: Furos na mangueira de sucção

Solução: Restaurar a mangueira de sucção

Causa: Filtros incorretos do aparelho de sucção

Solução: Restaurar os filtros do aparelho de sucção

Causa: Fluxo de ar interrompido

Solução: Eliminar a obstrução

Causa: Pouca sucção do aparelho de sucção,
configuração incorreta do OPT/i FumeEx

Solução: Use um dispositivo de sucção com maior sucção,
aumente a sucção

Dados técnicos

Geral

Dimensionamento de tensão (V-Peak):

- para tochas de solda manuais: 113 V
- para tochas de solda mecânicas: 141 V

Dados técnicos da tecla de queima:

- $T_{\text{máx.}} = 5 \text{ V}$
- $C_{\text{máx}} = 10 \text{ mA}$

A operação da tecla de queima é permitida apenas no que se refere a dados técnicos.

O produto está em conformidade com as exigências da norma IEC 60974-7 / - 10 CI. A.

Tocha de solda refrigerado a gás - MTG 250d - 500d

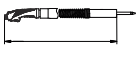
	MTG 250d	MTG 320d	MTG 400d	MTG 500d
I (amp.) 10 min/40° C CO ²	40% CT* 250 60% CT* 200 100% CT* 170	40% CT* 320 60% CT* 260 100% CT* 210	40% CT* 400 60% CT* 320 100% CT* 260	40% CT* 500 60% CT* 400 100% CT* 320
I (amp.) 10 min/40° C M21	40% CT* 200 60% CT* 160 100% CT* 120	40% CT* 260 60% CT* 210 100% CT* 160	40% CT* 320 60% CT* 260 100% CT* 210	40% CT* 400 60% CT* 320 100% CT* 260
 [mm (in.)]	0,8-1,2 (.032-.047)	0,8-1,6 (.032-.063)	1,0-1,6 (.039-.063)	1,0-1,6 (.039-.063)
 [m (ft.)]	3,5 / 4,5 (12 / 15)	3,5 / 4,5 (12 / 15)	3,5 / 4,5 (12 / 15)	3,5 / 4,5 (12 / 15)

*CT = Ciclo de trabalho

Corpo da tocha de solda refrigerada a gás - tubo curvado MIG/MAG 250i, 320i, 330i, 400i, 550i G ML

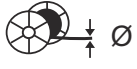

	Tubo curvado MIG/MAG 250i G ML	Tubo curvado MIG/MAG 320i G ML	Tubo curvado MIG/MAG 330i G ML
I (ampère) 10 min/ 40 °C M21+C1 (EN 439)	40 % ED* 250 60 % ED* 200 100 % ED* 170	40 % ED* 320 60 % ED* 260 100 % ED* 210	40 % ED* 330 60 % ED* 270 100 % ED* 220
 [mm (in.)]	0,8-1,2 (0.032-0.047)	0,8-1,6 (0.032-0.063)	0,8-1,6 (0.032-0.063)

ED = ciclo de trabalho

	Tubo curvado MIG/MAG 400i G ML	Tubo curvado MIG/MAG 550i G ML
I (ampère) 10 min/ 40 °C C1 (EN 439)	-	30 % ED* 550
I (ampère) 10 min/ 40 °C M21 (EN 439)	-	30 % ED* 520
I (ampère) 10 min/ 40 °C M21+C1 (EN 439)	40 % ED* 400 60 % ED* 320 100 % ED* 260	- 60 % ED* 420 100 % ED* 360
 [mm (in.)]	0,8-1,6 (0.032-0.063)	0,8-1,6 (0.032-0.063)



ED = ciclo de trabalho

**Jogo de man-
gueira refrigera-
do a gás - MHP
400d G ML**

	MHP 400d G ML
I (ampère) 10 min/40 °C CO ²	40% CT* 400 60% CT* 320 100% CT* 260
I (ampère) 10 min/40 °C M21	40% CT* 320 60% CT* 260 100% CT* 210
 [mm (in.)]	0,8-1,6 (.032-.063)
 [m (ft.)]	3,35 / 4,35 (11 / 14)







* CT = ciclo de trabalho

**Jogo de man-
gueira refrigera-
do a gás - MHP
500d G ML M**

	MHP 500d G ML M
I (amp.) 10 min/40 °C CO ²	40% CT* 500 60% CT* 400 100% CT* 320
I (amp.) 10 min/40 °C M21	40% CT* 400 60% CT* 320 100% CT* 260
 [mm (in.)]	0,8-1,6 (.032-.063)
 [m (ft.)]	1,35 / 2,35 / 3,35 (4.4 / 7.7 / 14)

* CT = ciclo de trabalho



Tocha de solda refrigerado a água - MTW 250d - 700d

	MTW 250d	MTW 400d	MTW 500d	MTW 700d
I (ampère) 10 min/40° C CO ²	100% CT* 250	100% CT* 400	100% CT* 500	100% CT* 700
I (ampère) 10 min/40° C M21	100% CT* 200	100% CT* 320	100% CT* 400	100% CT* 560
 [mm (in.)]	0,8-1,2 (.032-.047)	0,8-1,6 (.032-.063)	0,8-1,6 (.032-.063)	0,8-1,6 (.032-.063)
Q _{min}  [l/min (gal./min)]	1 (.26)	1 (.26)	1 (.26)	1 (.26)
P _{min}  [W]**	500 (3,5 m) 600 (4,5 m)	800 (3,5 m) 950 (4,5 m)	1400 (3,5 m) 1700 (4,5 m)	1800 (3,5 m) 2200 (4,5 m)
P _{min}  [bar (psi.)]	3 (43)	3 (43)	3 (43)	3 (43)
P _{max}  [bar (psi.)]	5 (72)	5 (72)	5 (72)	5 (72)
 [m (ft.)]	3,5 / 4,5 (12 / 15)	3,5 / 4,5 (12 / 15)	3,5 / 4,5 (12 / 15)	3,5 / 4,5 (12 / 15)

*CT = Ciclo de trabalho

** Menor capacidade de refrigeração conforme norma IEC 60974-2

Corpo da tocha de solda refrigerada a água - tubo curvado MIG/MAG 250i, 330i, 400i, 500i, 700i W ML

	Tubo curvado MIG/MAG 250i W ML	Tubo curvado MIG/MAG 330i W ML	Tubo curvado MIG/MAG 400i W ML	Tubo curvado MIG/MAG 500i W ML
I (ampère) 10 min/ 40 °C M21+C1 (EN 439)	100 % ED* 250	100 % ED* 330	100 % ED* 400	100 % ED* 500
 [mm (in.)]	0,8-1,2 (0.032-0.047)	0,8-1,6 (0.032-0.063)	0,8-1,6 (0.032-0.063)	1,0-1,6 (0.039-0.063)
Q _{min}  [l/min (gal./min)]	1 (0.26)	1 (0.26)	1 (0.26)	1 (0.26)







ED = ciclo de trabalho

	Tubo curvado MIG/MAG 700i W ML
I (ampère) 10 min/ 40 °C M21+C1 (EN 439)	100 % ED* 700
 [mm (in.)]	1,0-1,6 (0.039-0.063)

	Tubo curvado MIG/MAG 700i W ML
Q _{min}  [l/min (gal./min)]	1 (0.26)

ED = ciclo de trabalho







Jogo de mangueira refrigerado a água - MHP 500d, 700d W ML

	MHP 500d W ML	MHP 700d W ML
I (ampère) 10 min/40 °C CO ²	100% CT* 500	100% CT* 700
I (ampère) 10 min/40 °C M21	100% CT* 400	100% CT* 560
 [mm (in.)]	0,8-1,6 (.032-.063)	0,8-1,6 (.032-.063)
 [m (ft.)]	3,35 / 4,35 (11 / 14)	3,35 / 4,35 (11 / 14)
P _{min}  [W]**	1400 / 1700	1800 / 2200
Q _{min}  [l/min (gal./min.)]	1 (.26)	1 (.26)
P _{min}  [bar (psi.)]	3 (43)	3 (43)
P _{max}  [bar (psi.)]	5 (72)	5 (72)

* CT = ciclo de trabalho

** Menor capacidade de refrigeração conforme norma IEC 60974-2



Jogo de mangueira refrigerado a água - MHP 700d W ML M

	MHP 700d W ML M
I (ampère) 10 min/40 °C CO ²	100% CT* 700
I (ampère) 10 min/40 °C M21	100% CT* 560
 [mm (in.)]	0,8-1,6 (.032-.063)
 [m (ft.)]	1,35 / 2,35 / 3,35 (4.4 / 7.7 / 14)
P _{min}  [W]**	1100 / 1450 / 1800
Q _{min}  [l/min (gal./min.)]	1 (.26)
P _{min}  [bar (psi.)]	3 (43)
P _{max}  [bar (psi.)]	5 (72)

* CT = ciclo de trabalho

** Menor capacidade de refrigeração conforme norma IEC 60974-2



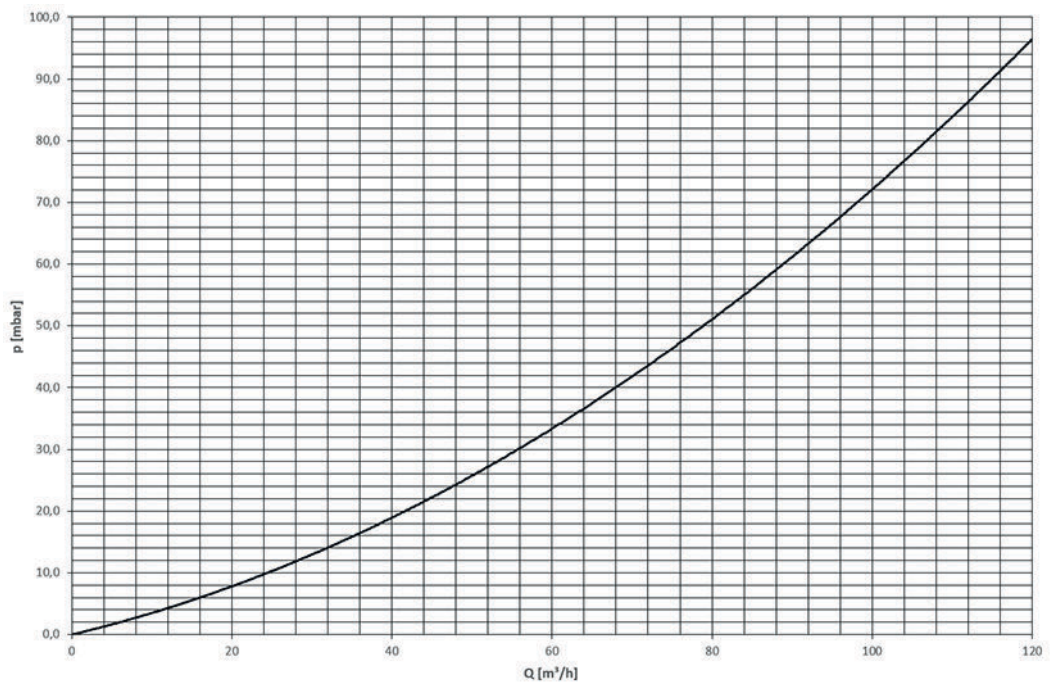

MTG 400d K4

		MTG 400d K4
I (ampère) 10 min/40 °C CO ₂ / misto		40% CT* 400 60% CT* 320 100% CT* 260
 [mm (in.)]		0,8-1,6 (.032-.063)
 [m (ft.)]		4,5 (15)

* CT = ciclo de trabalho

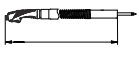
**Curva sinérgica
de sucção MTG
400d K4**

MTW 500d K4

		MTW 500d K4
I (ampère) 10 min/40 °C CO ₂ / misto		100 % CT* 500
 [mm (in.)]		0,8-1,6 (.032-.063)
 [m (ft.)]		4,5 (15)
P _{max}  [W]**		1700
Q _{min}  [l/min (gal./min)]		1 (26)
P _{min}  [bar (psi.)]		3 (43)
P _{max}  [bar (psi.)]		5 (72)

* CT = ciclo de trabalho

** Capacidade de refrigeração mínima conforme a norma IEC 60974-2

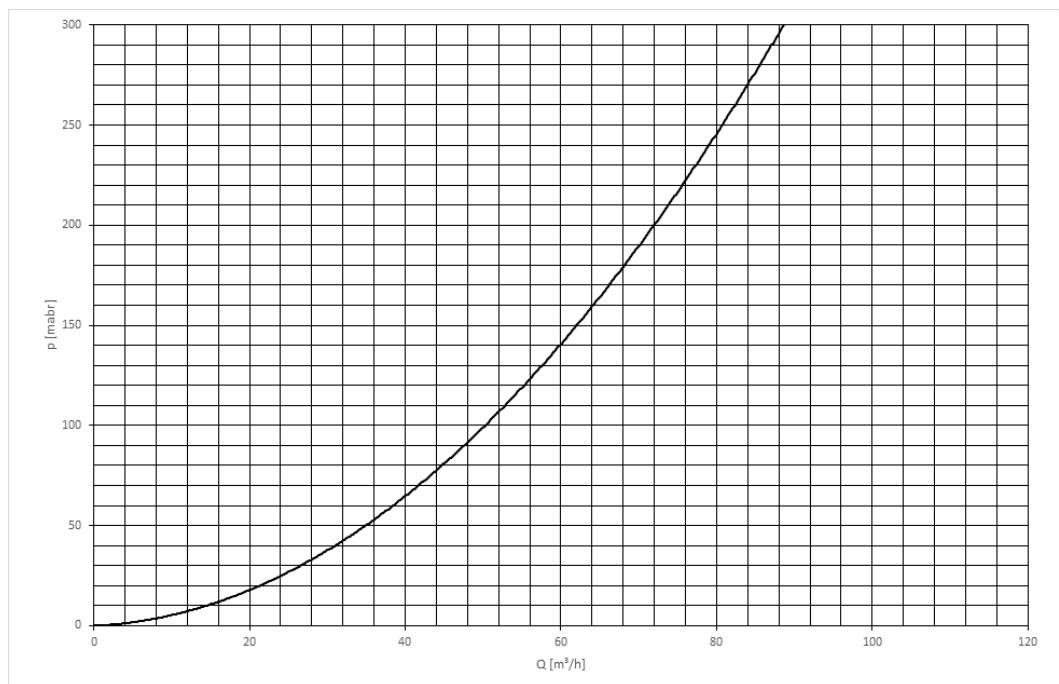
**Curva sinérgica
de sucção MTW
500d K4**



Fronius International GmbH

Froniusstraße 1
4643 Pettenbach
Austria
contact@fronius.com
www.fronius.com

At www.fronius.com/contact you will find the contact details
of all Fronius subsidiaries and Sales & Service Partners.