

L3009  
Rev. D 10/21

# Hydraulic Torque Wrench

W22000  
W35000

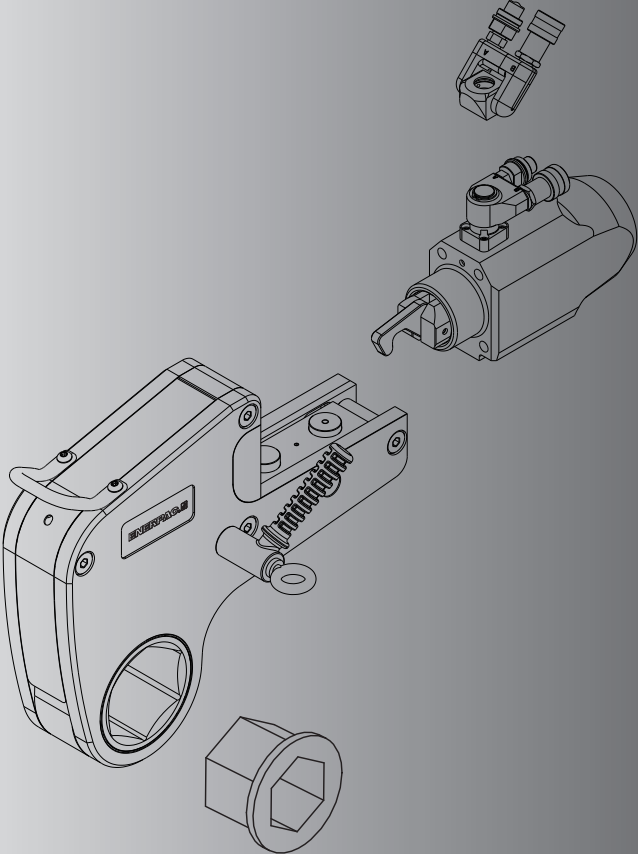

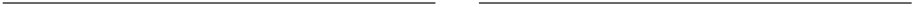

---

# Instruction Sheet

# Torque Wrench W22000 Series W35000 Series

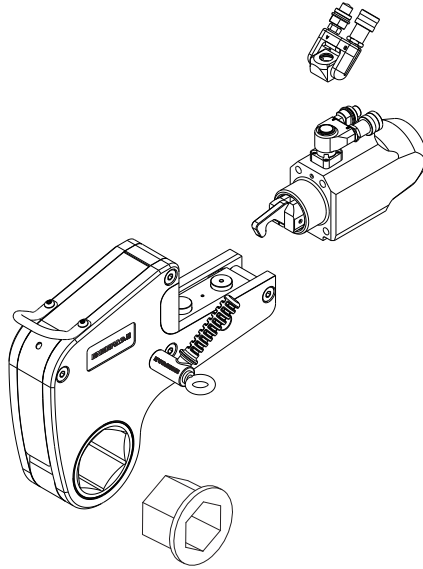

## Index

1	Introduction .....	4
2	Safety .....	4
3	Assembly and adjustments.....	6
4	Operation .....	8
5	Maintenance and troubleshooting .....	10
6	Technical specifications - W22000 Series.....	13
7	Technical specifications - W35000 Series.....	19
8	Replacement parts and recommended tools .....	24

---

# 1 Introduction

## Overview

The Enerpac W-Series hydraulic torque wrench is designed for controlled tightening and loosening of fasteners in industrial bolting applications. Its low profile cassette, compact drive unit and integrated reaction foot make the W-Series ideal for use in locations where workspace is limited.

Interchangeable W-Series cassettes are available in a large assortment of both metric and imperial sizes to suit specific customer requirements.

An optional TSP-Pro Series Swivel provides 360 degree X-axis and 160 degree Y-axis rotation, allowing easier positioning of the wrench and hoses in confined areas.

The W-Series can be used with a wide range of Enerpac bolting pumps. Electric, air and hand style models are available.

## Delivery instructions

Upon delivery all components must be inspected for damage incurred during shipping. If damage is found the carrier should be notified at once. Shipping damage is not covered by the Enerpac warranty.

## Warranty

- Enerpac guarantees the product only for the purpose for which is intended.
- All Enerpac products are guaranteed against defects in workmanship and materials for as long as you own them.

Any misuse or alteration invalidates the warranty.

- Observe all instructions as communicated in this manual.
- Replace any parts with Enerpac spare parts only.

---

## Conformance to National and International Standards



Enerpac declares that the product(s) have been tested and conforms to applicable standards and the product(s) are compatible to all EU and UK Requirements.

Copies of the EU Declaration as well as the UK Self-Declaration are enclosed with each shipment.

## 2 Safety

Be aware that the operator is fully responsible during the operation of this tool. Enerpac is not responsible for damage or injury caused by misuse of this tool. Under some circumstances, additional safety precautions beyond those described in this manual may be required. Contact Enerpac immediately if a potentially hazardous situation arises.



Read this manual carefully and observe all safety precautions.

- Make sure you have completed safety induction training, specific to the work surroundings. The operator should be thoroughly familiar with the controls and the proper use of the tool.
- The operator must be at least 18 years of age.
- Always wear protective headwear, ear protectors, footwear and gloves (at a minimum rigger type gloves) suitable for safe operation of the tool. The protective clothing must not interfere with safe operation of the tool or restrict the ability to communicate with co-workers.
- Make sure your workplace is safe.
- Do not place any part of the body between the reaction foot and the reaction point.

- 
- Do not place any objects between the reaction foot and the reaction point. Keep the hoses away from the reaction points.
  - Do not stand in the line of movement of the tool when it is in operation. If the tool separates from the nut or bolt during operation it will detach in that direction.
  - Tightening and loosening nuts and bolts involves little visible movement. The pressure and loads, however are extreme. Keep your hands away from the fastener being loosened or tightened.
  - Make sure that the spanner used to keep the nut or bolt on the opposite end is secured.
  - Always use Enerpac pumps and hoses.
  - Make sure appropriate guards are always securely in position and free from damage.
  - Maximum pressure is 690 bar (10,000 psi). Never apply more pressure to any tool or accessory than the maximum allowable pressure. Refer to the technical data tables for maximum pressure setting.
  - Make sure that the ratchet size corresponds to the size of the fastener being loosened or tightened. Failure to do so can result in the tool becoming unstable and can lead to catastrophic failure of the tool.
  - Do not abuse or overstress the hoses in any way. Do not bend the hoses excessively.
  - Never carry the tool by its hoses.
  - Always use Enerpac spare parts.
  - Always position the tool for maximum stability. Make sure reaction points are adequate for the forces at work during operation of the tool.
  - Be aware that a nut or bolt that breaks off during operation of the tool will become a high velocity projectile.
  - Make sure the reaction point is of a suitable shape. For example use an adjacent nut or bolt as a reaction point.
  - When the hex ratchet is placed on the nut or bolt a gap may exist between the reaction foot and the reaction plate. When the tool is operated the reaction foot and point will make forceful contact. Always make sure the tool is stable.
  - Provide adequate support in vertical and inverted applications.
  - The maximum torque output of the tool must always exceed the torque required to loosen or tighten the nut or bolt.
  - The torque required to loosen a nut is variable and may exceed the torque capacity of the tool. Never operate the tool at above 75 percent of tool maximum torque when loosening a nut or bolt (see section 4.3.2).
  - Never operate the tool with a hydraulic supply connection to the advance side only as this may damage the internal parts.
  - If the wrench is dropped from a height, have the tool inspected before you operate it again.
  - In severe conditions the tool must be cleaned and lubricated more frequently (see section 5).
  - Check that the swivel post screws (see 5.2.1) and gland are tight prior to use.
  - If oil leakage is evident, replace seals accordingly (see section 5).
  - Stop operation immediately if a gap appears between the cylinder locating plate and the drive unit. Have the tool inspected and serviced before you operate it again.
  - Make sure to minimize torsional and bending stresses in the tool, the hex ratchet and any accessories.
  - Do not strike the tool with a hammer while under a full load. This will invalidate the product warranty.
  - Always observe the maintenance instructions.
-

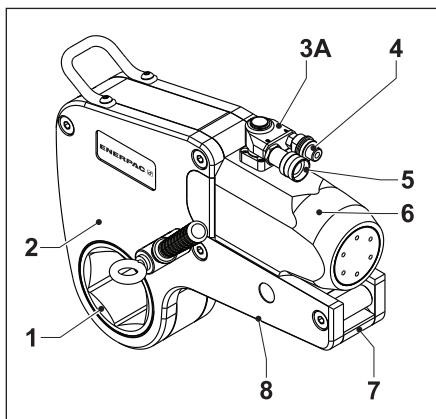

Fig. A

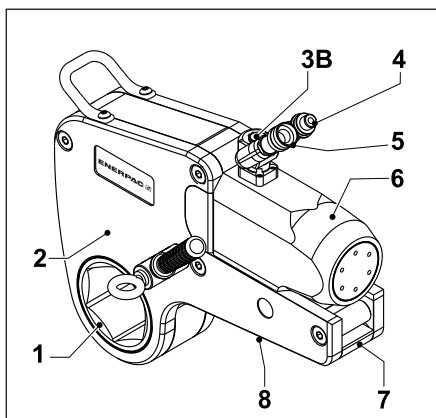

Fig. B

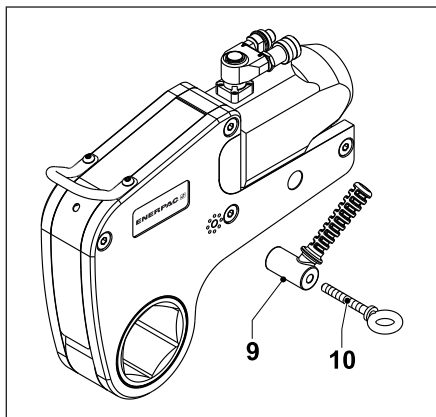

Fig. C

### 3 Assembly and adjustments

#### 3.1 Overview and features (fig. A or B)

- 1 Hexagon ratchet
- 2 Cassette
- 3A Swivel coupling or
- 3B TSP-Pro swivel coupling (optional)
- 4 Advance hose connection
- 5 Return hose connection
- 6 Hydraulic drive unit
- 7 Cassette release lever
- 8 Reaction foot

#### 3.2 To attach the positioning handle (fig. C)

- Secure the positioning handle (9) with eye-bolt (10). Tighten hand tight.

#### 3.3 Changing the cassette

 Make sure to depressurize and disconnect the tool from the hydraulic supply first.

##### 3.3.1 To remove cassette (fig. D & E)

- Make sure the piston is fully retracted.
- Place the tool on a workbench or support it using a hoist.

 Hydraulic drive unit will disengage from cassette in the following steps. Be sure that cassette is supported so it does not drop.

- Pull the cassette release lever (7) outwards.
- Remove the hydraulic drive unit (6) from the cassette (2).

##### 3.3.2 To attach cassette (fig. D & E)

- Make sure the retract link (11) aligns with the slot (13) in the crank. Rotate the piston rod if necessary.
- Pull the release lever (7) outwards.
- Push the spigot (12) into the cylinder locating plate (14).

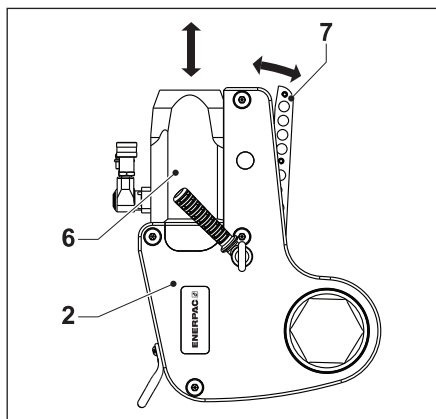

Fig. D

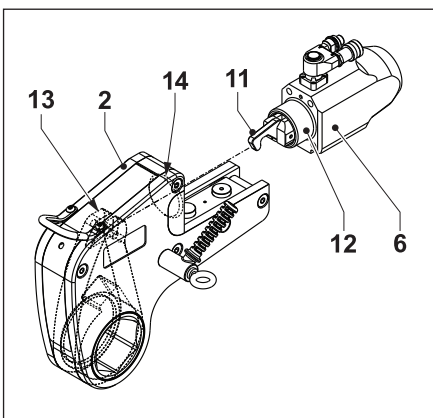

Fig. E

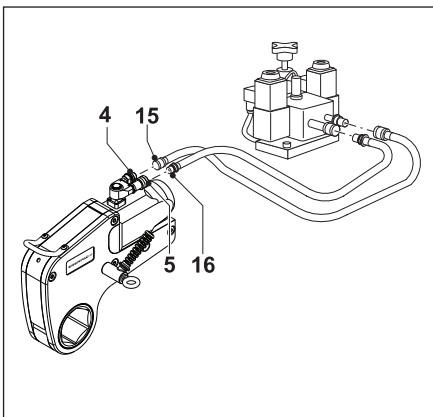

Fig. F

- Push the release lever (7) back into the cassette (2). Make sure the ball detent clicks into place.



Do not operate the tool if the cassette release lever is not fully closed.

### 3.4 To connect the hoses (fig. F)



Make sure all accessories meet the pressure requirements. Make sure the quick connect couplings are securely attached before operating the tool.

The tool is fitted with male and female quick-connect couplings. Use Enerpac twin safety hoses only. Refer to the table below:

Enerpac hose model number	Description
THQ-706T	Two hoses, 6 m (19.5 feet) long
THQ-712T	Two hoses, 12 m (39 feet) long

- Remove the hose dust caps.
- Connect the hose with the female coupling (15) to the advance coupling (4).
- Pull the sleeve on the female coupling of the hose over the advance coupling.
- Tighten the sleeve.
- Connect the hose with the male coupling (16) into the return coupling (5).
- Pull the sleeve on the return coupling over the male coupling of the hose.
- Tighten the sleeve.
- Fit the hoses to the pump. Refer to the pump instruction manual.

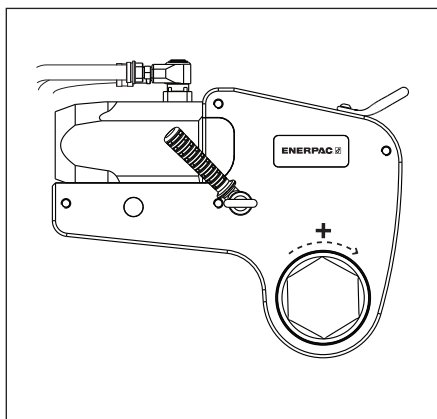

Fig. G

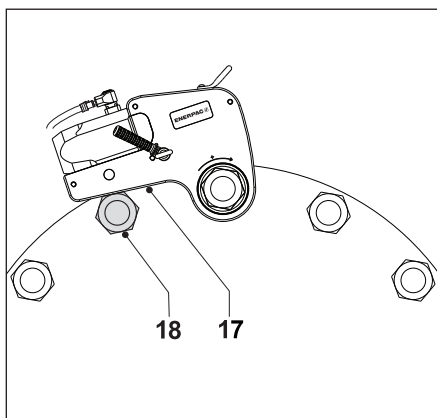

Fig. H

## 4 Operation

### 4.1 Prior to operation

- Make sure the nut or bolt to be fastened is clean and free of dust.
- Make sure the nut or bolt runs correctly on the thread.
- Make sure that the threads and the bearing surface are liberally coated with the correct lubricant or anti-seizure compound.
- Make sure that the spanner used to keep the nut or bolt on the opposite end in place, is of the correct size and that there is an adequate abutment surface. Ensure that the spanner is secured.
- Contact Enerpac if a suitable reaction point is not available.

### 4.2 To set the torque

Adjust the pressure on the pump as necessary to set the torque.

#### 4.3.1 To tighten a nut or bolt (fig. G & H)

- Position the tool on the nut or bolt with the clockwise (+) side facing upwards.
- Position the reaction foot (17) against a suitable reaction point (18). The reaction point will counteract the force caused by operating the tool.
- Start the pump.
- Operate the pump until the nut or bolt has been tightened to the required torque.
- Stop the pump immediately after work has finished.

 Stop operation immediately if a gap appears between the cylinder locating plate and the drive unit.

 Do not strike the tool with a hammer while under a full load.



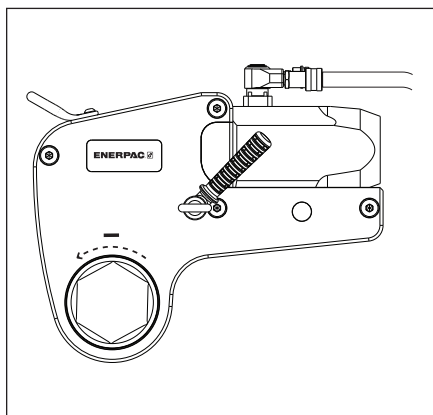

Fig. I

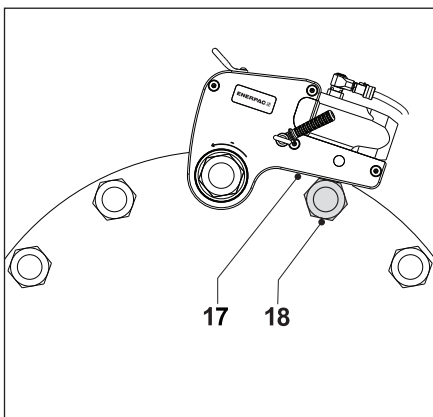

Fig. J

#### 4.3.2 To loosen a nut or bolt (fig. I & J)

- Apply penetrating oil to the threads. Allow the oil to soak.
- Position the tool on the nut or bolt with the anti-clockwise (-) side facing upwards.
- Position the reaction foot (17) against a suitable reaction point (18). The reaction point will counteract the force caused by operating the tool.
- Start the pump.
- Operate pump until nut (bolt) is loose.



If the nut or bolt will be re-used avoid excess load when loosening.

- Be aware that when loosening a nut or bolt more torque is usually required than when tightening.
- Humidity corrosion (rust) requires up to twice the torque required for tightening.
- Sea water and chemical corrosion requires up to two and a half times the torque required for tightening.
- Heat corrosion requires up to three times the torque required for tightening.



Be aware that when loosening a nut or bolt shock loading can occur. Do not apply more than 75% of the wrench's maximum torque when loosening nuts or bolts.

## 5 Maintenance and troubleshooting



Preventative maintenance can be carried out by the user. Full maintenance must be carried out by an approved and authorized technician appointed by Enerpac. Recommended service intervals are:

- a) 3 months – Heavy Duty use
- b) 6 months – Normal use
- c) 12 months – Infrequent use

- Non destructive testing must be carried out if the tool has been used under severe conditions.

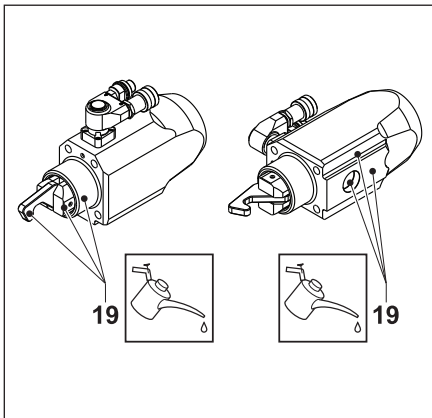

Fig. K

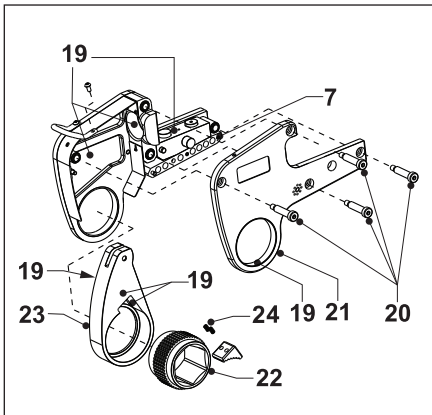

Fig. L

### 5.1 Preventative maintenance (fig. K & L)

#### 5.1.1 The hydraulic drive unit

- Check tightness of swivel post retaining screws (see 5.2.1) and gland.
- Pressurize the drive unit to maximum pressure (Advance and Retract), and check for any signs of leakage.
- Any damaged components or seals must be replaced.
- Dry all components and apply a thin coat of molybdenum disulphide as indicated (19).



Molybdenum disulphide is available from Enerpac.

#### 5.1.2 The cassette

- Remove the cassette from the drive unit.
- Remove the screws (20). Lift and remove the sideplates (21).
- Remove the hex ratchet (22), spring loaded drive shoe (23), and compression springs (24).
- Clean all exposed components with a mild solvent.
- Inspect all parts for damage.
- Dry all components. Apply a thin coat of molybdenum disulphide as indicated (19).



Do not apply any lubricant to the ratchet or drive shoe teeth.

---

## 5.2 Full maintenance

### 5.2.1 The hydraulic drive unit

- Remove the circlip from the swivel coupling.
- Remove the couplings.
- Remove the swivel-coupling block from the drive unit.
- Remove the swivel post by removing the swivel post retaining screws.
- Remove all 'O' rings from the swivel post.
- Carefully hold the cylinder body to unscrew the cylinder gland.
- Hold the two flat sides of the piston rod with a spanner. The rod is located at the spigot.
- Remove the button head cap screw from the piston.
- Remove the piston rod from the cylinder spigot end.
- Remove the piston from the cylinder gland end, using a suitable drift.
- Clean all exposed components with a mild solvent.
- Inspect all parts for damage.
- Carry out non destructive testing by magnetic particle inspection on the following components:
  - Cylinder
  - Piston rod
- Apply a small amount of Loctite 243 to the threads of the piston retaining screw before reassembly.
- Apply a small amount of Loctite 243 to the threaded holes in the drive unit. Assemble the swivel post and tighten the degreased swivel post retaining screws (M5 screws) to 10,2 Nm.

- 
- Reverse the procedure to reassemble
  - Pressurize the assembled drive unit to max pressure (Advance and Retract), and check for any signs of leakage.



When reassembling the drive unit make sure that the piston rod is inserted through the cylinder spigot end.

When reassembling the drive unit make sure that the piston is inserted through the gland end. Tap the piston gently into place against the piston rod.

### 5.2.2 The cassette

- Strip down and clean all exposed components with a mild solvent.
- Drift out the roll pin holding the cylinder retaining pin, and remove.
- Inspect all parts for damage.
- Carry out non destructive testing by magnetic particle inspection on the following components:
  - Sideplates
  - Locating plate
  - Pin retainer
  - Reaction foot
  - Crank
  - Ratchet
  - Drive shoe
  - Cylinder retaining pin
  - Spacer retaining pin
- Dry all components. Apply a thin coat of molybdenum disulphide as indicated (19).

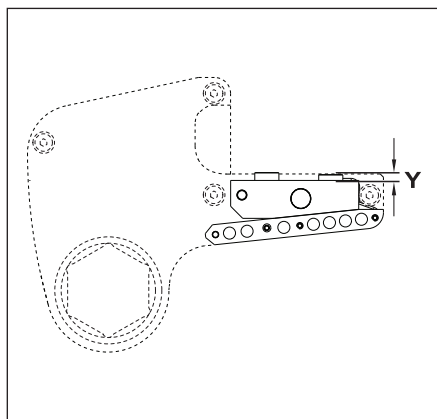

Fig. M

- As a check, refer to figure M and the tables below for the correct height of the fail safe pin (Y).

#### Fail Safe Pin Height - W22000 Series

(fig. M, dimension "Y")	
Metric	Imperial
7,5 mm	0.296 inch

#### Fail Safe Pin Height - W35000 Series

(fig. M, dimension "Y")	
Metric	Imperial
7,0 mm	0.276 inch

- Reverse the procedure to reassemble the tool.

## 5.3 Troubleshooting

### 5.3.1 Drive Unit

Symptom	Cause	Remedy
Cylinder does not advance or retract	Quick-connect coupling is damaged	Replace the coupling
	Quick-connect coupling is not connected	Reconnect the hoses and couplings securely
	Dirt in the direction control valve on the pumping unit	Disassemble the unit and clean the valve
Cylinder does not build up pressure	Piston seal leaks	Replace the seals
	Pump does not build pressure	Adjust the pressure
	Pump is defective	Refer to the pump manual
Cylinder leaks	Seal failure	Replace the cylinder seals
Cylinder operates backwards	Connections are reversed	Reconnect the hoses

### 5.3.2 Cassette

Symptom	Cause	Remedy
Ratchet returns on retract stroke	Broken drive shoe	Replace the drive shoe
Ratchet does not take successive strokes	Defective drive shoe	Replace the drive shoe
	Lubricant on the ratchet and/or drive shoe splines	Disassemble the cassette and remove the lubricant from splines

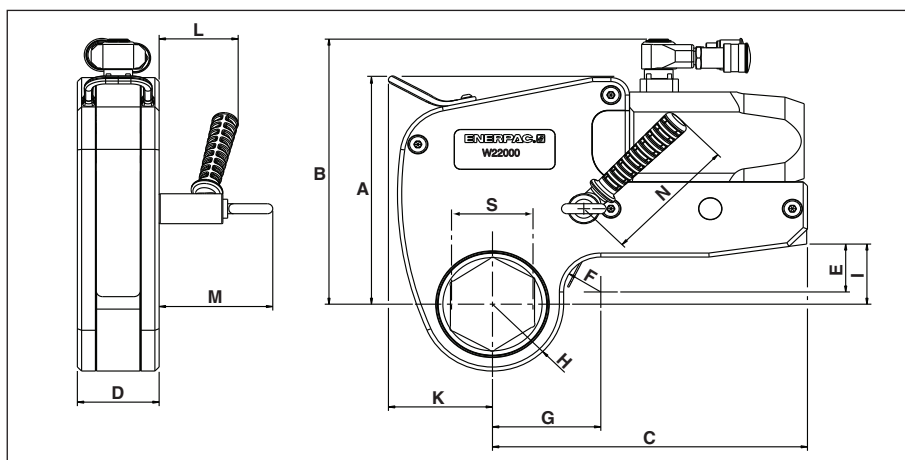

Fig. N

## 6 Technical specifications - W22000 Series

### 6.1 W22000 Series - Capacities and dimensions (fig. N)

Hexagon size range of available cassettes*	mm	75 - 135
	inch	2 15/16 - 5 3/8
Maximum operating pressure	bar	690
	psi	10,000
Max. torque	at 690 bar	Nm 30.506
	at 10,000 psi	Ft.lbs 22,500
Min. torque	Nm	3.051
	Ft.lbs	2,250
Dimensions	A	mm (inch) 227,2 (8.94)
	B	mm (inch) 265,7 (10.46)
	C	mm (inch) 296,6 (11.68)
	D	mm (inch) 77,0 (3.03)
	E	mm (inch) 48,0 (1.89)
	F	mm (inch) 35,0 (1.38)
	G	- - - (see Section 6.2)
	H	- - - (see Section 6.2)
	I	mm (inch) 60,3 (2.37)
	K	mm (inch) 98,0 (3.86)
	L	mm (inch) 74,4 (2.93)
	M	mm (inch) 107,0 (4.21)
	N	mm (inch) 127,6 (5.02)
S	- - - (see Section 6.2)	
Weight of Drive Unit	kg (lbs)	7,7 (16.98)

\* **Important:** Hexagon reducer inserts (if used) must meet minimum wall thickness requirements. Refer to Section 6.2 for additional information. Consult your Enerpac distributor regarding the availability of inserts for your cassette model.

## 6.2 Additional cassette specifications - W22000 Series

### 6.2.1 Metric system table (See fig. N for dimensions S, G and H)

Cassette Model	(S) Hex Size mm	(G) mm	(H) mm	Weight kg
W22215	75	102	67,0	22,1
W22300	77	102	67,0	22,0
W22301	78	102	67,0	21,9
W22302	80	102	67,0	21,7
W22303	81	107,5	72,5	22,9
W22304	83	107,5	72,5	22,8
W22305	84	107,5	72,5	22,6
W22085M	85	107,5	72,5	22,6
W22306	86	107,5	72,5	22,5
W22308	89	107,5	72,5	22,2
W22090M	90	113	78	23,5
W22309	91	113	78	23,4
W22310	92	113	78	23,3
W22311	94	113	78	23,1
W22312	95	113	78	23,1
W22313	97	113	78	22,8
W22314	99	113	78	22,6
W22315	100	120	85	24,3
W22400	102	120	85	24,1
W22402	105	120	85	23,8
W22404	108	120	85	23,4
W22405	110	125	90	24,6
W22406	111	125	90	24,5
W22407	113	125	90	24,3
W22115M	115	125	90	24,1
W22412	120	130	95	24,7
W22123M	123	130	95	24,4
W22414	124	130	95	24,3
W22500	127	130	95	23,8
W22502	130	135	100	25,0
W22506	135	135	100	23,9

Cassette Model	Required minimum wall thickness of hexagon reducer insert:
W22205 - W22404	9,2 mm
W22405 - W22506	7,75 mm

**Important:** If wall thickness is less than shown in the table above, the insert may experience reduced component life. Consult your Enerpac distributor regarding the availability of inserts for your cassette model.

### 6.2.2 Imperial system table (See fig. N for dimensions S, G and H)

Cassette Model	(S) Hex Size inch	(G) inch	(H) inch	Weight lbs
W22215	2 <sup>15</sup> / <sub>16</sub>	4.02	2.64	48.7
W22300	3	4.02	2.64	48.4
W22301	3 <sup>1</sup> / <sub>16</sub>	4.02	2.64	48.2
W22302	3 <sup>1</sup> / <sub>8</sub>	4.02	2.64	47.8
W22303	3 <sup>3</sup> / <sub>16</sub>	4.23	2.85	50.6
W22304	3 <sup>1</sup> / <sub>4</sub>	4.23	2.85	50.2
W22305	3 <sup>5</sup> / <sub>16</sub>	4.23	2.85	49.9
W22306	3 <sup>3</sup> / <sub>8</sub>	4.23	2.85	49.7
W22307	3 <sup>7</sup> / <sub>16</sub>	4.23	2.85	50.3
W22308	3 <sup>1</sup> / <sub>2</sub>	4.23	2.85	48.9
W22309	3 <sup>9</sup> / <sub>16</sub>	4.45	3.07	51.6
W22310	3 <sup>5</sup> / <sub>8</sub>	4.45	3.07	51.3
W22311	3 <sup>11</sup> / <sub>16</sub>	4.45	3.07	50.9
W22312	3 <sup>3</sup> / <sub>4</sub>	4.45	3.07	50.6
W22313	3 <sup>13</sup> / <sub>16</sub>	4.45	3.07	50.2
W22314	3 <sup>7</sup> / <sub>8</sub>	4.45	3.07	49.8
W22315	3 <sup>15</sup> / <sub>16</sub>	4.72	3.35	53.6
W22400	4	4.72	3.35	53.2
W22401	4 <sup>1</sup> / <sub>16</sub>	4.72	3.35	52.8
W22402	4 <sup>1</sup> / <sub>8</sub>	4.72	3.35	52.4
W22403	4 <sup>3</sup> / <sub>16</sub>	4.72	3.35	52.1
W22404	4 <sup>1</sup> / <sub>4</sub>	4.72	3.35	51.5
W22405	4 <sup>5</sup> / <sub>16</sub>	4.92	3.54	54.3
W22406	4 <sup>3</sup> / <sub>8</sub>	4.92	3.54	53.9
W22407	4 <sup>7</sup> / <sub>8</sub>	4.92	3.54	53.5
W22408	4 <sup>1</sup> / <sub>2</sub>	4.92	3.54	53.1
W22409	4 <sup>9</sup> / <sub>16</sub>	4.92	3.54	52.6
W22410	4 <sup>5</sup> / <sub>8</sub>	4.92	3.54	52.0
W22412	4 <sup>3</sup> / <sub>4</sub>	5.12	3.74	54.5
W22414	4 <sup>7</sup> / <sub>8</sub>	5.12	3.74	53.6
W22500	5	5.12	3.74	52.4
W22502	5 <sup>1</sup> / <sub>8</sub>	5.31	3.94	55.1
W22503	5 <sup>3</sup> / <sub>16</sub>	5.31	3.94	54.7
W22504	5 <sup>1</sup> / <sub>4</sub>	5.31	3.94	54.1
W22506	5 <sup>3</sup> / <sub>8</sub>	5.31	3.94	52.8

Cassette Model	Required minimum wall thickness of hexagon reducer insert:
W22205 - W22404	0.36 inch
W22405 - W22506	0.31 inch

**Important:** If wall thickness is less than shown in the table above, the insert may experience reduced component life. Consult your Enerpac distributor regarding the availability of inserts for your cassette model.

### 6.3 Torque settings - W22000 Series

#### 6.3.1 Metric system pressure/torque table - W22000 Series

Pump pressure (bar)	Torque (Nm)	Pump pressure (bar)	Torque (Nm)
69	3.051	386	17,068
83	3.670	400	17,687
97	3.670	414	18,306
110	4.864	428	18,925
124	5.483	441	19,500
138	6.102	455	20,119
152	6.721	469	20,738
166	7.340	483	21,357
179	7.915	497	21,976
193	8.534	510	22,551
207	9.153	524	23,170
221	9.772	538	23,789
234	10.347	552	24,408
248	10.966	566	25,027
262	11.585	579	25,602
276	12.204	593	26,221
290	12.823	607	26,840
303	13.398	621	27,459
317	14.017	634	28,034
331	14.636	648	28,653
345	15.255	662	29,272
359	15.874	676	29,891
372	16.449	690	30,510

To set the torque, adjust the pump pressure according to the following calculation:

$$\text{Pump pressure} = \text{Desired Torque} \div \text{Torque Factor}$$

Torque Factor (metric system)	
W22000 Series	44,217



### 6.3.2 Imperial system pressure/torque table - W22000 Series

Pump pressure (psi)	Torque (Ft.lbs)	Pump pressure (psi)	Torque (Ft.lbs)
1,000	2,250	5,600	12,600
1,200	2,700	5,800	13,050
1,400	3,150	6,000	13,500
1,600	3,600	6,200	13,950
1,800	4,050	6,400	14,400
2,000	4,500	6,600	14,850
2,200	4,950	6,800	15,300
2,400	5,400	7,000	15,750
2,600	5,850	7,200	16,200
2,800	6,300	7,400	16,650
3,000	6,750	7,600	17,100
3,200	7,200	7,800	17,550
3,400	7,650	8,000	18,000
3,600	8,100	8,200	18,450
3,800	8,550	8,400	18,900
4,000	9,000	8,600	19,350
4,200	9,450	8,800	19,800
4,400	9,900	9,000	20,250
4,600	10,350	9,200	20,700
4,800	10,800	9,400	21,150
5,000	11,250	9,600	21,600
5,200	11,700	9,800	22,050
5,400	12,150	10,000	22,500

To set the torque, adjust the pump pressure according to the following calculation:

$$\text{Pump pressure} = \text{Desired torque} \div \text{Torque Factor}$$

Torque Factor (imperial system)	
W22000 Series	2.25

---

NOTES:

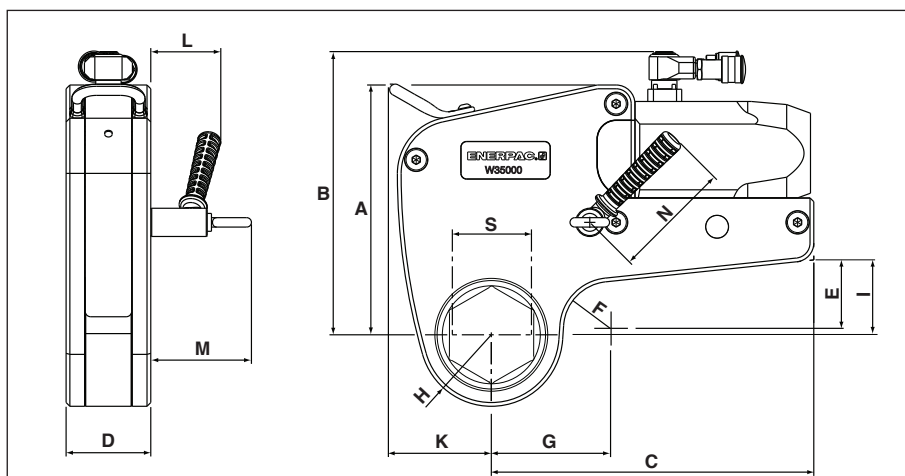



Fig. O

## 7 Technical specifications - W35000 Series

### 7.1 W35000 Series - Capacities and dimensions (fig. O)

Hexagon size range of available cassettes*	mm	80 - 155	
	inch	3 1/8 - 6 1/8	
Maximum operating pressure	bar	690	
	psi	10,000	
Max. torque	at 690 bar	Nm 47.453	
	at 10,000 psi	Ft.lbs 35,000	
Min. torque	Nm	4.745	
	Ft.lbs	3,500	
Dimensions	A	mm (inch)	268 (10.54)
	B	mm (inch)	303 (11.94)
	C	mm (inch)	345 (13.60)
	D	mm (inch)	91 (3.57)
	E	---	(see Section 7.2)
	F	mm (inch)	50 (1.98)
	G	---	(see Section 7.2)
	H	---	(see Section 7.2)
	I	mm (inch)	79,5 (3.13)
	K	mm (inch)	108 (4.2)
	L	mm (inch)	74,4 (2.93)
	M	mm (inch)	107 (4.21)
	N	mm (inch)	127 (5.00)
S	---	(see Section 7.2)	
Weight of Drive Unit	kg (lbs)	12 (26.4)	

\* **Important:** Hexagon reducer inserts (if used) must meet minimum wall thickness requirements. Refer to Section 7.2 for additional information. Consult your Enerpac distributor regarding the availability of inserts for your cassette model.

## 7.2 Additional cassette specifications - W35000 Series

### 7.2.1 Metric system table (See fig. O for dimensions S, E, G and H)

Cassette Model	(S) Hex Size mm	(E) mm	(G) mm	(H) mm	Weight kg
W35302	80	73,0	126,75	76,0	32,8
W35303	81	73,0	126,75	76,0	32,7
W35304	83	73,0	126,75	76,0	32,5
W35305	84	73,0	126,75	76,0	32,4
W35085M	85	73,0	126,75	76,0	32,3
W35306	86	73,0	126,75	76,0	32,2
W35308	89	73,0	126,75	76,0	32,0
W35090M	90	72,4	132,5	81,5	33,5
W35309	91	72,4	132,5	81,5	33,4
W35310	92	72,4	132,5	81,5	33,3
W35311	94	72,4	132,5	81,5	33,1
W35312	95	72,4	132,5	81,5	32,9
W35313	97	72,4	132,5	81,5	32,7
W35314	99	72,4	132,5	81,5	32,4
W35315	100	71,9	137,0	87,0	34,1
W35400	102	71,9	137,0	87,0	33,9
W35402	105	71,9	137,0	87,0	33,5
W35404	108	71,9	137,0	87,0	33,0
W35405	110	71,3	143,0	93,0	34,9
W35406	111	71,3	143,0	93,0	34,7
W35407	113	71,3	143,0	93,0	34,5
W35115M	115	71,3	143,0	93,0	34,2
W35412	120	70,7	148,5	98,5	35,6
W35123M	123	70,7	148,5	98,5	35,0
W35414	124	70,7	148,5	98,5	34,9
W35500	127	70,7	148,5	98,5	34,3
W35502	130	70,2	153,0	103,0	35,8
W35506	135	70,2	153,0	103,0	34,6
W35508	140	69,6	158,5	108,5	36,2
W35509	141	69,6	158,5	108,5	36,0
W35510	143	69,6	158,5	108,5	35,6
W35512	145	69,6	158,5	108,5	34,9
W35514	150	69,1	164,0	114,0	36,7
W35151M	151	69,1	164,0	114,0	36,5
W35600	153	69,1	164,0	114,0	36,1
W35602	155	69,1	164,0	114,0	35,3

Cassette Model	Required minimum wall thickness of hexagon reducer insert:
W35302 - 35404	14,50 mm
W35405 - 35602	12,00 mm

**Important:** If wall thickness is less than shown in the table above, the insert may experience reduced component life. Consult your Enerpac distributor regarding the availability of inserts for your cassette model.

7.2.2 Imperial system table (See fig. O for dimensions S, E, G and H)

Cassette Model	(S) Hex Size inch	(E) inch	(G) inch	(H) inch	Weight lbs
W35302	3 1/8	2.87	4.99	2.99	72.3
W35303	3 3/16	2.87	4.99	2.99	72.1
W35304	3 1/4	2.87	4.99	2.99	71.7
W35305	3 5/16	2.87	4.99	2.99	71.4
W35306	3 3/8	2.87	4.99	2.99	71.0
W35307	3 7/16	2.87	4.99	2.99	70.5
W35308	3 1/2	2.87	4.99	2.99	70.1
W35309	3 9/16	2.85	5.22	3.21	71.4
W35310	3 5/8	2.85	5.22	3.21	73.4
W35311	3 11/16	2.85	5.22	3.21	73.0
W35312	3 3/4	2.85	5.22	3.21	72.5
W35313	3 13/16	2.85	5.22	3.21	72.1
W35314	3 7/8	2.85	5.22	3.21	71.4
W35315	3 15/16	2.83	5.39	3.42	70.8
W35400	4	2.83	5.39	3.42	74.7
W35401	4 1/16	2.83	5.39	3.42	74.3
W35402	4 1/8	2.83	5.39	3.42	73.9
W35403	4 3/16	2.83	5.39	3.42	73.4
W35404	4 1/4	2.83	5.39	3.42	72.8
W35405	4 5/16	2.81	5.63	3.66	76.9
W35406	4 3/8	2.81	5.63	3.66	76.5
W35407	4 7/16	2.81	5.63	3.66	76.1
W35408	4 1/2	2.81	5.63	3.66	75.6
W35409	4 9/16	2.81	5.63	3.66	75.2
W35410	4 5/8	2.81	5.63	3.66	74.5
W35412	4 3/4	2.78	5.85	3.88	78.5
W35414	4 7/8	2.78	5.85	3.88	76.9
W35500	5	2.78	5.85	3.88	75.6
W35502	5 1/8	2.76	6.02	4.05	78.9
W35503	5 3/16	2.76	6.02	4.05	78.5
W35504	5 1/4	2.76	6.02	4.05	77.6
W35506	5 3/8	2.76	6.02	4.05	76.3
W35508	5 1/2	2.74	6.24	4.27	79.8
W35509	5 9/16	2.74	6.24	4.27	79.4
W35510	5 5/8	2.74	6.24	4.27	78.5
W35512	5 3/4	2.74	6.24	4.27	76.9
W35514	5 7/8	2.72	6.46	4.49	80.9
W35600	6	2.72	6.46	4.49	79.6
W35602	6 1/8	2.72	6.46	4.49	77.8

Cassette Model	Required minimum wall thickness of hexagon reducer insert:
W35302 - 35404	0.57 inch
W35405 - 35602	0.48 inch

**Important:** If wall thickness is less than shown in the table above, the insert may experience reduced component life. Consult your Enerpac distributor regarding the availability of inserts for your cassette model.

---

### 7.3 Torque settings - W35000 Series

#### 7.3.1 Metric system pressure/torque table - W35000 Series

Pump pressure (bar)	Torque (Nm)	Pump pressure (bar)	Torque (Nm)
69	4.745	386	26.546
83	5.708	400	27.509
97	6.671	414	28.472
110	7.565	428	29.434
124	8.528	441	30.328
138	9.491	455	31.291
152	10.453	469	32.254
166	11.416	483	33.217
179	12.310	497	34.180
193	13.273	510	35.074
207	14.236	524	36.037
221	15.199	538	36.999
234	16.093	552	37.962
248	17.055	566	38.925
262	18.018	579	39.819
276	18.981	593	40.782
290	19.944	607	41.745
303	20.838	621	42.707
317	21.801	634	43.601
331	22.764	648	44.564
345	23.726	662	45.527
359	24.689	676	46.490
372	25.583	690	47.453

To set the torque, adjust the pump pressure according to the following calculation:

$$\text{Pump pressure} = \text{Desired Torque} \div \text{Torque Factor}$$

Torque Factor (metric system)	
W35000 Series	68.772

### 7.3.2 Imperial system pressure/torque table - W35000 Series

Pump pressure (psi)	Torque (Ft.lbs)	Pump pressure (psi)	Torque (Ft.lbs)
1,000	3,500	5,600	19,600
1,200	4,200	5,800	20,300
1,400	4,900	6,000	21,000
1,600	5,600	6,200	21,700
1,800	6,300	6,400	22,400
2,000	7,000	6,600	23,100
2,200	7,700	6,800	23,800
2,400	8,400	7,000	24,500
2,600	9,100	7,200	25,200
2,800	9,800	7,400	25,900
3,000	10,500	7,600	26,600
3,200	11,200	7,800	27,300
3,400	11,900	8,000	28,000
3,600	12,600	8,200	28,700
3,800	13,300	8,400	29,400
4,000	14,000	8,600	30,100
4,200	14,700	8,800	30,800
4,400	15,400	9,000	31,500
4,600	16,100	9,200	32,200
4,800	16,800	9,400	32,900
5,000	17,500	9,600	33,600
5,200	18,200	9,800	34,300
5,400	18,900	10,000	35,000

To set the torque, adjust the pump pressure according to the following calculation:

$$\text{Pump pressure} = \text{Desired torque} \div \text{Torque Factor}$$

Torque Factor (imperial system)	
W35000 Series	3.5

---

## 8 Replacement parts and recommended tools

### 8.1 To order replacement parts

For replacement parts information, refer to the Enerpac repair parts sheet for your wrench model. Repair parts sheets are available on the internet at [www.enerpac.com](http://www.enerpac.com).

Have the following information ready when ordering replacement parts:

- Wrench model and serial numbers (for both drive unit and cassette).
- Approximate date of purchase.
- Part number and description of each part being ordered.

### 8.2 Recommended tool kit for W22000 Series

- 7/8" A/F spanner
- 3/4" A/F spanner
- 5/8" spanner
- Circlip pliers
- Seal extraction tool
- 1-11/16" A/F spanner
- ø 5 mm x 6 mm LG x 45 mm PCD pin spanner
- 10 mm A/F Allen key
- 6 mm A/F Allen key
- 4 mm A/F Allen key
- 2,5 mm A/F Allen key
- 3 mm Terminal screwdriver

**Notes:**

A/F = Across Flats

PCD = Pitch Circle Diameter

---

### 8.3 Recommended tool kit for W35000 Series

- 7/8" A/F spanner
- 3/4" A/F spanner
- 5/8" spanner
- Circlip pliers
- Seal extraction tool
- 2" A/F spanner
- ø 5 mm x 6 mm LG x 50 mm PCD pin spanner
- 10 mm A/F Allen key
- 8 mm A/F Allen key
- 4 mm A/F Allen key
- 2,5 mm A/F Allen key
- 3 mm Terminal screwdriver

**Notes:**

A/F = Across Flats

PCD = Pitch Circle Diameter



---

NOTES:

A large rectangular box containing 20 horizontal lines, intended for handwritten notes.

---

NOTES:

A large rectangular area with a vertical border on the left and right sides. Inside this area, there are 20 horizontal lines spaced evenly, providing a template for handwritten notes.

---

NOTES:

A large rectangular box containing 20 horizontal lines for writing notes.

---

**ENERPAC** 

[www.enerpac.com](http://www.enerpac.com)

---